

# E180 DIAMETER FRAMES

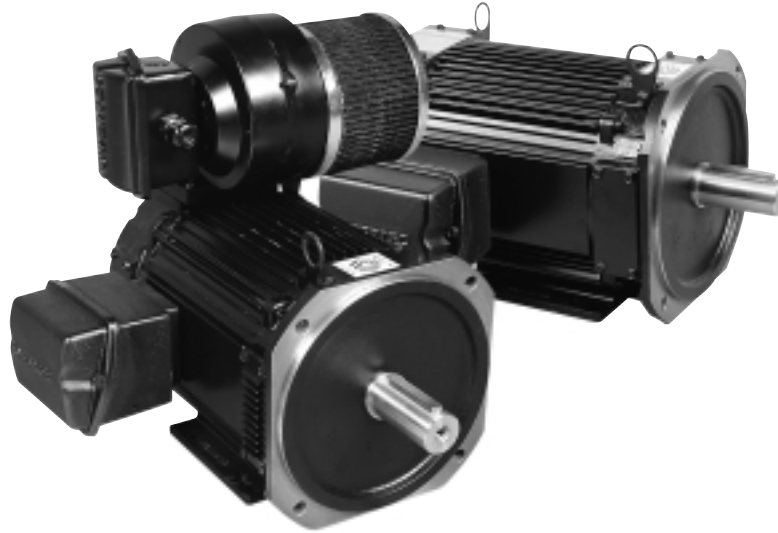

## MODEL NUMBER CODE...E180 FRAME

To construct a motor listing, select the combination of features required and put all the coded information in the proper sequence. Please account for all entries. The model number shown is an example of a properly specified motor.

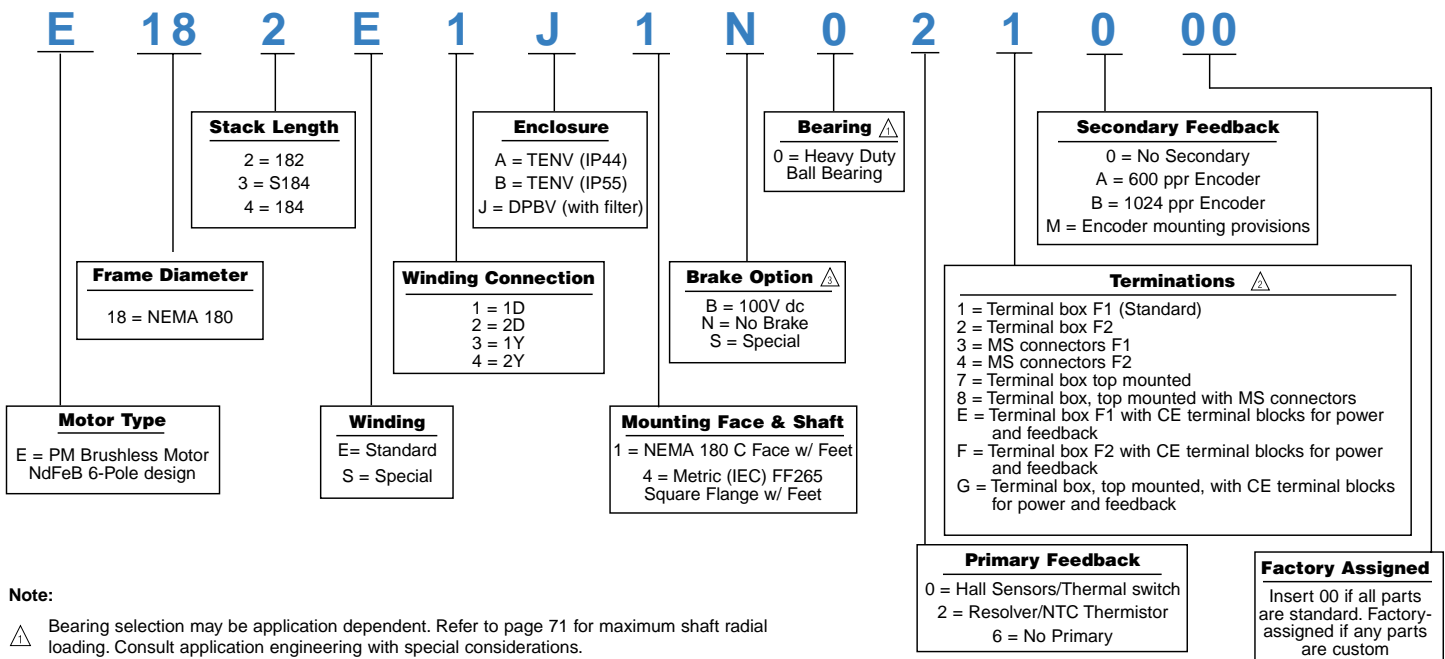

**Note:**

- ⚠ Bearing selection may be application dependent. Refer to page 71 for maximum shaft radial loading. Consult application engineering with special considerations.
- ⚠ Terminal box top option not available with DPBV motor enclosures.
- ⚠ See page 68 for a detailed list of special options.

# E180 DIAMETER FRAMES



## RATINGS AND CHARACTERISTICS

Motor parameters and winding data

### ENGLISH

### METRIC

Parameters, DPBV & TENV	Symbol	Units	E182	E183	E184	Symbol	Units	E182	E183	E184
Continuous stall torque $\triangle \triangle$	T <sub>CS</sub>	lb-ft	41 (16)	66 (29)	86 (38)	T <sub>CS</sub>	Nm	56 (22)	90 (39)	116 (51)
Peak Torque (theoretical) $\triangle$	T <sub>PK</sub>	lb-ft	164	250	335	T <sub>PK</sub>	Nm	222	339	454
Inertia (motor only)	J <sub>M</sub>	lb-ft-sec <sup>2</sup>	.00936	.01180	.01420	J <sub>M</sub>	kgm <sup>2</sup> x 10 <sup>-3</sup>	12,7	16,0	19,3
Static friction (max.)	T <sub>I</sub>	lb-ft	.058	.086	.313	T <sub>I</sub>	Nm	.079	.117	.424
Viscous Damping coefficient $\triangle$	K <sub>DV</sub>	lb-ft/Krpm	.432	.649	.681	K <sub>DV</sub>	Nm/Krpm	.585	.879	.923
Thermal resistance $\triangle$	R <sub>TH</sub>	°C/Watt	.073 (.380)	.050 (.250)	.047 (.235)	R <sub>TH</sub>	°C/Watt	.073 (.380)	.050 (.250)	.047 (.235)
Thermal time constant $\triangle$	τ <sub>TH</sub>	min.	31 (160)	30 (150)	31 (150)	τ <sub>TH</sub>	min.	31 (161)	30 (150)	31 (150)
Weight $\triangle$	W	lbs.	86 (80)	113 (107)	129 (123)	M (mass)	kg	39,1 (36,4)	51,4 (48,6)	58,6 (55,9)

Winding data	Symbol	Units	E182				E183				E184			
			E1	E2	E3	E4	E1	E2	E3	E4	E1	E2	E3	E4
Torque Constant line-line $\triangle$	K <sub>T</sub> rms	lb-ft/A	2.78	1.39	4.82	2.41	2.87	1.43	4.96	2.48	2.81	1.40	4.86	2.43
			3.77	1.88	6.53	3.26	3.89	1.94	6.73	3.37	3.80	1.90	6.59	3.30
Voltage Constant line-line $\triangle$	K <sub>E</sub> rms	V/Krpm	228	114	395	197	235	118	407	204	230	115	398	199
			2.18	1.09	3.77	1.89	2.24	1.12	3.89	1.94	2.20	1.10	3.80	1.90
Continous stall current $\triangle \triangle \triangle$	I <sub>CS</sub>	A	16(6.2)	32(12)	9.5(3.7)	19(7.4)	25(11)	51(22)	14.7(6.5)	30(13)	49(21)	67(29)	19(8.3)	38(16)
Current at peak torque $\triangle \triangle \triangle$	I <sub>PK</sub>	A	59	118	34	68	88	177	51	102	120	239	69	138
Hot Resistance line-line $\triangle$	R <sub>H</sub>	Ohms	3.14	0.78	9.41	2.35	2.02	0.48	5.60	1.41	1.16	0.29	3.49	0.87
Cold Resistance line-line $\triangle$	R <sub>C</sub>	Ohms	2.16	0.54	6.48	1.62	1.39	0.33	3.86	0.97	0.80	0.20	2.40	0.60
Inductance line-line	L	mH	25.8	6.45	77.4	19.4	16.8	4.2	50.3	12.6	12	3.00	36.0	9.00
Electrical time constant $\triangle$	τ <sub>e</sub>	msec	11.9	11.9	11.9	11.9	12.6	12.6	12.6	12.6	15	15	15	15
Mechanical time constant $\triangle$	τ <sub>m</sub>	msec	2.88	2.88	2.88	2.88	2.03	2.03	2.03	2.03	1.59	1.59	1.59	1.59
Rated base speed $\triangle$	ω <sub>r</sub>	rpm	1750	3600	1000	2000	1750	3600	1000	2000	1750	3600	1000	2000
Rated current @ rated speed, RMS Amperes	I <sub>R</sub>	A	14.8	26.8	8.8	16.9	24.0	44.0	14.3	27.4	31.5	56.2	18.9	36.0
			(3.6)	(N/A)	(3.0)	(3.4)	(8.2)	(N/A)	(5.7)	(8.6)	(10.3)	(N/A)	(7.5)	(10.4)
Power @ rated speed $\triangle$	P <sub>R</sub>	HP, DPBV (TENV)	12.8	23.7	7.6	14.5	20.8	38.7	12.2	23.5	26.9	49.0	15.9	30.2
			(3.0)	(N/A)	(2.5)	(2.7)	(6.8)	(N/A)	(4.8)	(7.0)	(8.4)	(N/A)	(6.2)	(8.4)
Power @ rated speed $\triangle$	P <sub>R</sub>	kW, DPBV (TENV)	9.6	17.7	5.7	10.8	15.6	28.9	9.1	17.5	20.2	36.5	11.9	22.5
			(2.2)	(N/A)	(1.9)	(2.0)	(5.1)	(N/A)	(3.6)	(5.2)	(6.3)	(N/A)	(4.6)	(6.3)

Note: All values at 40°C unless otherwise noted.

- $\triangle$  25°C ambient temperature
- $\triangle$  ( ) denotes TENV when dual ratings are shown. Single ratings apply to both
- $\triangle$  Based on RMS (sine wave) amps
- $\triangle$  140°C winding temperature
- $\triangle$  640V dc
- $\triangle$  Theoretical (cold) ratings at peak current, I<sub>PK</sub>. For ratings at rated temperature, see Torque-Speed curves, pages 10-12
- $\triangle$  Demagnetization current for 150°C magnet temperature

# DIMENSIONS ... 180 Diameter Frames; DPBV (Dripproof, Blower Ventilated)

## FRONT VIEW

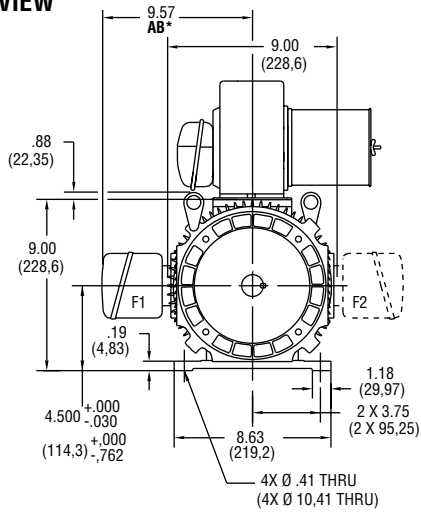

## SIDE VIEW

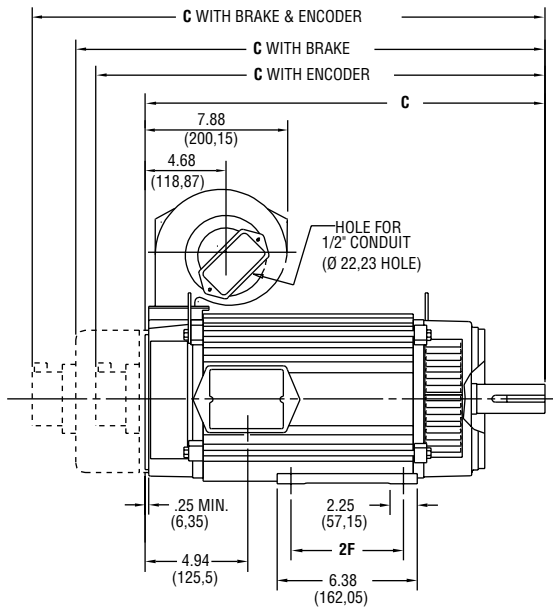

CALLOUT FOR "C" DIMENSION				
MODEL	MOTOR ONLY	WITH ENCODER	WITH BRAKE	WITH BRAKE & ENCODER
E182	16.63 (422,4)	19.42 (493,3)	20.52 (521,2)	22.48 (571)
E183	20.44 (519,2)	22.23 (590)	24.33 (618)	26.29 (667,8)
E184	20.44 (519,2)	23.23 (590)	24.33 (618)	26.29 (667,8)

MODEL	2F DIMENSION
E182	4.50 (114,3)
E183	5.50 (139,7)
E184	5.50 (139,7)

Dimensions in ( ) are mm, all others in inches

## REAR VIEW

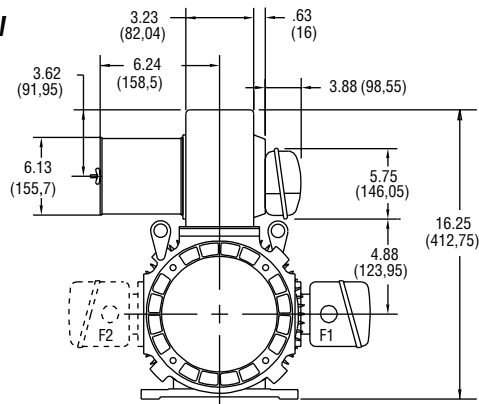

### NOTE:

- Reference pages 56, 57 for conduit box dimensions.
- Conduit box can be rotated in 90° steps on its own axis and can be mounted on opposite side or top when specified.
- Blower can be rotated 180° about its axis. Size #2 blower is used on E180 frames. See Page 67.

\* See terminations, page 56.

# DIMENSIONS ... 180 Diameter Frames; TENV (Totally Enclosed, Non-Ventilated)

## FRONT VIEW

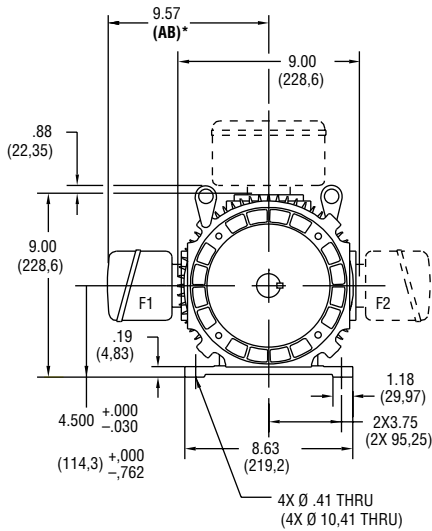

## SIDE VIEW

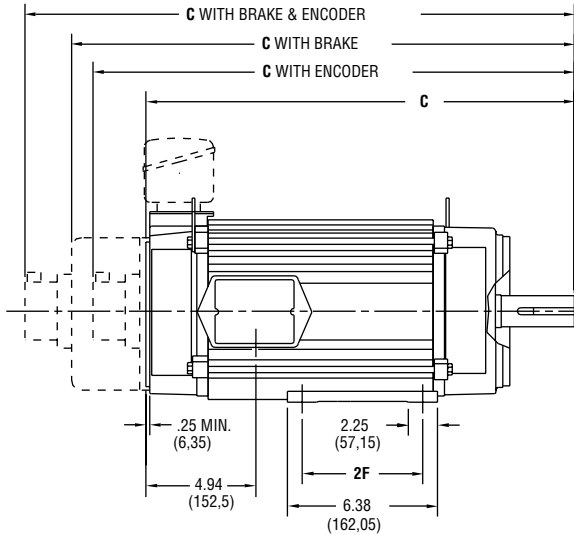

CALLOUT FOR "C" DIMENSION				
MODEL	MOTOR ONLY	WITH ENCODER	WITH BRAKE	WITH BRAKE & ENCODER
E182	16.63 (422,4)	19.42 (493,3)	20.52 (521,2)	22.48 (571)
E183	20.44 (519,2)	22.23 (590)	24.33 (618)	26.29 (667,8)
E184	20.44 (519,2)	23.23 (590)	24.33 (618)	26.29 (667,8)

MODEL	2F DIMENSION
E182	4.50 (114,3)
E183	5.50 (139,7)
E184	5.50 (139,7)

Dimensions in ( ) are mm, all others in inches

## REAR VIEW

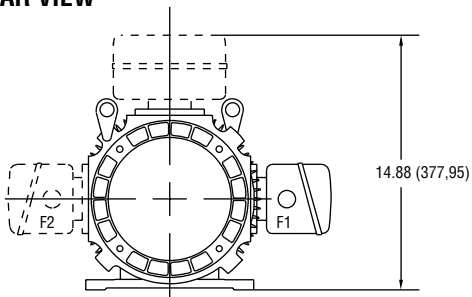

### NOTE:

1. Reference pages 56, 57 for conduit box dimensions.
2. Conduit box can be rotated in 90° steps on its own axis and can be mounted on opposite side or top when specified.

\* See terminations, page 56.

# DIMENSIONS . . . 180 Diameter Frame Mounting; NEMA and Metric

## NEMA C FACE

Dimensions in inches

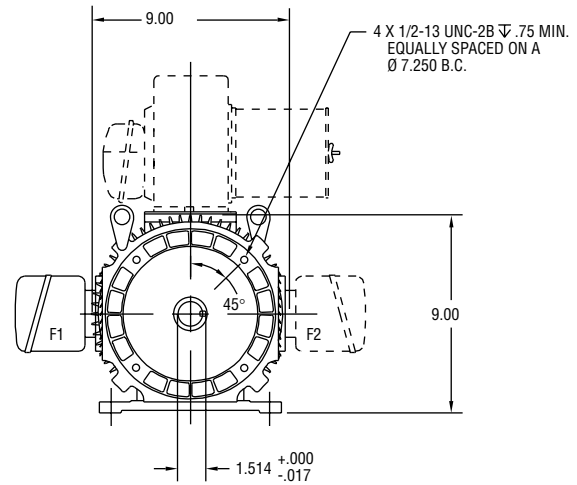
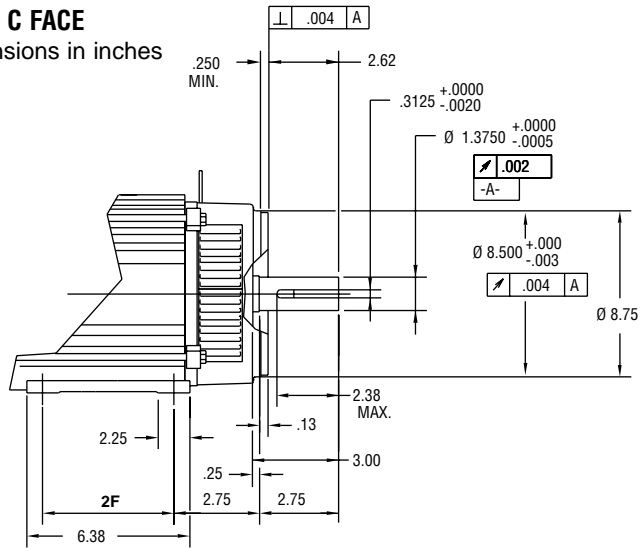

REFER TO DPBV, PAGE 7 FOR FRONT VIEW FEET DIMENSIONS.

MODEL	2F DIMENSION
E182	4.50
E183	5.50
E184	5.50

## ALTERNATE MOUNTING

Metric (IEC) FF265

Dimensions in mm

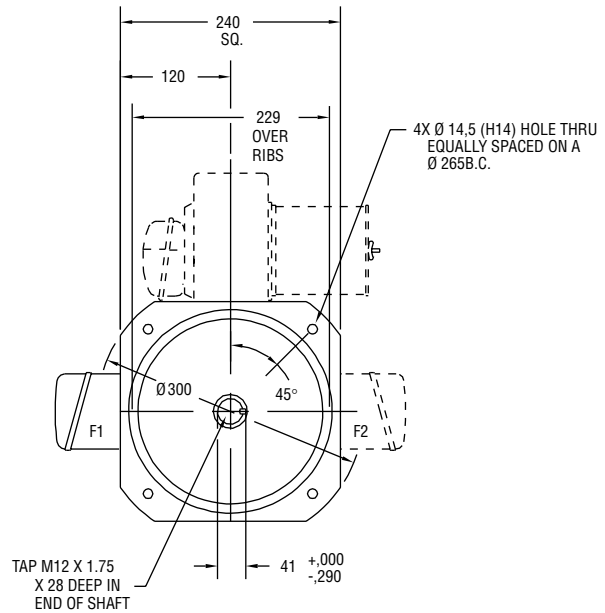
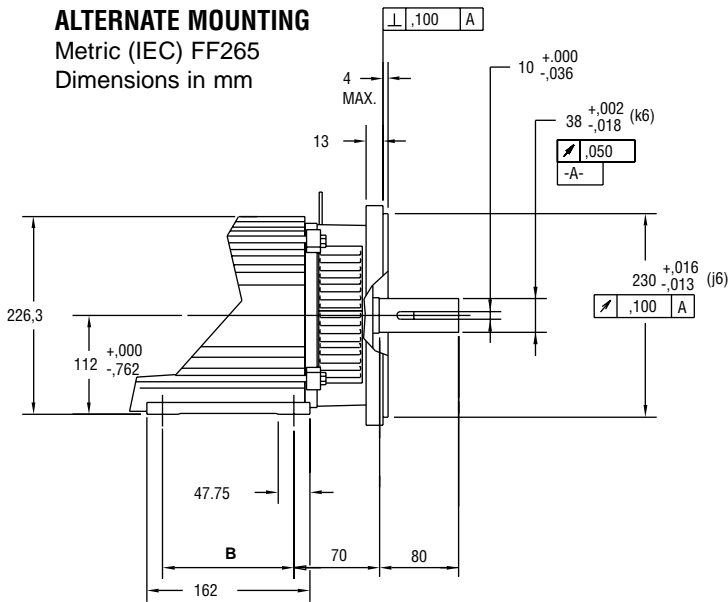

EXCEPT FOR FOOT HEIGHT REFER TO DPBV, PAGE 7 FOR FRONT VIEW FEET DIMENSIONS.



MODEL	B DIMENSION
E182	114,3
E183	139,7
E184	139,7

# PERFORMANCE CURVES

## 180 FRAME E182

### Test Conditions



- Motor operated in ambient temperature of 40° C maximum that results in a maximum motor stator winding temperature of 140° C
- 640V dc bus applied
- Sinusoidal drive output

-  Intermittent duty
-  Continuous duty

### DPBV DRIPPROOF BLOWER VENTILATED

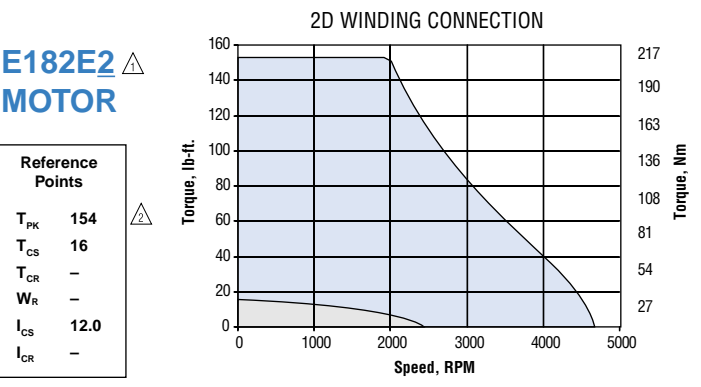
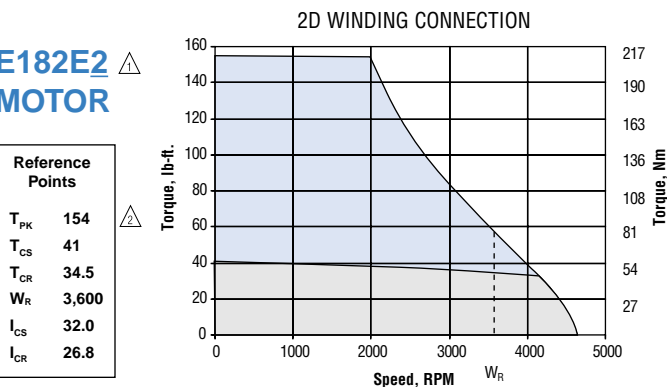
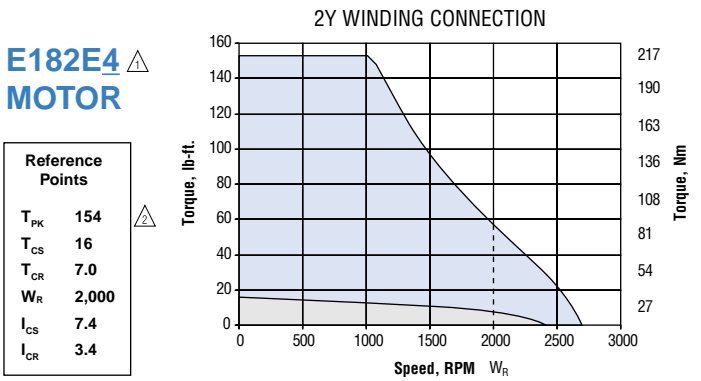
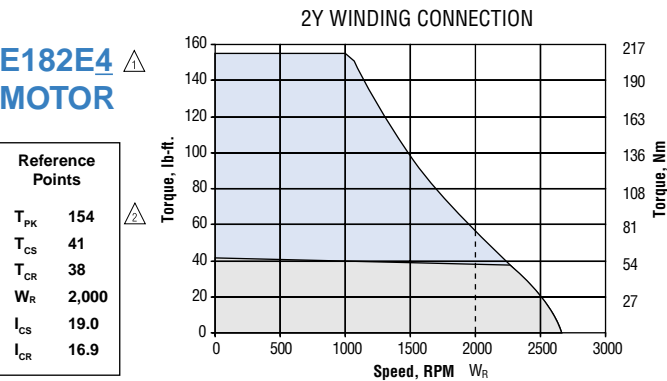
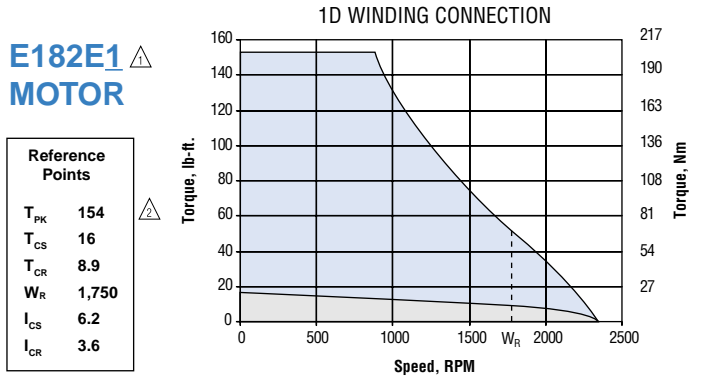
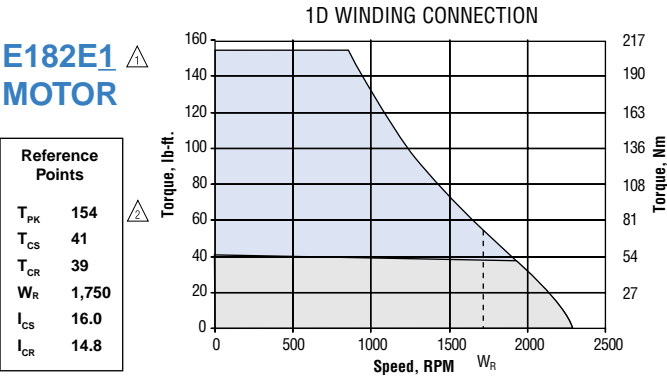
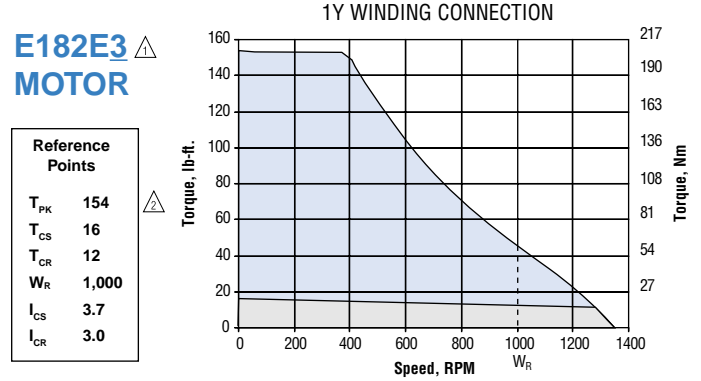
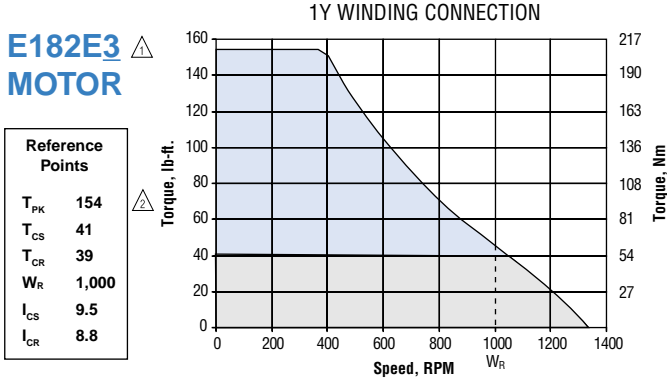
### TENV TOTALLY ENCLOSED NON-VENTILATED



-  See model number code, page 5.
-  This is also the demagnetization limit. User should apply appropriate safety margins in its use.

- Notes:
1. See Motor Performance Curves, page 76.
  2. See Thermal Protection, page 69.
  3. See Power Curves, page 13.
  4. See Efficiency Curves, page 14.

# PERFORMANCE CURVES

## 180 FRAME E183 (NEMA ES184)

### Test Conditions

- Motor operated in ambient temperature of 40° C maximum that results in a maximum motor stator winding temperature of 140° C
- 640V dc bus applied
- Sinusoidal drive output

- Intermittent duty
- Continuous duty

### DPBV DRIPPROOF BLOWER VENTILATED

### TENV TOTALLY ENCLOSED NON-VENTILATED

#### E183E3 MOTOR

Reference Points	
$T_{PK}$	230
$T_{CS}$	66
$T_{CR}$	64
$W_R$	1,000
$I_{CS}$	14.7
$I_{CR}$	14.3

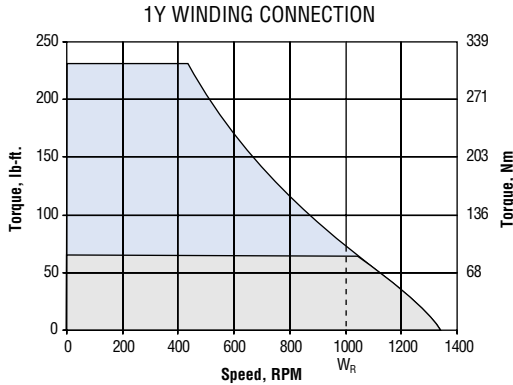

#### E183E3 MOTOR

Reference Points	
$T_{PK}$	230
$T_{CS}$	29
$T_{CR}$	25
$W_R$	1,000
$I_{CS}$	6.5
$I_{CR}$	5.7

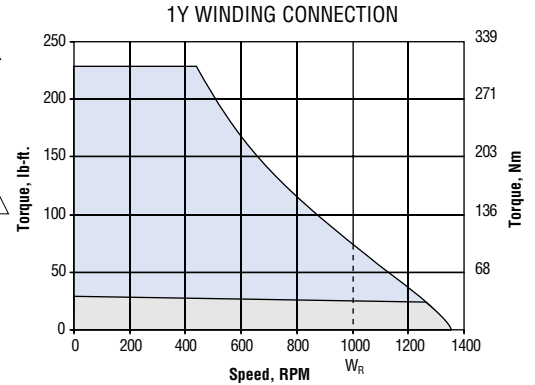

#### E183E1 MOTOR

Reference Points	
$T_{PK}$	230
$T_{CS}$	66
$T_{CR}$	62
$W_R$	1,750
$I_{CS}$	25.0
$I_{CR}$	24.0

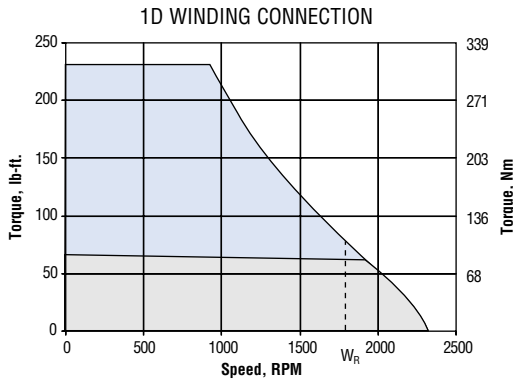

#### E183E1 MOTOR

Reference Points	
$T_{PK}$	230
$T_{CS}$	29
$T_{CR}$	20
$W_R$	1,750
$I_{CS}$	11.0
$I_{CR}$	8.2

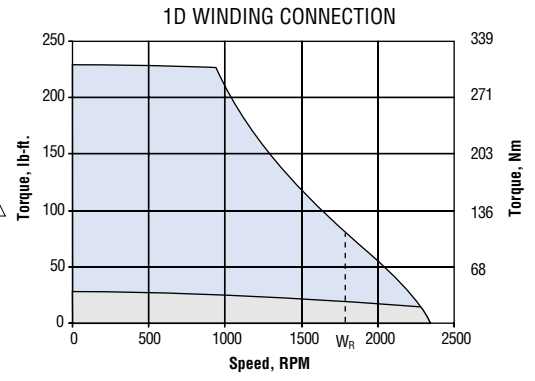

#### E183E4 MOTOR

Reference Points	
$T_{PK}$	230
$T_{CS}$	66
$T_{CR}$	61
$W_R$	2,000
$I_{CS}$	30.0
$I_{CR}$	27.4

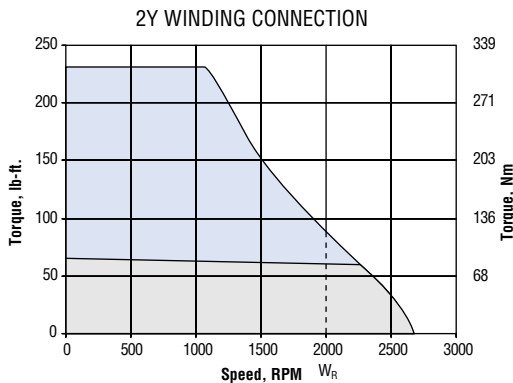

#### E183E4 MOTOR

Reference Points	
$T_{PK}$	230
$T_{CS}$	29
$T_{CR}$	18.4
$W_R$	2,000
$I_{CS}$	13.0
$I_{CR}$	8.6

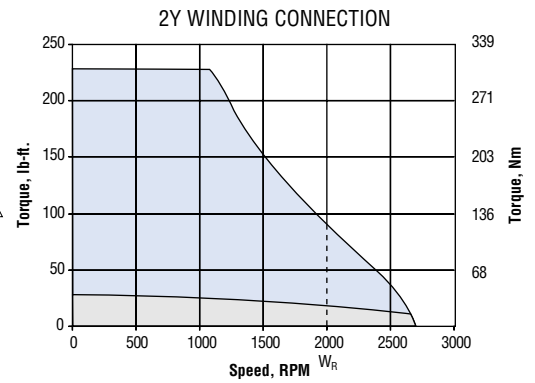

#### E183E2 MOTOR

Reference Points	
$T_{PK}$	230
$T_{CS}$	66
$T_{CR}$	56
$W_R$	3,600
$I_{CS}$	51.0
$I_{CR}$	44

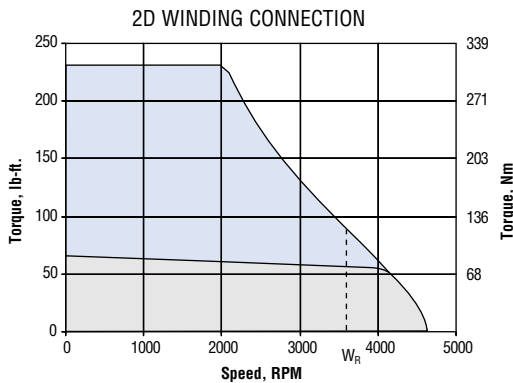

#### E183E2 MOTOR

Reference Points	
$T_{PK}$	230
$T_{CS}$	29
$T_{CR}$	-
$W_R$	-
$I_{CS}$	22.0
$I_{CR}$	-

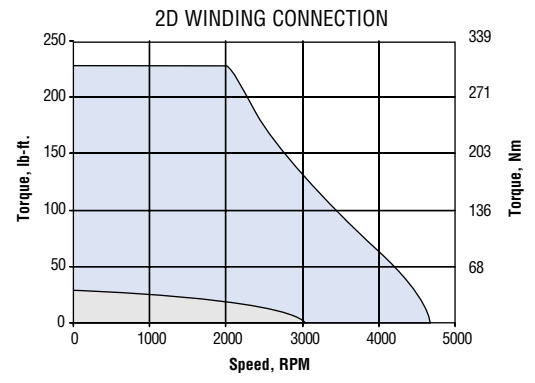

- △ See model number code, page 5.
- △ This is also the demagnetization limit. User should apply appropriate safety margins in its use.



- Notes:
1. See Motor Performance Curves, page 76.
  2. See Thermal Protection, page 69.
  3. See Power Curves, page 13.
  4. See Efficiency Curves, page 14.

# PERFORMANCE CURVES

## 180 FRAME E184

### Test Conditions

- Motor operated in ambient temperature of 40° C maximum that results in a maximum motor stator winding temperature of 140° C
- 640V dc bus applied
- Sinusoidal drive output

-  Intermittent duty
-  Continuous duty

### DPBV DRIPPROOF BLOWER VENTILATED

### TENV TOTALLY ENCLOSED NON-VENTILATED

#### E184E3 MOTOR

Reference Points	
$T_{PK}$	310
$T_{CS}$	86
$T_{CR}$	83
$W_R$	1,000
$I_{CS}$	19.0
$I_{CR}$	18.9

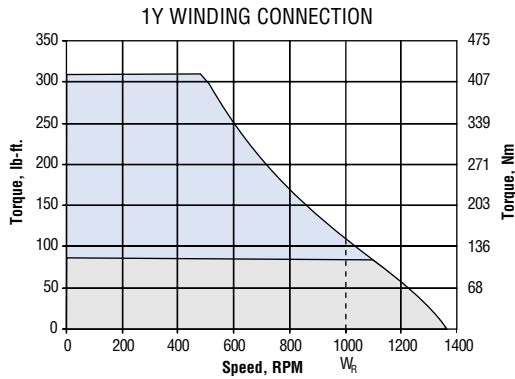

#### E184E3 MOTOR

Reference Points	
$T_{PK}$	310
$T_{CS}$	38
$T_{CR}$	32
$W_R$	1,000
$I_{CS}$	8.3
$I_{CR}$	7.5

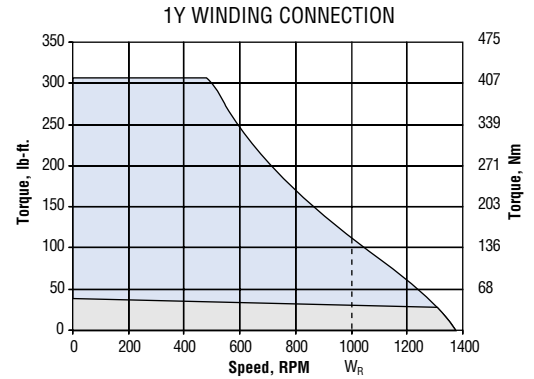

#### E184E1 MOTOR

Reference Points	
$T_{PK}$	310
$T_{CS}$	86
$T_{CR}$	79
$W_R$	1,750
$I_{CS}$	49.0
$I_{CR}$	31.5

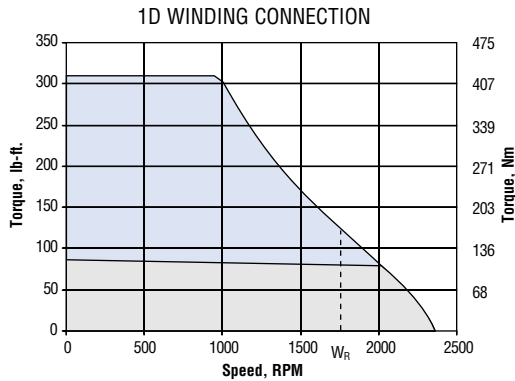

#### E184E1 MOTOR

Reference Points	
$T_{PK}$	310
$T_{CS}$	38
$T_{CR}$	25
$W_R$	1,750
$I_{CS}$	21.0
$I_{CR}$	10.3

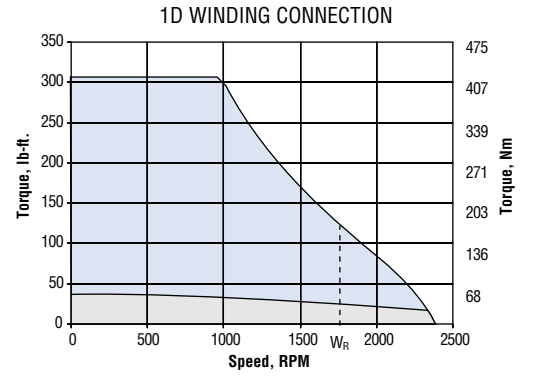

#### E184E4 MOTOR

Reference Points	
$T_{PK}$	310
$T_{CS}$	86
$T_{CR}$	79
$W_R$	2,000
$I_{CS}$	38.0
$I_{CR}$	36.0

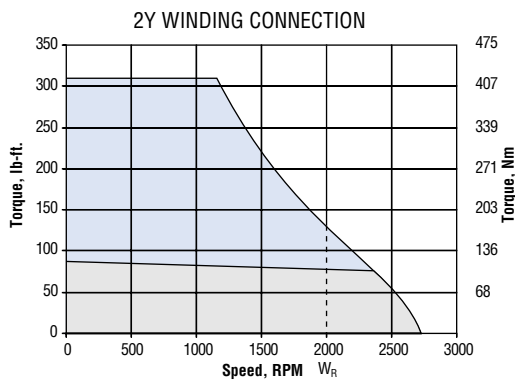

#### E184E4 MOTOR

Reference Points	
$T_{PK}$	310
$T_{CS}$	38
$T_{CR}$	22
$W_R$	2,000
$I_{CS}$	16.0
$I_{CR}$	10.4

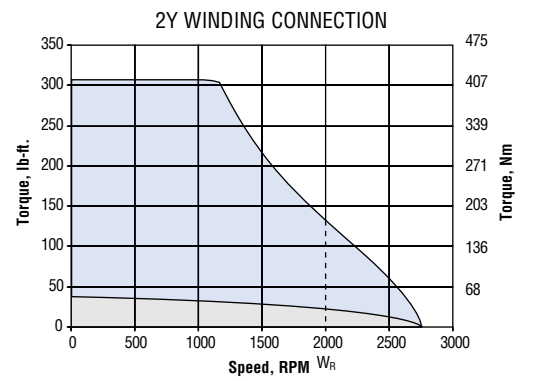

#### E184E2 MOTOR

Reference Points	
$T_{PK}$	310
$T_{CS}$	86
$T_{CR}$	71
$W_R$	3,600
$I_{CS}$	67.0
$I_{CR}$	56.2

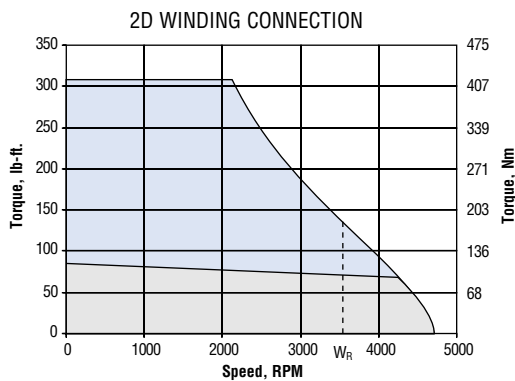

#### E184E2 MOTOR

Reference Points	
$T_{PK}$	310
$T_{CS}$	38
$T_{CR}$	-
$W_R$	-
$I_{CS}$	29.0
$I_{CR}$	-

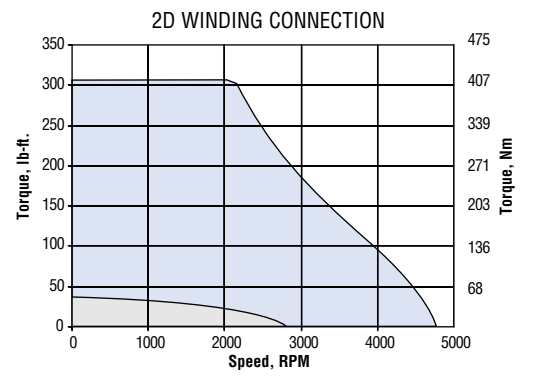

- △ See model number code, page 5.
- △ This is also the demagnetization limit. User should apply appropriate safety margins in its use.

- Notes:
1. See Motor Performance Curves, page 76.
  2. See Thermal Protection, page 69.
  3. See Power Curves, page 13.
  4. See Efficiency Curves, page 14.

# CONTINUOUS POWER CURVES

## E180 DIAMETER FRAMES

Standard E180 frame motors are limited (mechanical design) to 6000 RPM. Special designs are available that allow operation to speeds indicated in the individual curves.

One power curve is shown for each stack length in both the DPBV and TENV enclosures. Four different winding connections are offered for each stack length, but the power curve is the same for all connections. Therefore, only one power curve is necessary for each stack length and enclosure.

### DPBV DRIPPROOF BLOWER VENTILATED

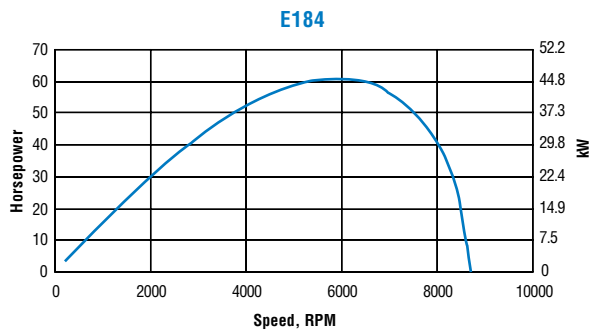
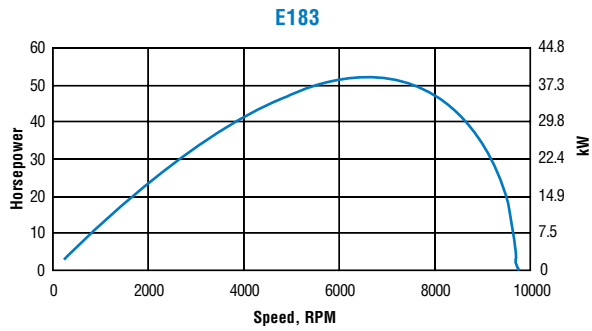
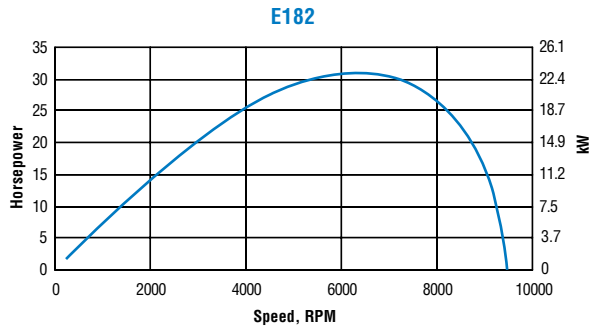

### TENV TOTALLY ENCLOSED NON-VENTILATED

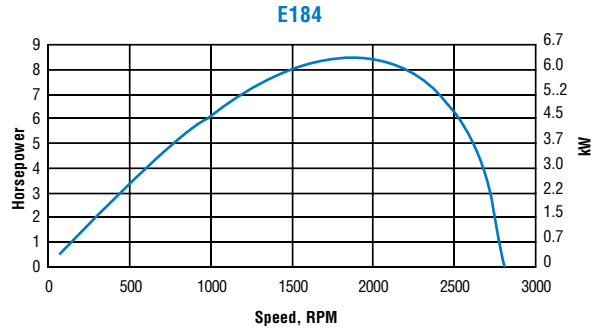
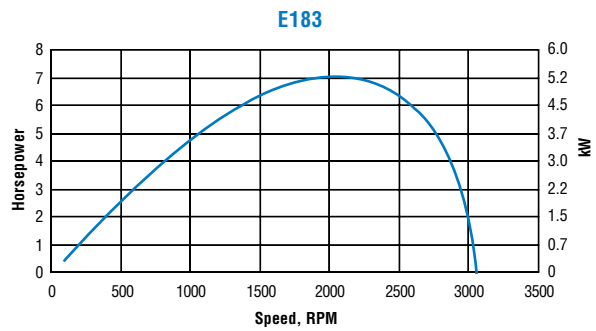
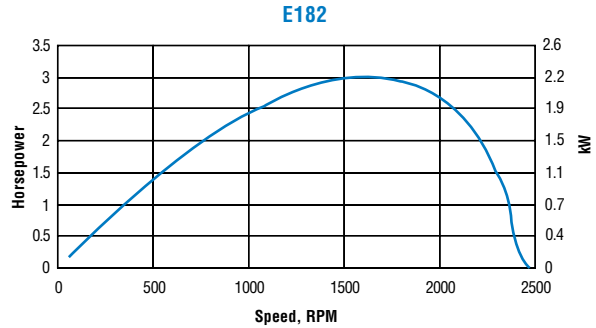

Note: see Motor Performance Curves, page 76.

# EFFICIENCY CURVES

## E180 DIAMETER

### FRAMES

One efficiency curve is shown for each stack length. Efficiencies for the DPBV and TENV enclosures are approximately the same, so a single curve represents both. In addition, although four different winding connections are offered for each stack length, the efficiency is the same for all connections.

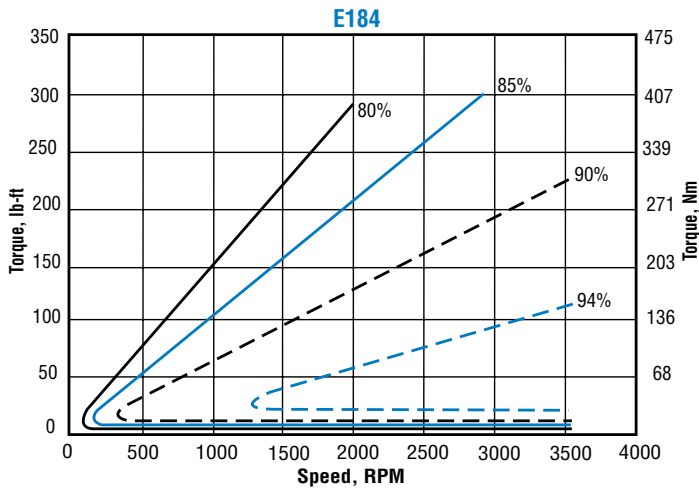
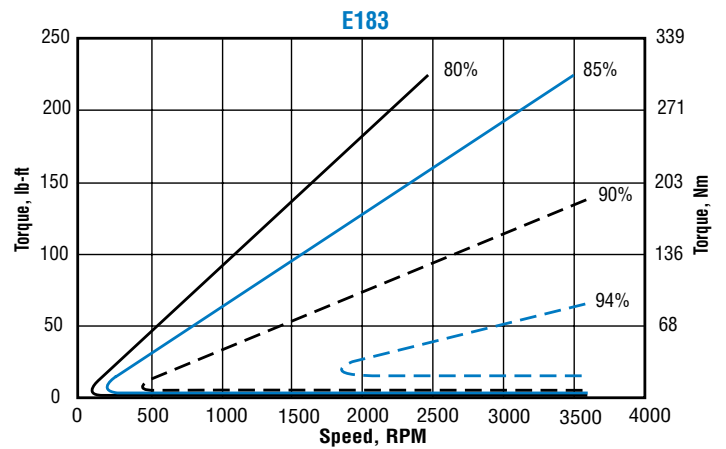
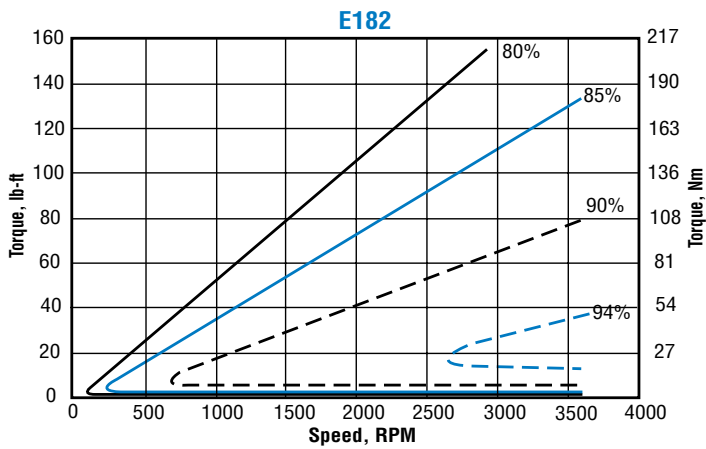

Note: see Motor Performance Curves, page 76.