

CMC AC Variable Speed Drive

Action Master

Series **S**

1 - 30 HP (230/460V)

**Installation, Operation and
Maintenance Instruction**



**Read this manual carefully before installing, wiring,
operating, servicing or inspecting the drive.
Keep this manual within easy reach for quick reference.**

CMC **Cleveland**
Motion Controls
An **IMC** Company

Thank you for purchasing CMC Variable Frequency Drives !

SAFETY INSTRUCTIONS

- Always follow safety instructions to prevent accidents and potential hazards from occurring.
- In this manual, safety messages are classified as follows:



WARNING

Improper operation may result in serious personal injury or death.



CAUTION

Improper operation may result in slight to medium personal injury or property damage.

- Throughout this manual we use the following two illustrations to make you aware of safety considerations:



Identifies potential hazards under certain conditions.
Read the message and follow the instructions carefully.



Identifies shock hazards under certain conditions.
Particular attention should be directed because dangerous voltage may be present.

- Keep operating instructions handy for quick reference.
- Read this manual carefully to maximize the performance of the ACtionMaster series inverter and ensure its safe use.



WARNING

- **Do not remove the cover while power is applied or the unit is in operation.**
Otherwise, electric shock could occur.
- **Do not run the inverter with the front cover removed.**
Otherwise, you may get an electric shock due to high voltage terminals or charged capacitor exposure.
- **Do not remove the cover except for periodic inspections or wiring, even if the input power is not applied.**
Otherwise, you may access the charged circuits and get an electric shock.
- **Wiring and periodic inspections should be performed at least 10 minutes after disconnecting the input power and after checking the DC link voltage is discharged with a meter (below DC 30V).**
Otherwise, you may get an electric shock.

- **Operate the switches with dry hands.**
Otherwise, you may get an electric shock.
- **Do not use the cable when its insulating tube is damaged.**
Otherwise, you may get an electric shock.
- **Do not subject the cables to scratches, excessive stress, heavy loads or pinching.**
Otherwise, you may get an electric shock.



CAUTION

- **Install the inverter on a non-flammable surface. Do not place flammable material nearby.**
Otherwise, fire could occur.
- **Disconnect the input power if the inverter gets damaged.**
Otherwise, it could result in a secondary accident and fire.
- **After the input power is applied or removed, the inverter will remain hot for a couple of minutes.**
Otherwise, you may get bodily injuries such as skin-burn or damage.
- **Do not apply power to a damaged inverter or to an inverter with parts missing even if the installation is complete.**
Otherwise, electric shock could occur.
- **Do not allow lint, paper, wood chips, dust, metallic chips or other foreign matter into the drive.**
Otherwise, fire or accident could occur.

OPERATING PRECAUTIONS

(1) Handling and installation

- Handle according to the weight of the product.
- Do not stack the inverter boxes higher than the number recommended.
- Install according to instructions specified in this manual.
- Do not open the cover during delivery.
- Do not place heavy items on the inverter.
- Check the inverter mounting orientation is correct.
- Do not drop the inverter, or subject it to impact.
- Verify that the inverter is solidly grounded. Use ground impedance of 100ohm or less for 200 V Class and 10ohm or less for 400V class.
- Take protective measures against ESD (Electrostatic Discharge) before touching the pcb for inspection or installation.

- Use the inverter under the following environmental conditions:

Environment	Ambient temperature	- 10 ~ 40 °C (non-freezing)
	Relative humidity	90% RH or less (non-condensing)
	Storage temperature	- 20 ~ 65 °C
	Location	Protected from corrosive gas, combustible gas, oil mist or dust
	Altitude, Vibration	Max. 1,000m above sea level, Max. 5.9m/sec ² (0.6G) or less
	Atmospheric pressure	70 ~ 106 kPa

(2) Wiring

- Do not connect a power factor correction capacitor, surge suppressor, or RFI filter to the output of the inverter.
- The connection orientation of the output cables U, V, W to the motor will affect the direction of rotation of the motor.
- Incorrect terminal wiring could result in the equipment damage.
- Reversing the polarity (+/-) of the terminals could damage the inverter.
- Only authorized personnel familiar with CMC inverter should perform wiring and inspections.
- Always install the inverter before wiring. Otherwise, you may get an electric shock or have bodily injury.

(3) Trial run

- Check all parameters during operation. Changing parameter values might be required depending on the load.
- Always apply permissible range of voltage to the each terminal as indicated in this manual. Otherwise, it could lead to inverter damage.

(4) Operation precautions

- When the Auto restart function is selected, stay away from the equipment as a motor will restart suddenly after an alarm stop.
- The Stop key on the keypad is valid only when the appropriate function setting has been made. Prepare an emergency stop switch separately.
- If an alarm reset is made with the reference signal present, a sudden start will occur. Check that the reference signal is turned off in advance. Otherwise an accident could occur.
- Do not modify or alter anything inside the inverter.
- Motor might not be protected by electronic thermal function of inverter.
- Do not use a magnetic contactor on the inverter input for frequent starting/stopping of the inverter.
- Use a noise filter to reduce the effect of electromagnetic interference. Otherwise nearby electronic equipment may be affected.
- In case of input voltage unbalance, install AC reactor. Power Factor capacitors and generators may become overheated and damaged due to potential high frequency noise transmitted from inverter.

- Use an insulation-rectified motor or take measures to suppress the micro surge voltage when driving 400V class motor with inverter. A micro surge voltage attributable to wiring constant is generated at motor terminals, and may deteriorate insulation and damage motor.
- Before operating unit and prior to user programming, reset user parameters to default settings.
- Inverter can easily be set to high-speed operations, Verify capability of motor or machinery prior to operating unit.
- Stopping torque is not produced when using the DC-Break function. Install separate equipment when stopping torque is needed.

(5) Fault prevention precautions

- Provide a safety backup such as an emergency brake which will prevent the machine and equipment from hazardous conditions if the inverter fails.

(6) Maintenance, inspection and parts replacement

- Do not conduct a megger (insulation resistance) test on the control circuit of the inverter.
- Refer to Chapter 8 for periodic inspection (parts replacement).

(7) Disposal

- Handle the inverter as an industrial waste when disposing of it.

(8) General instructions

- Many of the diagrams and drawings in this instruction manual show the inverter without a circuit breaker, a cover or partially open. Never run the inverter like this. Always place the cover with circuit breakers and follow this instruction manual when operating the inverter.

CONTENTS

USER SELECTION GUIDE (ACTIONMASTER SPECIFICATIONS)	II
CHAPTER 1 - INSTALLATION	1-2
1.1 Inspection	1-2
1.2 Environmental Conditions	1-2
1.3 Mounting	1-2
1.4 Other Precautions	1-2
1.5 Dimensions	1-2
1.6 Basic Wiring	1-2
1.7 Power Terminals	1-2
1.8 Control Terminals	1-2
CHAPTER 2 - OPERATION	2-2
2.1 Parameter Groups	2-2
2.2 LCD Keypad	2-2
2.3 7-Segment Keypad	2-2
2.4 Operation Method	2-2
CHAPTER 3 - QUICK-START PROCEDURES	3-2
3.1 Operation using Keypad	3-2
3.2 Operation using Control Terminals	3-2
3.3 Operation using Keypad and Control Terminals	3-2
CHAPTER 4 - VARIOUS FUNCTION SETTING & DESCRIPTION	4-2
4.1 Function Setting	4-2
4.2 Operation Example	4-2
CHAPTER 5 - PARAMETER LIST	5-2
5.1 Drive Group [DRV]	5-2
5.2 Function 1 Group [FU1]	5-2
5.3 Function 2 Group [FU2]	5-2
5.4 Input/Output Group [I/O]	5-2
5.5 External Group [EXT]	5-2
5.6 Communication Group [COM]	5-2
5.7 Application Group [APP]	5-2
5.8 Sub-Board Selection Guide According To Function	5-2
CHAPTER 6 - PARAMETER DESCRIPTION	6-2
6.1 Drive group [DRV]	6-2
6.2 Function 1 Group [FU1]	6-2
6.3 Function 2 Group [FU2]	6-2
6.4 Input/Output Group [I/O]	6-2
6.5 External Group [EXT]	6-2

6.6	Application Group [APP].....	6-2
CHAPTER 7 - OPTIONS		7-2
7.1	Sub-A board	7-2
7.2	Sub-B Board	7-2
7.3	Sub-C Board (Isolated)	7-2
7.4	Sub-D Board	7-2
7.5	Communication option boards	7-2
7.6	External options	7-2
CHAPTER 8 - TROUBLESHOOTING & MAINTENANCE		8-2
8.1	Fault Display.....	8-2
8.2	Fault Remedy	8-2
8.3	Troubleshooting.....	8-2
8.4	How to Check Power Components.....	8-2
8.5	Maintenance	8-2
8.6	Daily and Periodic Inspection Items.....	8-2
APPENDIX A - FUNCTIONS BASED ON USE		II
APPENDIX B - PARAMETERS BASED ON APPLICATION		II
APPENDIX C - PERIPHERAL DEVICES		II
DECLARATION OF CONFORMITY		II

USER SELECTION GUIDE (ActionMaster SPECIFICATIONS)

230V Class (1 ~ 30HP)

Model Number SV xxx ActionMaster - 2		008	015	022	037	055	075	110	150	185	220
Motor Rating ¹	HP	1	2	3	5	7.5	10	15	20	25	30
	kW	0.75	1.5	2.2	3.7	5.5	7.5	11	15	18.5	22
Output Ratings	Capacity ² [kVA]	1.9	3.0	4.5	6.1	9.1	12.2	17.5	22.9	28.2	33.5
	FLA [A]	5	8	12	16	24	32	46	60	74	88
	Frequency	0 ~ 400 Hz (0-120Hz for Vector control)									
	Voltage	200 ~ 230 V ³									
Input Ratings	Voltage	3 Phase, 200 ~ 230 V (± 10 %)									
	Frequency	50 ~ 60 Hz (±5 %)									
Dynamic Braking ⁴	Braking Circuit	On the Board		On the Board		On the Board (Optional Resistor)		Optional (Braking Unit, Resistor) ⁴			
	Average Braking Torque	100%		100%		150%		150%			
	Max. Continuous Braking Time	5 seconds		5 seconds		15 seconds		Controlled by Braking Unit ⁵			
	Max. Duty	3 % ED		2 % ED		5 % ED		5 % ED			
Weight [lbs]		10.1	10.1	10.6	10.8	16.5	17.0	30.4	31.5	42.8	44.1

460V Class (1 ~ 30HP)

Model Number SV xxx ActionMaster - 4		008	015	022	037	055	075	110	150	185	220
Motor Rating ¹	HP	1	2	3	5	7.5	10	15	20	25	30
	kW	0.75	1.5	2.2	3.7	5.5	7.5	11	15	18.5	22
Output Ratings	Capacity ² [kVA]	1.9	3.0	4.5	6.1	9.1	12.2	18.3	22.9	29.7	34.3
	FLA [A]	2.5	4	6	8	12	16	24	30	39	45
	Frequency	0 ~ 400 Hz (0-120Hz for Vector control)									
	Voltage	380 ~ 460 V ³									
Input Ratings	Voltage	3 Phase, 380 ~ 460 V (± 10 %)									
	Frequency	50 ~ 60 Hz (±5 %)									
Dynamic Braking ⁴	Braking Circuit	On the Board		On the Board		On the Board (Optional Resistor)		Optional (Braking Unit, Resistor) ⁴			
	Max. Braking Torque	100%		100%		150%		150%			

¹ Indicates the maximum applicable capacity when using a 4 Pole motor.

² Rated capacity ($\sqrt{3} \cdot V \cdot I$) is based on 220V for 200V class and 440V for 400V class.

³ Maximum output voltage will not be greater than the input voltage. Output voltage less than the input voltage may be programmed.

⁴ 1~5 HP inverters have internal braking resistors as standard. 7.5~10 HP inverters utilize optional braking resistors.

	Max. Continuous Baking Time	5 seconds		5 seconds		15 seconds		Controlled by Braking Unit ⁵			
	Max. Duty	3 % ED		2 % ED		5 % ED		5 % ED			
Weight [lbs]		10.4	10.4	10.6	10.8	17.0	17.0	30.6	31.7	44.1	44.1

460V Class (40 ~ 100HP)

Model Number SV xxx AActionMaster - 4		300	370	450	550	750
Motor Rating ¹	HP	40	50	60	75	100
	kW	30	37	45	55	75
Output Ratings	Capacity ² [kVA]	45	56	68	82	100
	FLA [A]	61	75	91	110	152
	Frequency	0 ~ 400 Hz (0-120Hz for Vector control)				
	Voltage	380 ~ 460 V ³				
Input Ratings	Voltage	3 Phase, 380 ~ 460 V (± 10 %)				
	Frequency	50 ~ 60 Hz (±5 %)				
Dynamic Braking ⁴	Braking Circuit	Optional (Braking Unit, Resistor) ⁴				
	Max. Braking Torque	150%				
	Max. Continuous Baking Time	Controlled by Braking Unit ⁵				
	Max. Duty	5 % ED				
Weight [lbs]		45	45	63	63	68

Common Features Specification

CONTROL	Control Method	V/F Control, Sensorless Vector Control (Speed/Torque), Sensored Vector Control (Speed/Torque) Selectable	
	Frequency Setting Resolution	Digital Reference: 0.01 Hz (Below 100 Hz), 0.1 Hz (Over 100 Hz) Analog Reference: 0.03 Hz / 60 Hz	
	Frequency Accuracy	Digital: 0.01 % of Max. Output Frequency Analog: 0.1 % of Max. Output Frequency	
	V/F Ratio	Linear, Square Pattern, User V/F	
	Overload Capacity	150 % of Rated Current for 1 Min., 200% of Rated Current for 0.5 sec. (Characteristic is Inversely Proportional to Time)	
	Torque Boost	Manual Torque Boost (0 ~ 20 %), Auto Torque Boost	
OPERATION	Input Signal	Operation Method	Key / Terminal / Communication Operation
		Frequency Setting	Analog: 0 ~ 10V / 4 ~ 20mA / Additional ports (VR: +12V, 10mA, V2: 0-10V) for Sub-Boards Digital: Keypad
		Start Signal	Forward, Reverse
		Multi-Step	Up to 8 Speeds can be Set (Use Multi-Function Terminal)
		Multi Step Accel/Decel Time	0 ~ 6,000 sec, Up to 4 Types can be Set and Selectable for Each Setting (Use Multi- Function Terminal) Accel/Decel Pattern: Linear, U-Curve, S-Curve Selectable
		Emergency Stop	Instantly Interrupts the Inverter Output

⁵ Refer to Chapter 7 Options for DBU and DB Resistors

		Jog	Jog Operation
		Auto Operation	Operates via Internal Sequence by Setting Multi-Function Terminal (5 Way * 8 Step)
		Fault Reset	Trip Status is Removed when Protection Function is Activated
	Output Sig.	Operating Status	Frequency Detection Level, Overload Alarm, Stalling, Over Voltage, Under Voltage, Inverter Overheating, Running, Stop, Constant Speed, Inverter By-Pass, Speed Searching, Auto-Operation Step, Auto-Operation Sequence
		Fault Output	Contact Output (30A, 30C, 30B) – AC 250V 1A, DC 30V 1A
		Indicator(FM,LM)	Choose 1 from Output Frequency, Output Current, Output Voltage, DC Voltage, Output Torque Output Voltage: 0 ~ 10V (for FM: Linear output, 15V Max., LM), Pulse output: 500Hz (for LM).
	Operation Function	DC Braking, Frequency Limit, Frequency Jump, Second Function, Slip Compensation, Reverse Rotation Prevention, Auto Restart, Inverter By-Pass, Auto-Tuning, PID Control	
Protective Function	Inverter Trip		Over Voltage, Under Voltage, Over Current, Fuse Open, Ground Fault, Inverter Overheating, Motor Overheating, Output Phase Open, Overload Protection, External Fault 1, 2, Communication Error, Loss of Speed Command, Hardware Fault, Option Fault etc.
	Inverter Alarm		Stall Prevention, Overload Alarm, Temperature Sensor Fault
	Momentary Power Loss		Less than 15msec: Continuous Operation, More than 15msec: Auto Restart Possible
Display	Keypad	Operation Information	Output Frequency, Output Current, Output Voltage, Frequency Value Setting, Operating Speed, DC Voltage, Output Torque
		Trip Information	Indicates a Fault when the Protection Function activates, Retains Up to 5 Faults
Environment	Ambient Temperature		-10 °C ~ 40 °C (14 °F ~ 104 °F), <i>CE Certification: 41 °F ~ 104 °F (5 °C ~ 40 °C)</i>
	Storage Temperature		-20 °C ~ 65 °C (-4 °F ~ 149 °F)
	Ambient Humidity		Less Than 90 % RH Max. (Non-Condensing), <i>CE Certification: 5 ~85% (Non-Condensing)</i>
	Altitude - Vibration		Below 1,000m or 3,300ft above sea level · Below 5.9m/sec ² (=0.6g)
	Air Pressure		86 ~ 106kPa
	Application Site		No Corrosive Gas, Combustible Gas, Oil Mist, or Dust
Cooling Method			Forced Air Cooling

CHAPTER 1 - INSTALLATION

1.1 Inspection

- Inspect the inverter for any damage that may have occurred during shipping.
- Check the nameplate on the inverter. Verify the inverter unit is the correct one for the application. The numbering system for the inverter is as shown below.

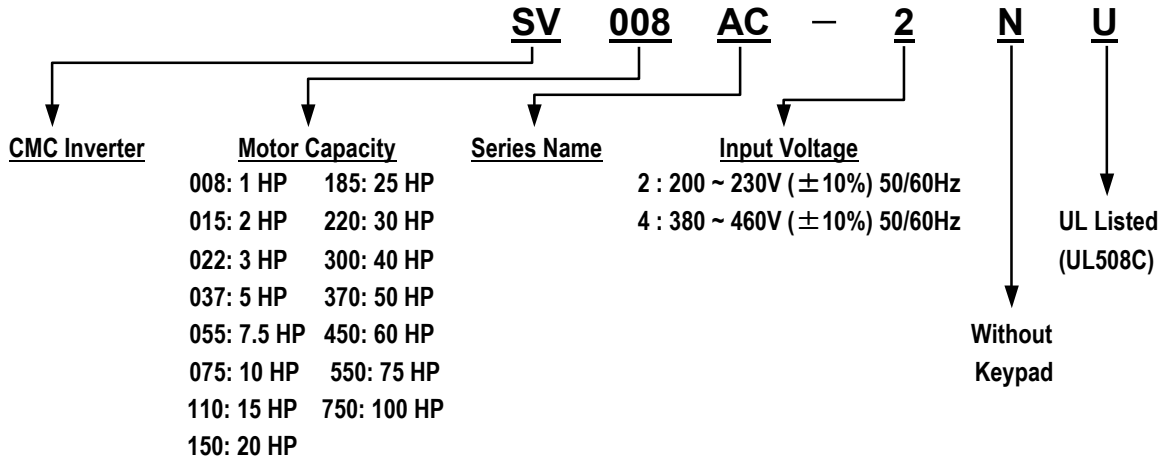

1.2 Environmental Conditions

- Verify ambient condition for the mounting location.
 - Ambient temperature should not be below 14°F (-10°C) or exceed 104°F (40°C).
 - Relative humidity should be less than 90% (non-condensing).
 - Altitude should be below 3,300ft (1,000m).
- Do not mount the inverter in direct sunlight and isolate it from excessive vibration.
- If the inverter is going to be installed in an environment with high probability of penetration of dust, it must be located inside watertight electrical boxes, in order to get the suitable IP degree.

1.3 Mounting

- The inverter must be mounted vertically with sufficient horizontal and vertical space between adjacent equipment (A= Over 6" (150mm), B= Over 2" (50mm)).

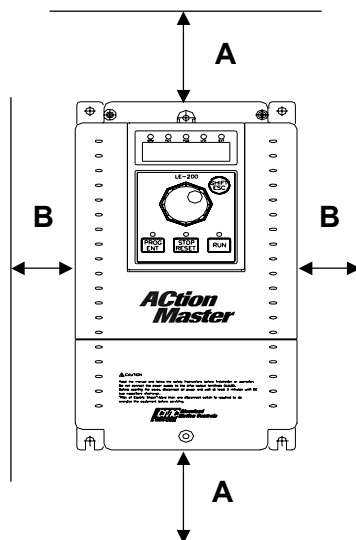

1.4 Other Precautions

- Do not carry the inverter by the front cover.
- Do not install the inverter in a location where excessive vibration is present. Be cautious when installing on presses or moving equipment.
- The life span of the inverter is greatly affected by the ambient temperature. Install in a location where temperature are within permissible limits (- 10 ~ 40 °C).
- The inverter operates at high-temperatures - install on a non-combustible surface.
- Do not install the inverter in high-temperature or high-humidity locations.
- Do not install the inverter in a location where oil mist, combustible gas, or dust is present. Install the inverter in a clean location or in an enclosed panel, free of foreign substance.
- When installing the inverter inside a panel with multiple inverters or a ventilation fan, use caution. If installed incorrectly, the ambient temperature may exceed specified limits.

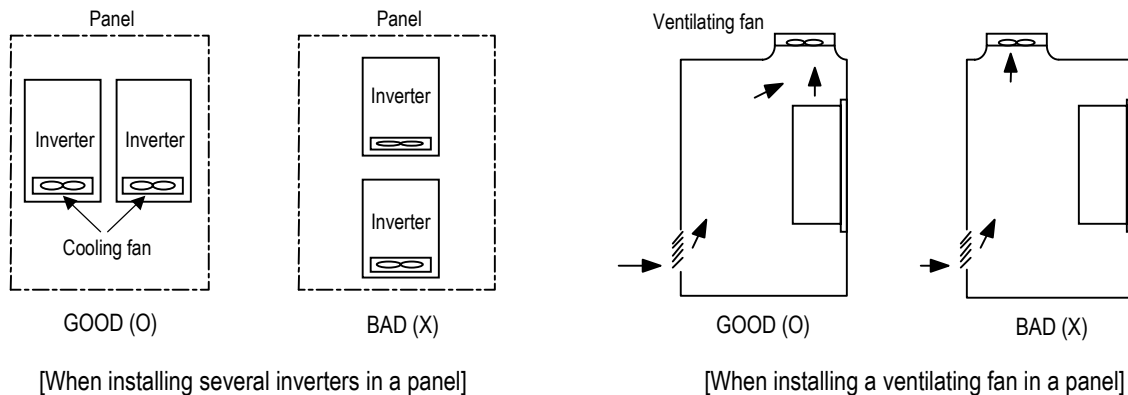

- Install the inverter using screws or bolts to insure the inverter is firmly fastened.

1.5 Dimensions

- Frame # 1: 1 ~ 5 HP
- Frame # 2: 7.5 ~ 10 HP

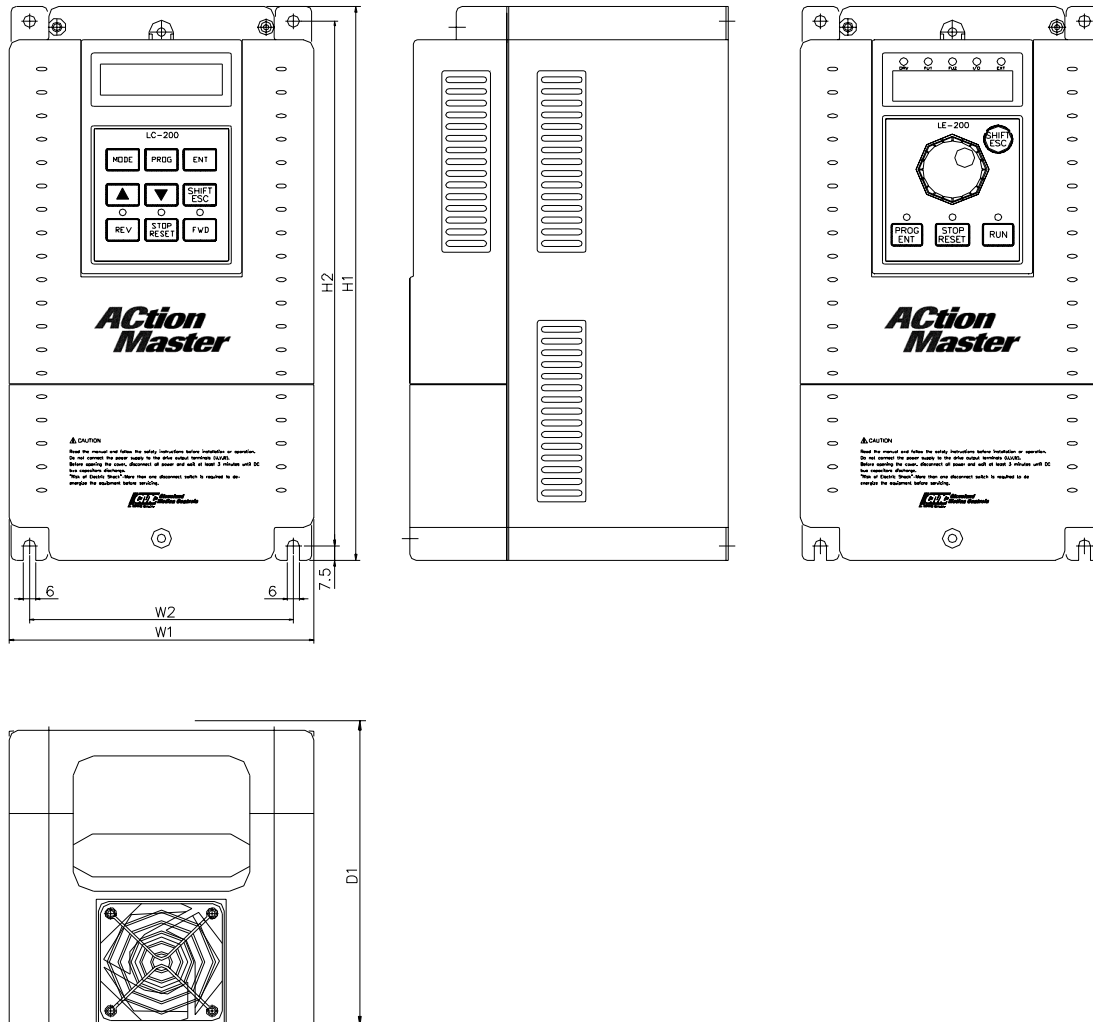

Frame	HP	Model Number	W1	W2	H1	H2	D1
Frame # 1	1	SV008ActionMaster-2/4	150 (5.91)	130 (5.12)	284 (11.18)	269 (10.69)	156.5 (6.16)
	2	SV015ActionMaster-2/4					
	3	SV022ActionMaster-2/4					
	5	SV037ActionMaster-2/4					
Frame # 2	7.5	SV055ActionMaster-2/4	200 (7.87)	180 (7.09)	355 (13.98)	340 (13.39)	182.5 (7.19)
	10	SV075ActionMaster-2/4					

BLANK

- Frame # 3: 15 ~ 20 HP
- Frame # 4: 25 ~ 30 HP

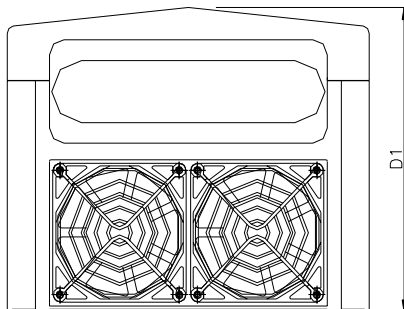
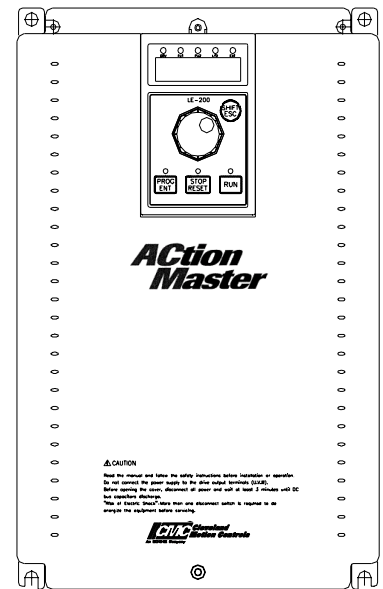
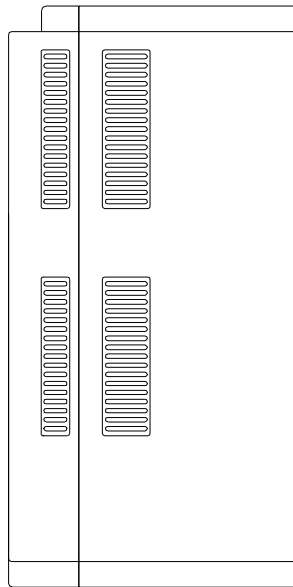
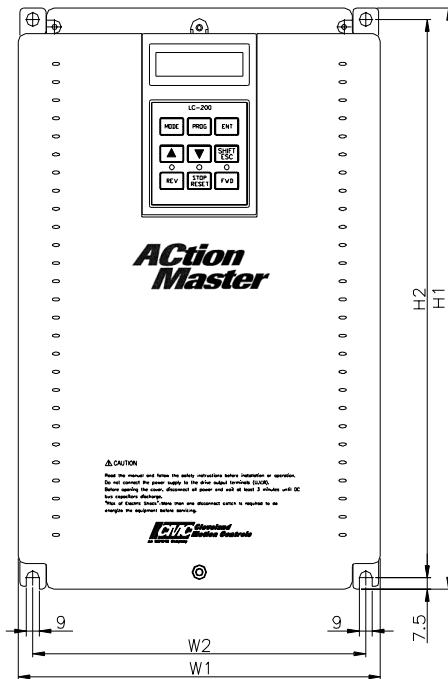

mm (inches)

Frame	HP	Model Number	W1	W2	H1	H2	D1
Frame # 3	15	SV110ActionMaster-2/4	250 (9.84)	230 (9.06)	385 (15.16)	370 (14.57)	201 (7.91)
	20	SV150ActionMaster-2/4					
Frame # 4	25	SV185ActionMaster-2/4	304 (11.97)	284 (11.18)	460 (18.11)	445 (17.52)	234 (9.21)
	30	SV220ActionMaster-2/4					

BLANK

1.6 Basic Wiring

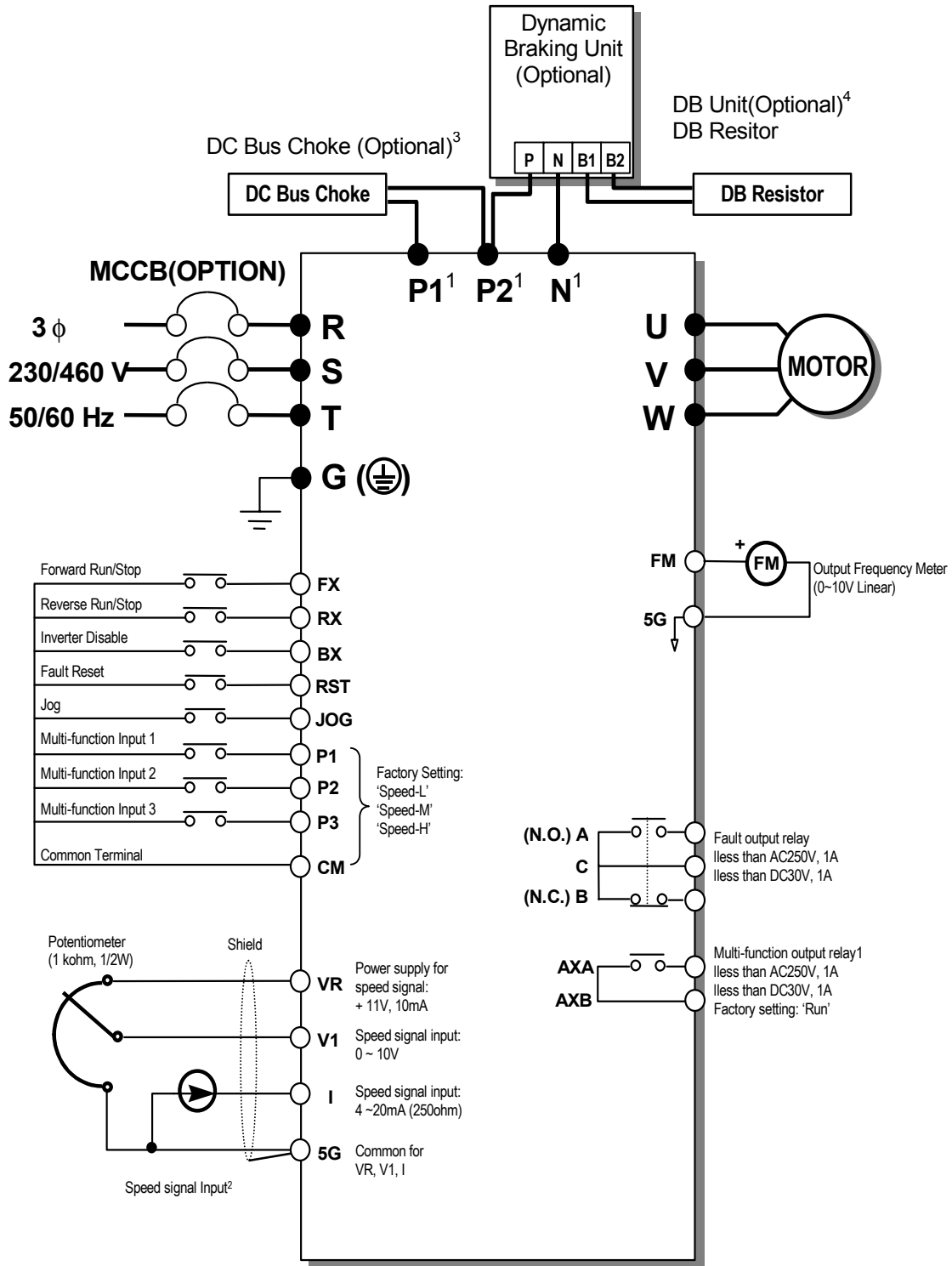

- Note) ● Main Circuit Terminals ○ Control Circuit Terminals.
1. The terminal configuration varies depend on the model number. Please refer to the '1.7 Power terminals'.
 2. Analog speed command may be set by Voltage, Current or both.
 3. When installing the DC Reactor, the Common Busbar between P1 and P2 must be removed.
 4. 1 ~ 10 HP inverters have on-board braking circuit. Braking resistors are only included for 1 ~ 5 inverters. 15 ~ 30 HP inverters need optional braking unit and resistor for dynamic braking.

1.7 Power Terminals

- **Type A Configuration: 1 ~ 5 HP** (SV008ActionMaster-2, SV015ActionMaster-2, SV022ActionMaster-2, SV037ActionMaster-2, SV008ActionMaster-4, SV015ActionMaster-4, SV022ActionMaster-4, SV037ActionMaster-4)

R	S	T	G	N	B1	B2	U	V	W
---	---	---	---	---	----	----	---	---	---

- **Type B Configuration: 7.5 ~ 10 HP** (SV055ActionMaster-2, SV075ActionMaster-2, SV055ActionMaster-4, SV075ActionMaster-4)

R	S	T	G	P	N	B1	B2	U	V	W
---	---	---	---	---	---	----	----	---	---	---

- **Type C Configuration: 15 ~ 30 HP** (SV110ActionMaster-2, SV150ActionMaster-2, SV185ActionMaster-2, SV220ActionMaster-2, SV110ActionMaster-4, SV150ActionMaster-4, SV185ActionMaster-4, SV220ActionMaster-4)

R	S	T	G	P1	P2	N	U	V	W
---	---	---	---	----	----	---	---	---	---

Symbols	Functions
R	AC Line Voltage Input (3 Phase, 200 ~ 230VAC or 380 ~ 460VAC)
S	
T	
G	Earth Ground
P	<i>Positive DC Bus Terminal</i> DB Unit (P-P ⁵) Connection Terminals (DB Unit may be added when more braking duty (More than 30%ED) is required)
P1	External DC Reactor (P1-P2) and DB Unit (P2-P ⁶) Connection Terminals
P2	
N	<i>Negative DC Bus Terminal</i> DB Unit (N-N ⁷) Connection Terminal
B1	Dynamic Braking Resistor (B1-B2) Terminals
B2	
U	3 Phase Power Output Terminals to Motor (3 Phase, 200 ~ 230VAC or 380 ~ 460VAC)
V	
W	

“Suitable for use on a circuit capable of delivering not more than 10,000 rms symmetrical amperes, 240 volts maximum for 230V class models and 480 volts maximum for 460V class models.”

⁶ This P terminal is provided on optional Dynamic Braking Unit.

⁷ This N terminal is provided on optional Dynamic Braking Unit.

1.7.1 Type A Configuration

As standard on the ACtionMaster inverter, this type of configuration has internal dynamic braking resistor of 3% ED. When an application requires more braking duty, an external dynamic braking resistor may be connected instead of the internal resistor.

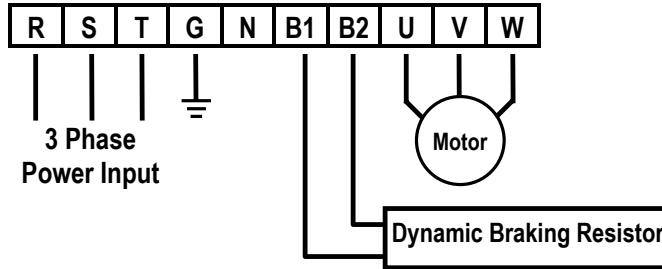

Figure 1 – Type A Dynamic Braking Resistor Installation

1.7.2 Type B Configuration

A Dynamic Braking Resistor or a Dynamic Braking Unit may be added to ACtionMaster series inverters that have a Type B configuration power terminal strip. As standard, this type of configuration has in

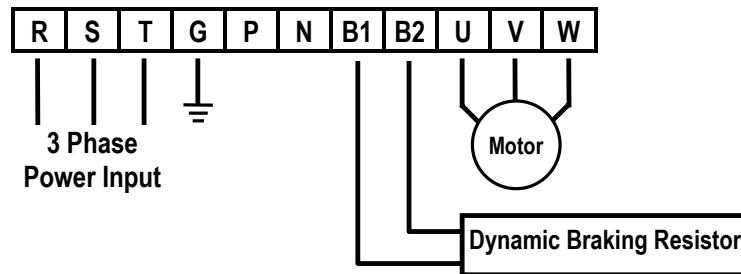

Figure 2 – Type B Dynamic Braking Resistor Installation

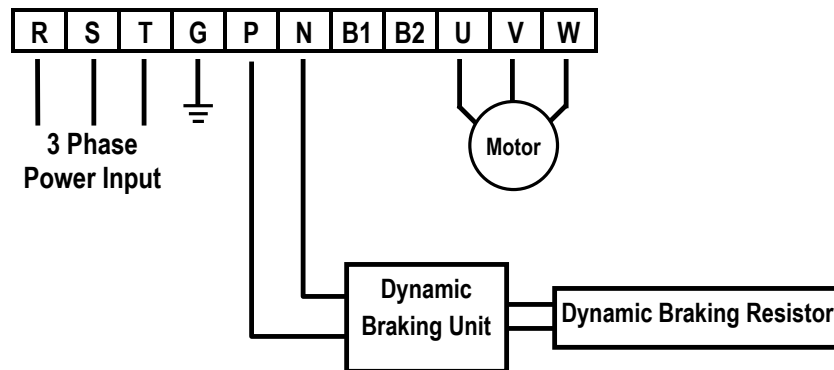



Figure 3 – Type B Additional Dynamic Braking Unit and Resistor Installation

1.7.3 Type C Configuration

A Dynamic Braking Unit or a DC Bus Choke or both of them may be added to ACtionMaster series inverters that have a Type A Configuration power terminal strip.

 **Jumper Between P1 and P2 Must Be Removed in Order to Install a DC Bus Choke.**

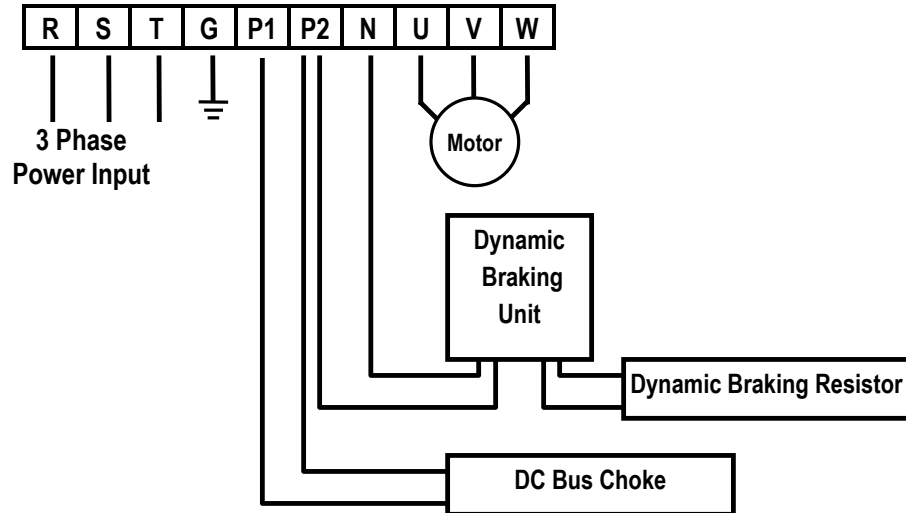

Figure 4 – Type C Dynamic Braking Unit, DC Bus Choke Installation

 **WARNING**

Normal stray capacitance between the inverter chassis and the power devices inside the inverter and AC line can provide a high impedance shock hazard. Refrain from applying power to the inverter if the inverter frame (Power terminal G) is not grounded.

1.7.4 Wiring Power Terminals

■ Wiring Precautions



- The internal circuits of the inverter will be damaged if the incoming power is connected and applied to output terminals (U, V, W).
- Use ring terminals with insulated caps when wiring the input power and motor wiring.
- Do not leave wire fragments inside the inverter. Wire fragments can cause faults, breakdowns, and malfunctions.
- For input and output, use wires with sufficient size to ensure voltage drop of less than 2%.
- Motor torque may drop of operating at low frequencies and a long wire run between inverter and motor.
- When more than one motor is connected to one inverter, total wire length should be less than 500m (1,640ft). Do not use a 3-wire cable for long distances. Due to increased leakage capacitance between wires, over-current protective feature may operate or equipment connected to the output side may malfunction.
- Connect only recommended braking resistor between the B1 and B2 terminals. **Never short B1 and B2 terminals. Shorting terminals may cause internal damage to inverter.**
- The main circuit of the inverter contains high frequency noise, and can hinder communication equipment near the inverter. To reduce noise, install line noise filters on the input side of the inverter.
- Do not use power factor capacitor, surge killers, or RFI filters on the output side of the inverter. Doing so may damage these components.
- Always check whether the LCD and the charge lamp for the power terminal are OFF before wiring terminals. The charge capacitor may hold high-voltage even after the power is disconnected. Use caution to prevent the possibility of personal injury.

■ Grounding



- The inverter is a high switching device, and leakage current may flow. Ground the inverter to avoid electrical shock. Use caution to prevent the possibility of personal injury.
- Connect only to the dedicated ground terminal of the inverter. Do not use the case or the chassis screw for grounding.
- The protective earth conductor must be the first one in being connected and the last one in being disconnected.
- As a minimum, grounding wire should meet the specifications listed below. Grounding wire should be as short as possible and should be connected to the ground point as near as possible to the inverter.

Inverter Capacity	Grounding wire Sizes, AWG (mm ²)	
	200V Class	400VClass
Below 5 HP	12 ((3.5)	14 (2)
7.5 ~ 10 HP	10 (5.5)	12 (3.5)
15 ~ 20 HP	6 (14)	8 (8)
25 ~ 30 HP	4 (22)	6 (14)

Chapter 1 - Installation

■ Wires and Terminal Lugs

Refer to the following table for wires, terminal lugs, and screws used to connect the inverter power input (R, S, T) and output (U, V, W).

Inverter Capacity	Terminal Screw Size	Screw Torque ⁸ (Kgf-cm)/lb-in	Ring Terminals		Wire ⁹				
					mm ²		AWG		
			R,S,T	U,V,W	R,S,T	U,V,W	R,S,T	U,V,W	
200V Class	1 ~ 3 HP	M3.5	15 / 10	2-4	2-4	2	2	14	14
	5 HP	M3.5	15 / 10	2-4	2-4	3.5	3.5	12	12
	7.5 HP	M4	15 / 10	5.5-5	5.5-5	5.5	5.5	10	10
	10 HP	M4	15 / 10	14-5	8-5	14	8	6	8
	15 HP	M5	26 / 18	14-5	14-5	14	14	6	6
	20 HP	M5	26 / 18	22-6	22-6	22	22	4	4
	25 HP	M6	45 / 31	38-8	38-8	30	30	2	2
	30 HP	M6	45 / 31	38-8	38-8	38	30	2	2
400V Class	1 ~ 5 HP	M3.5	15 / 10	2-4	2-4	2	2	14	14
	7.5 HP	M4	15 / 10	5.5-5	5.5-5	3.5	2	12	14
	10 HP	M4	15 / 10	14-5	8-5	3.5	3.5	12	12
	15 HP	M5	26 / 18	14-5	14-5	5.5	5.5	10	10
	20 HP	M5	26 / 18	22-6	22-6	14	8	6	8
	25 HP	M6	45 / 31	38-8	38-8	14	8	6	8
	30 HP	M6	45 / 31	38-8	38-8	22	14	4	6

■ Power and Motor Connection

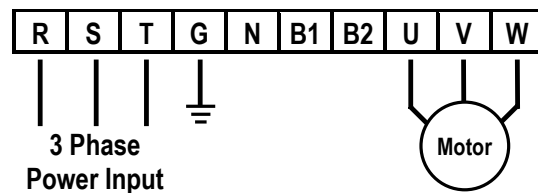

Power supply must be connected to the R, S, and T terminals.

Connecting it to the U, V, and W terminals causes internal damages to the inverter. Arranging the phase sequence is not necessary.



Motor should be connected to the U, V, and W terminals.

If the forward command (FX) is on, the motor should rotate counter clockwise when viewed from the load side of the motor. If the motor rotates in the reverse, switch the U and V terminals.

⁸ Apply the rated torque to terminal screws. Loose screws can cause of short circuit or malfunction. Tightening the screws too much can damage the terminals and cause a short circuit or malfunction.

⁹ Use copper wires only with 600V, 75°C ratings.

1.8 Control Terminals

30A	30C	30B	AXA	AXC
-----	-----	-----	-----	-----

P1	P2	P3	FX	RX	NC	VR	V1	
	JOG	CM	CM	BX	RST	I	FM	5G

Type	Symbol	Name	Description	
Input signal	Starting Contact Function Select	P1, P2, P3	Multi-Function Input 1, 2, 3	Used for Multi-Function Input Terminal. (Factory default is set to "Step Frequency 1, 2, 3".)
		FX	Forward Run Command	Forward Run When Closed and Stopped When Open.
		RX	Reverse Run Command	Reverse Run When Closed and Stopped When Open.
		JOG	Jog Frequency Reference	Runs at Jog Frequency when the Jog Signal is ON. The Direction is set by the FX (or RX) Signal.
		BX	Emergency Stop 	When the BX Signal is ON the Output of the Inverter is Turned Off. When Motor uses an Electrical Brake to Stop, BX is used to Turn Off the Output Signal. When BX Signal is OFF (Not Turned Off by Latching) and FX Signal (or RX Signal) is ON, Motor continues to Run.
		RST	Fault Reset	Used for Fault Reset.
	Analog frequency setting	CM	Sequence Common	Common Terminal for Contact Inputs.
		NC	-	Not Used.
		VR	Frequency Setting Power (+12V)	Used as Power for Analog Frequency Setting. Maximum Output is +12V, 100mA.
		V1	Frequency Reference (Voltage)	Used for 0-10V Input Frequency Reference. Input Resistance is 20 K Ω
I		Frequency Reference (Current)	Used for 4-20mA Input Frequency Reference. Input Resistance is 250 Ω	
Output signal	Analog	5G	Frequency Setting Common Terminal	Common Terminal for Analog Frequency Reference Signal and FM (Frequency Meter).
		FM	Analog Output (0~10V) (For External Monitoring)	Outputs One of the Following: Output Frequency, Output Current, Output Voltage, DC Link Voltage and Torque. Default is set to Output Frequency. Maximum Output Voltage and Output Current are 0-12V and 1mA.
	Contact	30A 30C 30B	Fault Contact Output	Activates when Protective Function is Operating. AC250V, 1A or less; DC30V, 1A or less. Fault: 30A-30C Closed (30B-30C Open) Normal: 30B-30C Closed (30A-30C Open)
AXA, AXC		Multi-Function Output Relay	Use After Defining Multi-Function Output Terminal. AC250V, 1A or less; DC30V, 1A or less.	
Comm.	CN3	Communication Port	Keypad Connection Port.	

Tightening Torque: 5.2 lb-in maximum.

1.8.1 Wiring Control Terminals

■ **Wiring Precautions**

- CM and 5G terminals are insulated to each other. Do not connect these terminals with each other and do not connect these terminals to the power ground.
- Use shielded wires or twisted wires for control circuit wiring, and separate these wires from the main power circuits and other high voltage circuits.

■ **Control Circuit Terminal**

- The control input terminal of the control circuit is ON when the current flows out of the terminal, as shown in the following illustration. CM terminal is the common terminal for the contact input signals.

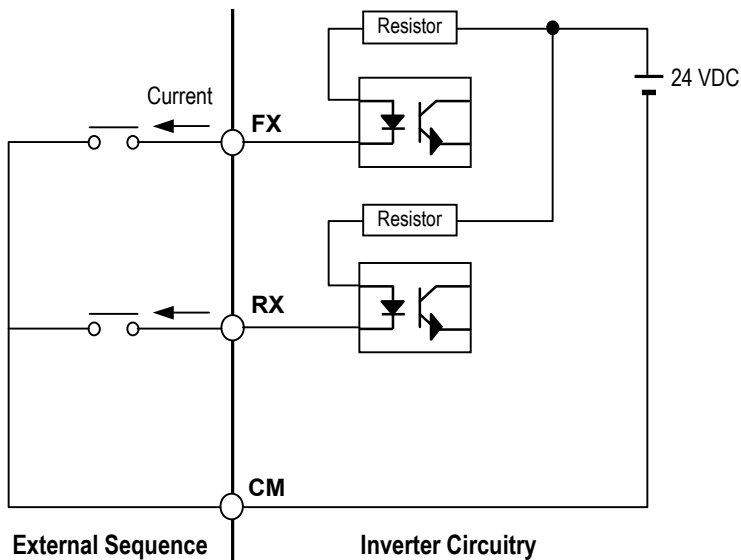

 **CAUTION**

Do not apply voltage to any control input terminals (FX, RX, P1, P2, P3, JOG, BX, RST, CM).

1.8.2 Keypad Connection

Connect keypad to the keypad connector as illustrated below. The LCD output will not be displayed on the keypad if the keypad is not connected properly.

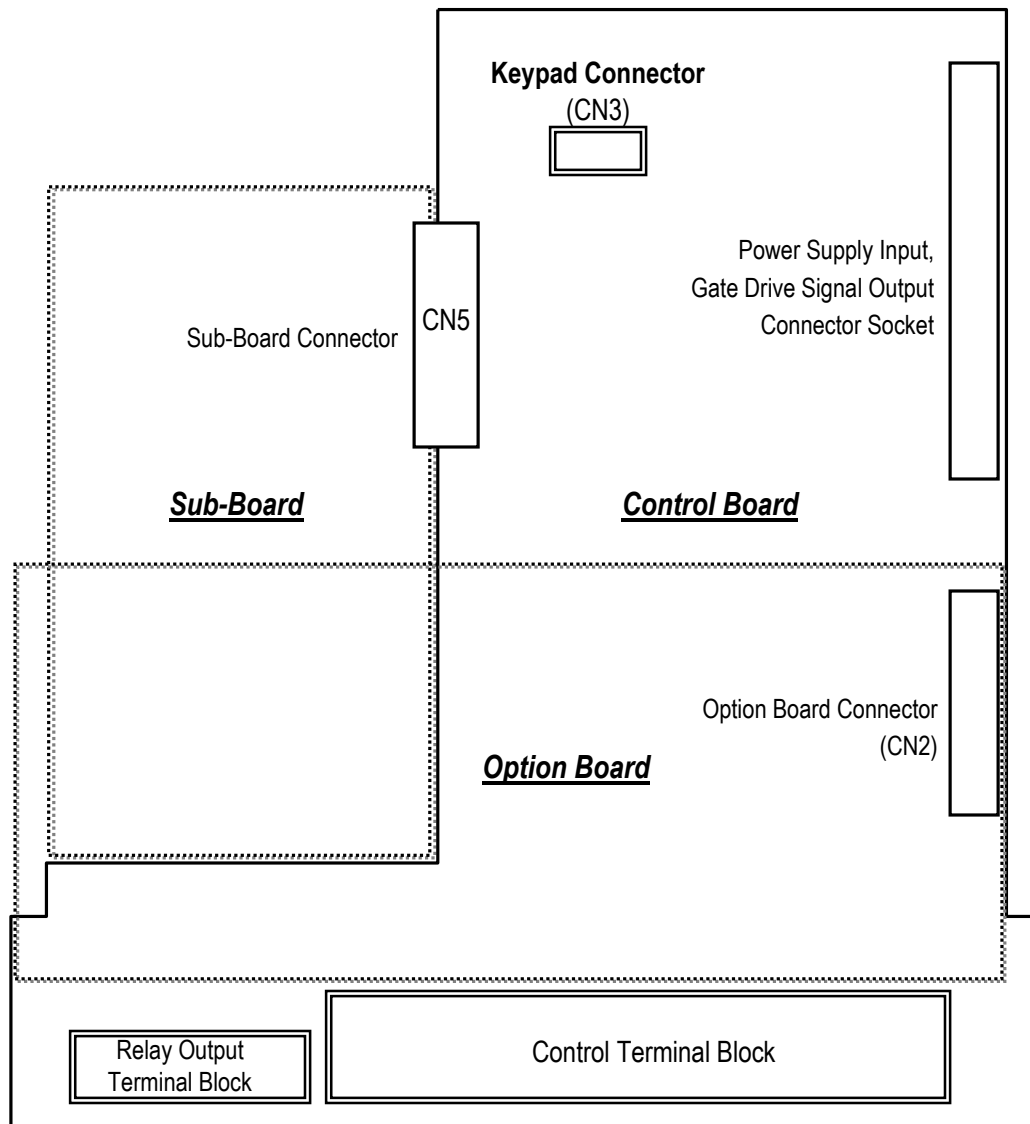

Notes:

CHAPTER 2 - OPERATION

The ACtionMaster series inverter has seven parameter groups separated according to their applications as indicated in the following table.

The ACtionMaster series inverter provides two kinds of keypad. One is of 32-character alphanumeric LCD keypad and the other is of 7-Segment LED keypad.

2.1 Parameter Groups

Parameter Group	LCD Keypad (Upper left Corner)	7-segment Keypad (LED is lit)	Description
Drive Group	DRV	'DRV' LED	Command Frequency, Accel/Decel Time etc. Basic Parameters
Function 1 Group	FU1	'FU1' LED	Max. Frequency, Amount of Torque Boost etc. Basic Related Parameters
Function 2 Group	FU2	'FU2' LED	Frequency Jumps, Max./Min. Frequency Limit etc. Basic Application Related Parameters
Input / Output Group	I/O	'I/O' LED	Multi-Function Terminal Setting, Auto Operation etc. Parameters needed for Sequence Operation
Sub-Board Group	EXT	'EXT' LED	Displayed when Sub-Board is Installed.
Option Group	COM	'I/O' + 'EXT' LED	Displayed when Option Board is Installed.
Application Group	APP	'FU2' + 'I/O' + 'EXT' LED	Traverse, MMC (Multi-Motor Control), Draw etc. Application Related Parameters

Refer to the function descriptions in Chapter 6 for detailed description of each group.

2.2 LCD Keypad

LCD keypad can display up to 32 alphanumeric characters, and various settings can be checked directly from the display. The following is an illustration of the keypad.

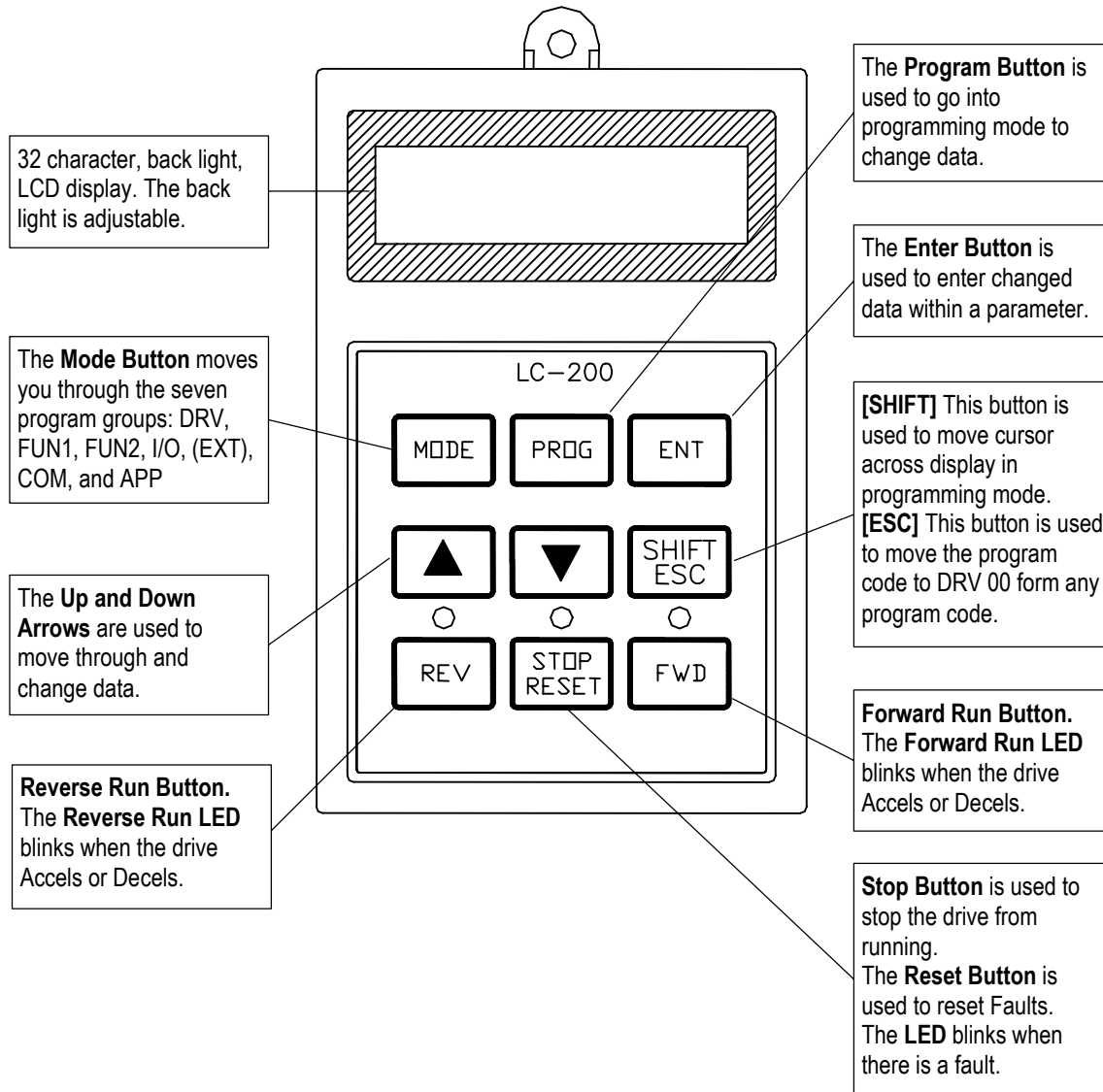

2.2.1 LCD Keypad Display

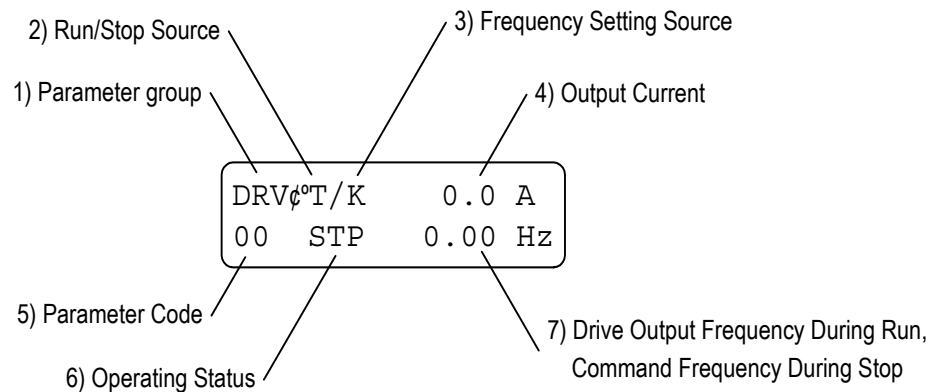

Displays	Description
1) Parameter Group	Displays the parameter group. There are DRV, FU1, FU2, I/O, EXT, COM, APP groups.
2) Run/Stop Source	Displays the source of motor Run and Stop K : Run/Stop using FWD, REV buttons on keypad T : Run/Stop using control terminal input FX, RX O : Run/Stop via option board
3) Frequency Setting Source	Displays the source of command frequency setting K : Frequency setting using keypad V : Frequency setting using V1 (0 ~10V) or V1 + I terminal I : Frequency setting using I (4 ~ 20mA) terminal U : Up terminal input when Up/Down operation is selected D : Down terminal input when Up/Down operation is selected S : Stop status when Up/Down operation is selected O : Frequency setting via Option board X : Frequency setting via Sub board J : Jog terminal input 1 ~ 8 : Step frequency operation <i>* During Auto operation, 2) and 3) display the 'sequence number/step'.</i>
4) Output Current	Displays the Output Current during operation.
5) Parameter Code	Displays the code of a group. Use the ▲ (Up), ▼ (Down) key to move through 0~99 codes.
6) Operating Status	Displays the operation information. STP : Stop Status FWD : During Forward operation REV : During Reverse operation DCB : During DC Braking LOP : Loss of Reference from Option Board (DPRAM fault) LOR : Loss of Reference from Option Board (Communication network fault) LOV : Loss of Analog Frequency Reference (V1: 0~10V) LOI : Loss of Analog Frequency Reference (I: 4~20mA) LOS : Loss of Reference from Sub-Board
7) Drive Output Frequency Command Frequency	Displays the Output Frequency during run. Displays the Command Frequency during stop.

2.2.2 Procedure for Setting Data (LCD Keypad)

1. Press **[MODE]** key until the desired parameter group is displayed.
2. Press **[▲]** or **[▼]** keys to move to the desired parameter code. If you know the desired parameter code, you can set the code number of each parameter group in “Jump code”, except DRV group.
3. Press **[PROG]** key to go into the programming mode, the cursor starts blinking.
4. Press **[SHIFT/ESC]** key to move the cursor to the desired digit.
5. Press **[▲]** or **[▼]** keys to change the data.
6. Press **[ENT]** key to enter the data. The cursor stops blinking.

■ **Note:** Data cannot be changed when:

- 1) The parameter is not adjustable during the inverter is running. (Refer to the function table in Chapter 5), or,
- 2) Parameter Lock function is activated in FU2-94 [Parameter Lock].

2.2.3 Parameter Navigation (LCD Keypad)

The parameter group moves directly to DRV group by pressing [SHIFT/ESC] key in any parameter code.

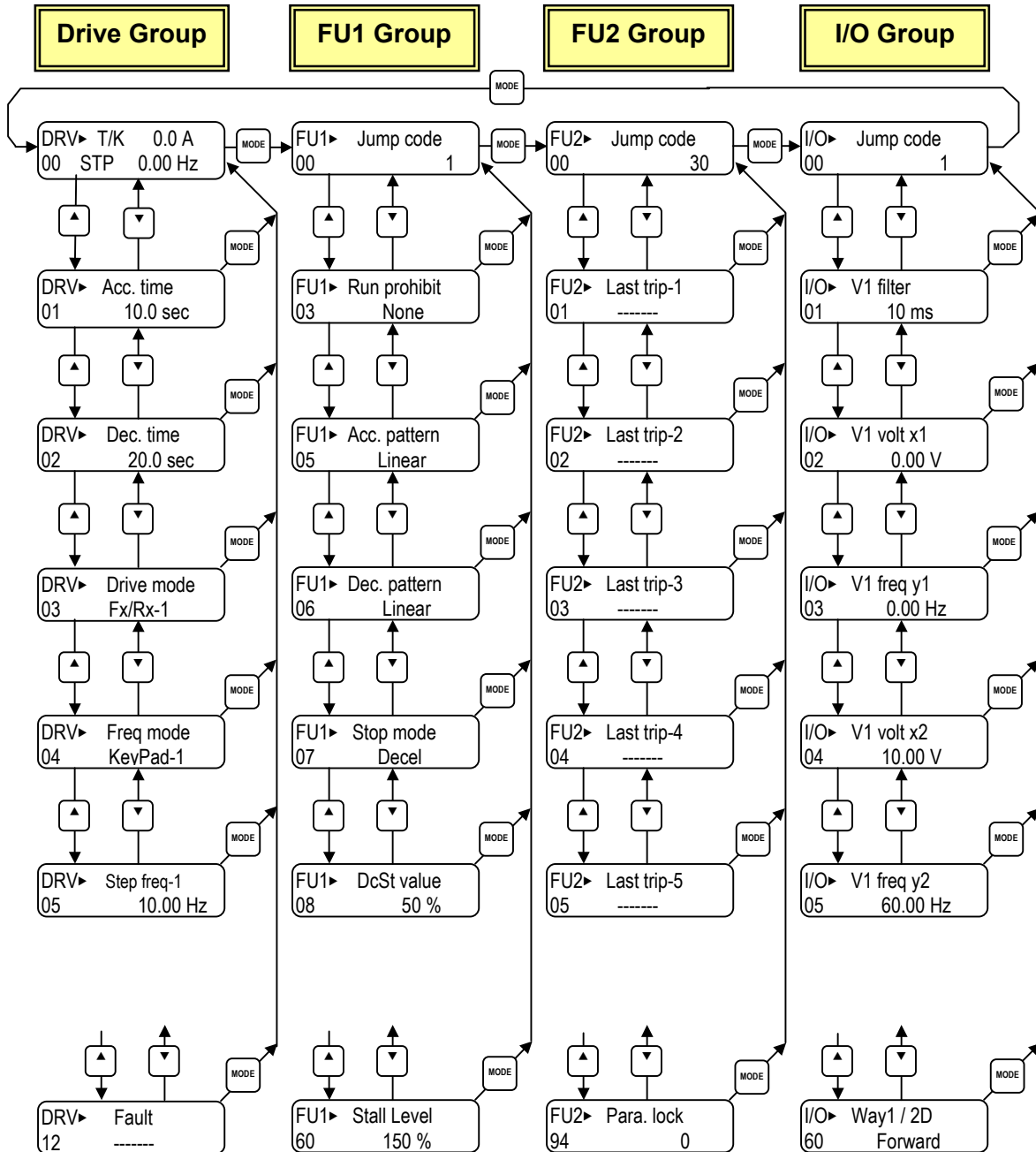

2.3 7-Segment Keypad

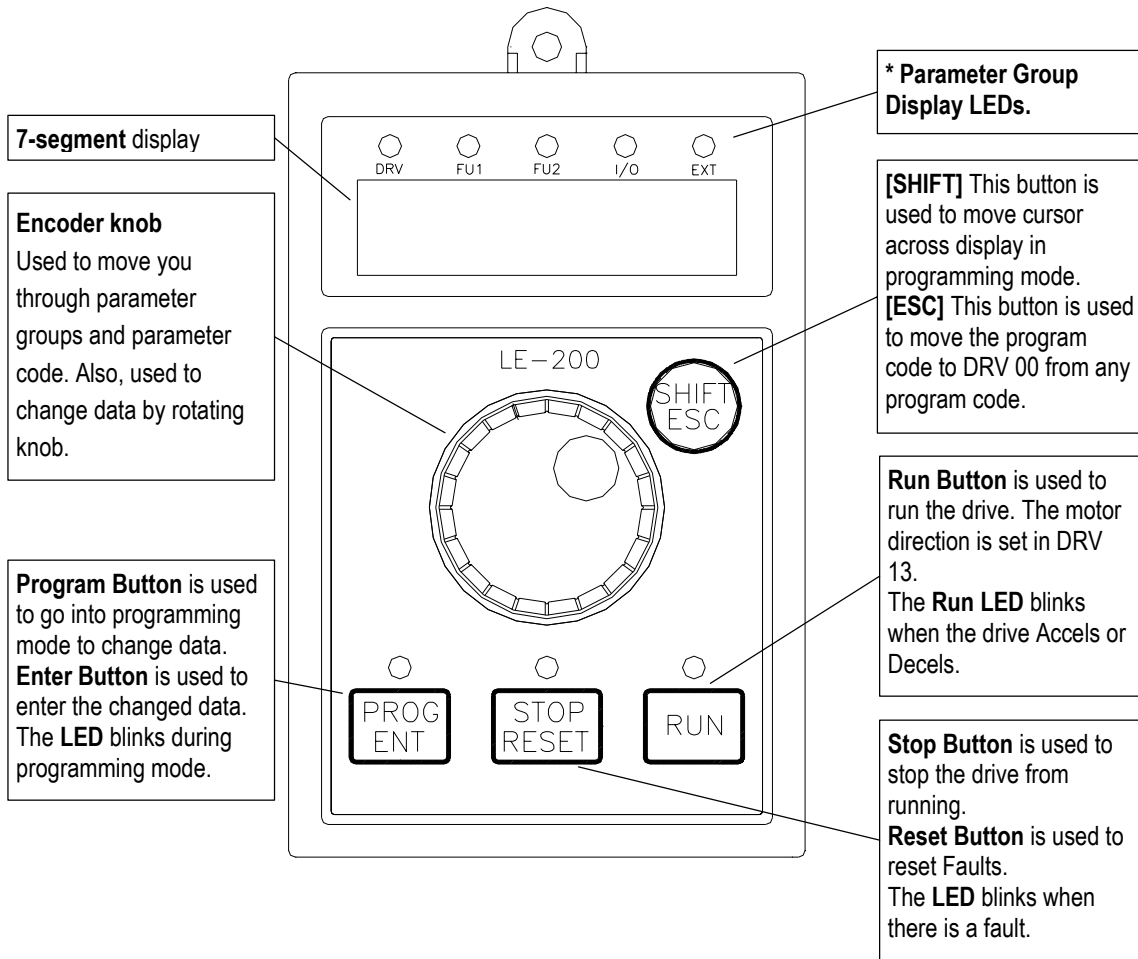

* **Parameter Group Display LEDs** – When parameter code is located on DRV 20, DRV 21, DRV 22 and DRV 23, respectively, by rotating the encoder knob, the parameter group display LEDs of DRV, FUN1, FUN2, I/O, EXT blink.

LED	Parameter Group	Description
DRV	Drive Group	Lit in Drive group.
FU1	FUNCTION 1 Group	Blinks when the parameter code is located on DRV 20 [FUN1]. Lit when FUNCTION 1 group is selected.
FU2	FUNCTION 2 Group	Blinks when the parameter code is located on DRV 21 [FUN2]. Lit when FUNCTION 2 group is selected.
I/O	Input/Output Group	Blinks when the parameter code is located on DRV 22 [I/O]. Lit when Input/Output group is selected
EXT	Sub-Board Group	Blinks when the parameter code is located on DRV 23 [EXT]. Lit when Sub-Board group is selected. This group appears only when a Sub-Board is installed.
I/O + EXT	Option Group	Blinks when the parameter code is located on DRV 24 [EXT]. Lit when Option group is selected. This group appears only when an Option Board is installed.
FU2 + I/O + EXT	Application Group	Blinks when the parameter code is located on DRV 25 [FUN2].

2.3.1 7-Segment Keypad Display

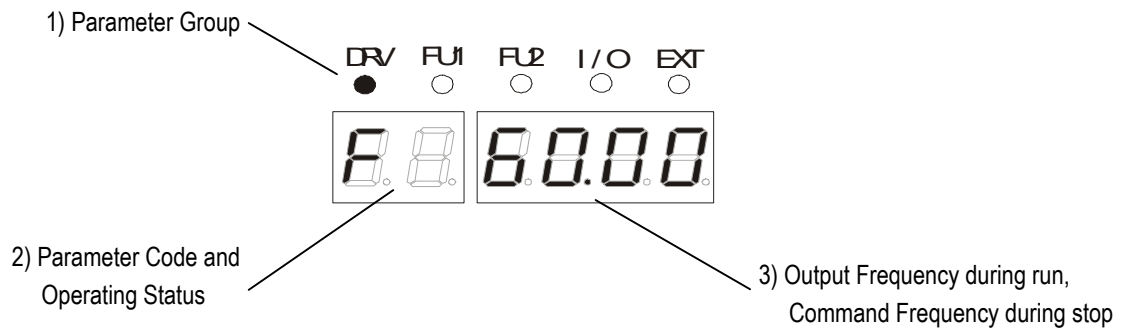

Display	Description
1) Parameter Group	Displays the parameter groups of DRV, FU1, FU2, I/O, EXT, COM, APP groups. Each LED is lit when its parameter group is selected and blinks when the parameter code is located on DRV 20, DRV 21, DRV 22, DRV 23, DRV 24, and DRV 25.
2) Parameter Code and Operating Status	Displays the code of a group. Rotate the encoder knob to move through 0 ~ 99 codes. Displays the operation information. [First digit] F: Forward operation r: Reverse operation [Second digit] d: DC Braking J: Jog Terminal Input 1~8: Step Frequency Input (Displays the Step of the Auto operation) [Two digits] - when the reference is lost. LP: Loss of Reference from the Option Board (DPRAM fault) Lr: Loss of Reference from the Option Board (Communication network fault) Lv: Loss of Analog Frequency Reference (V1: 0~10V) Ll: Loss of Analog Frequency Reference (I: 4~20mA) LX: Loss of Reference from the Sub-Board
3) Output Frequency, Command Frequency	Displays the Output Frequency during run. Displays the Command Frequency during stop.

2.3.2 Procedure for Setting Data (7-Segment Keypad)

■ In DRV Group:

1. Rotate the encoder knob until the desired parameter code is displayed.
2. Press **[PROG/ENT]** key to go into the programming mode, then the display blinks.
3. Press **[SHIFT/ESC]** key to move the cursor to the desired digit.
4. Rotate the encoder knob to change the data.
5. Press **[PROG/ENT]** key to enter the changed data.

■ In FUN1 Group:

1. Rotate the encoder knob until parameter code '20' is displayed in drive group.
2. Press **[PROG/ENT]** key to go into the FUN1 group.
3. Rotate the encoder knob until the desired parameter code is displayed.
4. Press **[PROG/ENT]** key to go into the programming mode, then the display blinks.
5. Press **[SHIFT/ESC]** key to move the cursor to the desired digit.
6. Rotate the encoder knob to change the data.
7. Press **[PROG/ENT]** key to enter the changed data.

■ In FUN2 Group:

1. Rotate the encoder knob until parameter code '21' is displayed in drive group.
2. Go to step 2 of 'In FUN1 Group' above, and follow the rest procedure.

■ In I/O Group:

1. Rotate the encoder knob until parameter code '22' is displayed in drive group.
2. Go to step 2 of 'In FUN1 Group' above, and follow the rest procedure.

2.3.3 Parameter Navigation (7-Segment Keypad)

The parameter group moves directly to DRV group by pressing [SHIFT/ESC] key in any parameter code.

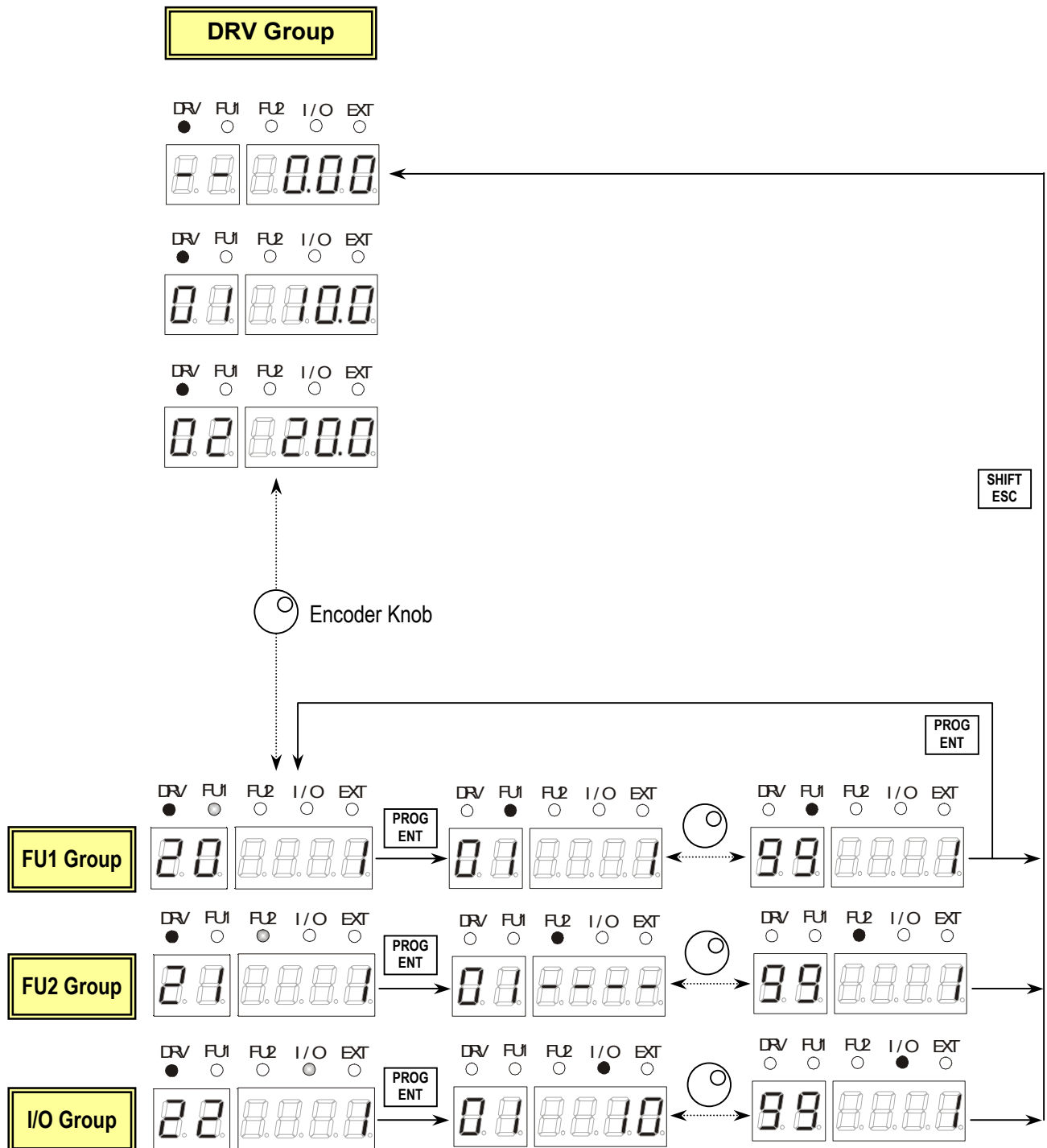

2.4 Operation Method

The ACtionMaster has several operation methods as shown below.

Operation Method	Function	Function Setting
Operation using Keypad	Run/Stop command and frequency are set only through the keypad.	DRV 03: Keypad DRV 04: Keypad-1 or -2
Operation using Control Terminals	Closing FX or RX terminal performs Run/Stop. Frequency reference is set through V1 or I or V1+I terminal.	DRV 03: Fx/Rx-1 or -2 DRV 04: V1 or I or V1+I
Operation using both Keypad and Control Terminals	Run/Stop is performed by the keypad. Frequency reference is set through the V1 or I or V1+I terminal.	DRV 03: Keypad-1 or -2 DRV 04: V1 or I or V1+I
	Closing FX or RX terminal performs Run/Stop. Frequency reference is set through the keypad.	DRV 03: Fx/Rx-1 or -2 DRV 04: Keypad-1 or -2
Operation using Option Boards	Operation using option board. The ACtionMaster has five option boards and three sub-boards. Option Boards: RS485, Device-Net, F-Net, ProfiBus and ModBus Sub-Boards: Sub-A Board, Sub-B Board, Sub-C Board and Sub-D Board.	Please refer to 'Chapter 7 - Options' for more information.

Notes:

CHAPTER 3 - QUICK-START PROCEDURES

These Quick-Start Up instructions are for those applications where:

- The user wants to get the ACtionMaster inverter started quickly
- The factory-preset values are suitable for the user application

The factory-preset values are shown on the 'Chapter 4 - Parameter List'. The ACtionMaster inverter is configured to operate a motor at 60Hz (base frequency). If the application requires coordinated control with other controllers, it is recommended the user become familiar with all parameters and features of the inverter before applying AC power.

1. Mounting the inverter (mount the inverter as described in '1.3 Mounting')

- Install in a clean, dry location
- Allow a sufficient clearance around top and sides of inverter
- The ambient temperature should not exceed 40°C (104°F)
- If two or more inverters are installed in an enclosure, add additional cooling

2. Wiring the inverter (connect wiring as described in '1.7 Power Terminals')

- AC power should be turned OFF
- Verify the AC power matches the nameplate voltage
- Remove the screw on the bottom front cover of the inverter for terminal board access (For terminal board access on 15~ 30HP inverters you must disconnect the keypad cable from the inverter and fully removed the cover)

3.1 Operation using Keypad

	LCD Display	7-Segment Display
1. Apply AC power.		 The DRV LED is ON.
2. LCD: Press [▲] key three times. 7-Seg: Rotate the encoder knob until '03' is displayed.		 The DRV LED is turned ON.
3. LCD: Press [PROG] key. 7-Seg: Press [PROG/ENT] key.		 The PROG/ENT LED turned ON.
4. LCD: Press [▼] key one time. 7-Seg: Rotate the encoder knob left.		 The PROG/ENT LED is turned ON.
5. LCD: Press [PROG] key. 7-Seg: Press [PROG/ENT] key.		
6. Press [PROG/ENT] key.		
7. LCD: Press [PROG] key. 7-Seg: Press [PROG/ENT] key.		 The PROG/ENT LED is turned ON.
8. LCD: Press [SHIFT/ESC] key and press [▲] key to increase the command frequency. 7-Seg: Rotate the encoder knob right to change the command frequency. The changing digit moves by pressing the [SHIFT/ESC] key.		 The PROG/ENT LED is turned ON.
9. LCD: Press [ENT] key to save the data. 7-Seg: Press [PROG/ENT] key to save the data.		
10. LCD: Press [FWD] or [REV] key to start motor. 7-Seg: Press [RUN] key to start motor.	The STOP/RESET LED starts blinking.	The RUN LED starts blinking. To change the motor running direction, change DRV 13 to '1'.
11. Press [STOP/RESET] key to stop motor.	The FWD or REV LED starts blinking.	The STOP/RESET LED starts blinking.

3.2 Operation using Control Terminals

1. Install a potentiometer on terminals V1, VR, 5G and connect wiring as shown below.

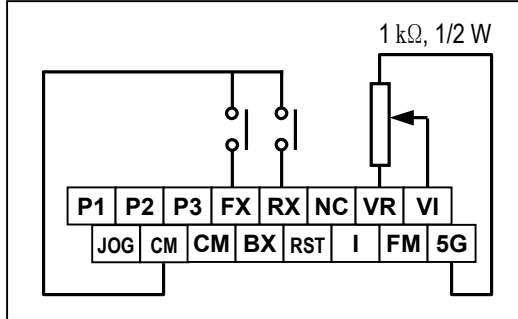

2. Apply AC power.

DRV▶T/K 0.0 A
00 STP 0.00Hz

F 0.00

The DRV LED is ON.

3. Confirm that the DRV 03 is set at 'Fx/Rx-1'.

DRV▶ Drive mode
03 Fx/Rx-1

03 1

4. **LCD:** Press [▲] key to move DRV 04.
7-Seg: Rotate encoder knob until '04' is displayed.

DRV▶ Freq mode
04 Keypad-1

04 0

5. **LCD:** Press [PROG] key.
7-Seg: Press [PROG/ENT] key.

DRV▶ Freq mode
04 Keypad-1

04 0

The PROG/ENT LED is turned ON.

6. **LCD:** Press [▲] key and set at 'V1'.
7-Seg: Rotate encoder knob and set at '2'.

DRV▶ Freq mode
04 V1

04 2

The PROG/ENT LED is turned ON.

7. **LCD:** Press [ENT] key.
7-Seg: Press [PROG/ENT] key.

DRV▶ Freq mode
04 V1

04 2

The PROG/ENT LED is turned OFF.

8. Press [SHIFT/ESC] key.

DRV▶T/V 0.0 A
00 STP 0.00Hz

F 0.00

9. Set the frequency by rotating the potentiometer.

DRV▶T/V 0.0 A
00 STP 60.00Hz

F 60.00

10. Close the FX or RX contact to run the motor.

The FWD or REV LED starts blinking.

The RUN LED starts blinking.

11. Open the FX or RX contact to stop the motor.

The STOP/RESET LED starts blinking.

The STOP/RESET LED starts blinking.

3.3 Operation using Keypad and Control Terminals

3.3.1 Frequency set by External Source and Run/Stop by Keypad

1. Install a potentiometer on terminals V1, VR, 5G and connect wiring as shown below left.
When a '4 to 20mA' current source is used as the frequency reference, use terminals I and 5G as shown below right.

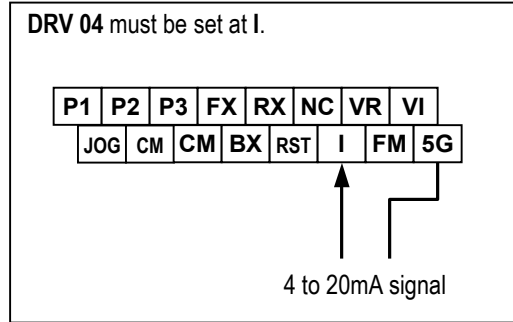
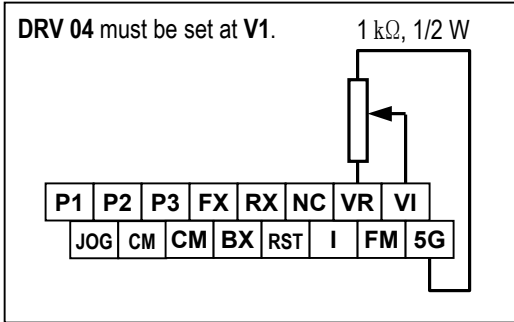

2. Apply AC power.

DRV▶T/K	0.0 A
00 STP	0.00Hz



The DRV LED is ON.

3. LCD: Press [▲] key to move DRV 03.
7-Seg: Rotate encoder knob until '03' is displayed.

DRV▶ Drive mode	
03 Fx/Rx-1	

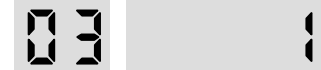

4. LCD: Press [PROG] key.
7-Seg: Press [PROG/ENT] key.

DRV▶ Drive mode	
03 Fx/Rx-1	

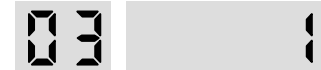

The PROG/ENT LED is turned ON.

5. LCD: Press [▲] key one time.
7-Seg: Rotate encoder knob and set at '0'.

DRV▶ Drive mode	
03 Keypad	



The PROG/ENT LED is turned ON.

6. LCD: Press [ENT] key.
7-Seg: Press [PROG/ENT] key.

DRV▶ Drive mode	
03 Keypad	



The PROG/ENT LED is turned OFF.

7. Confirm that the DRV 04 is set at 'V1'.

DRV▶ Freq mode	
04 V1	



The PROG/ENT LED is turned ON.

8. Press [SHIFT/ESC] key.
Set the frequency by rotating the potentiometer.

DRV▶T/V	0.0 A
00 STP	60.00Hz



9. LCD: Press [FWD] or [REV] key.
7-Seg: Press [RUN] key.

The FWD or REV LED starts blinking.

The RUN LED starts blinking.
To change the motor running direction, change DRV 13 to '1'.

3.3.2 Frequency set by Keypad and Run/Stop by External Source.

1. Connect wiring as shown below.

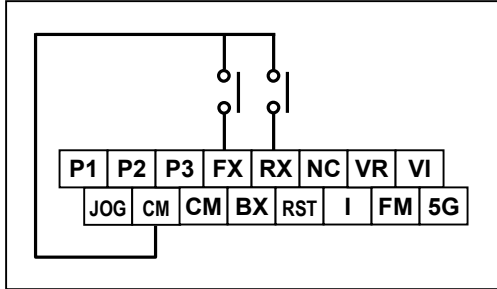

LCD Display

7-Segment Display

2. Apply AC power.

DRV▶T/K 0.0 A
00 STP 0.00Hz

F 0.00

The DRV LED is ON.

3. Confirm that the DRV 03 is set at 'Fx/Rx-1'.

DRV▶ Drive mode
03 Fx/Rx-1

03 1

4. Confirm that the DRV 04 is set at 'Keypad-1'.

DRV▶ Freq mode
04 Keypad-1

04 0

5. Press [SHIFT/ESC] key.

DRV▶T/K 0.0 A
00 STP 0.00Hz

F 0.00

6. LCD: Press [PROG] key.
7-Seg: Press [PROG/ENT] key.

DRV▶ Cmd. freq
00 0.00Hz

00 00.00

The PROG/ENT LED is turned ON.

7. LCD: Set the frequency using [SHIFT/ESC] and [▲] key.
7-Seg: Set the frequency by rotating the encoder knob.

DRV▶ Cmd. freq
00 60.00Hz

00 60.00

The PROG/ENT LED is turned ON.

8. LCD: Press [ENT] key to save the data.
7-Seg: Press [PROG/ENT] key to save the data.

DRV▶T/V 0.0 A
00 STP 60.00Hz

F 60.00

9. Close the FX or RX contact to run the motor.

The FWD or REV LED starts blinking. The RUN LED starts blinking.

10. Open the FX or RX contact to stop the motor.

The STOP/RESET LED starts blinking. The STOP/RESET LED starts blinking.

CHAPTER 4 - VARIOUS FUNCTION SETTING & DESCRIPTION

4.1 Function Setting

4.1.1 Basic function parameter setting

It is the basic function setting. All settings are factory defaults unless users make change. It is recommended to use factory setting value unless the parameter change is necessary.

1) Common parameter setting

The following table shows common parameter setting that should be checked before use but making change does not affect inverter control type.

Parameter Name	Code	Description
Rated Motor Selection	FU2-30	Select motor and voltage rating suitable to the desired inverter
Parameters related to motor	FU2-31 ~ 36	Basic parameter value setting when selecting the motor rating. Note) If there is any discrepancy between parameter preset value and the actual motor parameter value, change the parameter value according to the actual motor.
Drive Mode	DRV-3	Operation via Keypad, Fx/Rx-1, Fx/Rx-2 setting enable
Frequency or Torque Mode	DRV-4	Frequency/Torque setting parameter It automatically changes to torque mode when FU2 39-[Control mode] is set to Sensorless_T, Vector_TRQ
Accel/Decel time setting	DRV-1, DRV-2	Setting Accel/Decel time enable

2) V/f control

FU2-39 [Control mode] is set to 0 (V/F) as factory setting. Operation via V/F control can be performed after common parameter settings are done and the followings are set.

Parameter Name	Code	Description
Starting freq.	FU1-22	Setting frequency to start the motor
Torque boost	FU1-26	Manual or Auto torque boost settable in this parameter
Torque boost value in FWD/REV	FU1-27, FU1-28	If FU1-26 [torque boost] is set to manual, user sets the desired value and the direction in code FU1-27 and 28.

3) V/F + PG control

If FU2-39 [control mode] is set to V/F with PG (encoder) feedback using SUB-B or SUB-D boards, the control type is automatically changed to **V/F + PG**. The following parameters should be set accordingly to enable PG feedback using SUB-B or SUB-D boards.

Parameter Name	Code	Description
Usage of Pulse Input Signal	EXT-12	Defines the use of pulse input signal with SUB-B or SUB-D mounted. This parameter should be set to 1 {Feedback}.
Pulse Input Signal Selection	EXT-15	Three types of input signal settable; (A+B), A, -(A+B)
Encoder Pulse Number	EXT-16	Defines the number of encoders of the motor.
P-Gain for 'Sub-B' I-Gain for 'Sub-B'	EXT-22, EXT-23	PI gains for PI controller during PG operation
Slip Frequency for 'Sub-B' Board	EXT-24	Setting as a percent of FU2-32 [Rated Motor Slip]

4) Slip compensation

operation is done via Slip compensation if FU2-39 is set to 1 {Slip compen}. This control keeps motor speed constant regardless of load change.

5) Auto-tuning of motor constant

This parameter enables auto-tuning of the motor constants. If set to 1 {All mode}, tuning type varies according to what control mode is set in [FU2-39]. Auto-tuning can be done in two ways – one is motor non-rotation mode, the other is motor rotation mode.

- ① **Auto-tuning by non-rotation mode: Rs+Lsigma**
- ② **Auto-tuning by rotation mode : All, Enc Test, Tr**

Before performing Auto-tuning, set motor rating, motor parameter in common setting and select the desired control mode in FU2-39 [control mode selection]. However, when auto-tuning parameters related to encoder, detail functions settings of vector control should be pre-defined. If **Enc Test, Tr and control mode are set to vector control**, Sub-B or Sub-D board should be mounted.

Parameter Name	Code	Description
Auto-tuning	FU2-40	No, All, Rs+Lsigma, Enc Test, Tr
Parameter value display	FU2-34, FU2-41 ~ 44	Tuned value monitoring (no-load current, stator/rotor resistance, leakage inductance, rotor filter time constant)

FU2-40	Description
No	Motor constants calculation disabled
All	All constants can be measured in this code but different constants are tuned according to control mode type; For V/F, Slip compen , Sensorless_S, Sensorless_T: (No-load current, stator resistance, leakage inductance, stator inductance available) Note) Only no-load current can be calculated during V/F and Slip compensation. For Vector_SPD, Vector_T: No-load current, stator resistance, leakage inductance, stator inductance, encoder test, rotor filter time constant
Rs+Lsigma	Calculate stator resistance, leakage inductance
Enc Test	Calculate the encoder status
Tr	Calculate Rotor filter time constant

6) Sensorless vector control

Set FU2-39 to 2 {Sensorless_S} or 3 {Sensorless_T} to enable Sensorless vector control. It is strongly recommended to perform Auto-tuning for Sensorless before starting Sensorless control in order to maximize performance. Two types of Sensorless vector control are available; Sensorless_S or Sensorless_T.

Parameter Name	Code	Description
Control mode selection	FU2-39	Select Sensorless_S or Sensorless_T
P, I gain for sensorless control	FU2-45, FU2-46	Setting gain for Sensorless_S control
Starting freq	FU1-22	Starting freq of the motor

7) Vector control

Set FU2-39 to 4 {Vector_SPD} or 5{Vector_TRQ} to enable Vector control. Encoder should be installed to the motor with Sub-B or Sub-D boards in the inverter to start this control.

Parameter Name	Code	Description
Usage of Pulse Input Signal	EXT-12	Defines the method of pulse input with SUB-B or SUB-D boards mounted. Vector control setting is valid only after this parameter is set to 1 {Feed-back}.
Pulse Input Signal Selection	EXT-15	3 types of pulse input : (A+B), A, -(A+B)
Encoder Pulse Number	EXT-16	Enter the pulse number of encoder in the motor.

Before selecting Vector control mode, encoder setting should be done as indicated above. If the parameter value of actual motor is set in common setting, execute Auto-tuning before selecting vector control mode.

Parameter Name	Code	Description
Control Mode Selection	FU2-39	Select Vector_SPD or Vector_TRQ
Forward/ Reverse Torque Limit	EXT-27, EXT-28	Setting the FWD/REV limit to the torque current
P-Gain/ I-Gain for (Sensored) Vector_SPD	EXT-25, EXT-26	Setting P/I Gain for Vector_SPD control
Speed Limit setting	EXT-50, EXT-51 EXT-52, EXT-53	Setting speed limit for Vector_TRQ
Zero Speed Detection Level/ Bandwidth	EXT-54, EXT-55	Setting on/off of Multi-function output terminal relay when the motor speed reaches to 0.
Torque Detection Level/Bandwidth	EXT-56, EXT-57	Detect certain level/bandwidth of Torque

4.1.2 Advanced function 1 setting

SV-ACtionMaster inverter features advanced function parameters to maximize efficiency and performance of the motor. It is recommended to use as factory setting unless parameter value change is necessary.

1) V/F control

Parameter Name	Code	Description
V/F Pattern	FU1-29	Use it according to load characteristics. If User V/F is selected, User can select the optimum output V/F characteristic for the application and load characteristics in [FU1-30]~[FU1-37]
Dwell operation	FU2-07 FU2-08	Used to output torque in an intended direction. Inverter stops acceleration for the preset [FU2-08] Dwell time while running at Dwell frequency [FU2-07] and starts acceleration at commanded frequency. Setting [FU2-08] Dwell time to 0 disable the Dwell operation.
Frequency jump	FU2-10 FU2-11~16	When it is desired to avoid resonance attributable to the natural frequency of a mechanical system, these parameters allow resonant frequencies to be jumped. Up to three areas can be set, with the jump frequencies set to either the top or bottom point of each area. To enable the function, set [FU2-10] to 'Yes' and set the value in [FU2-11]~[FU2-16].
S-shaped curve Accel/Decel pattern	FU2-17/ FU2-18	This pattern has an effect on the prevention of cargo collapse on conveyor etc and reduction in an acceleration/ deceleration shock.

2) Sensorless vector control

Related parameters for starting during **Sensorless vector control** when FU2-39 [Control Mode Selection] is set to 2 {Sensorless_S}.

Status	Code	Description
When starting	FU1-14	Setting pre-excitation time
	I/O12~14 EXT2~4	Multi-function input terminal P1- P6 define

3) Vector control [Vector_SPD, Vector_TRQ]

Related parameters for starting/ running/ stopping during **Vector control** when FU2-39 [Control Mode Selection] is set to 4 {Vector_SPD}.

Status	Code	Description
When starting	FU1-14	Setting pre-excitation time
	I/O12~14 EXT2~4	Multi-function input terminal P1- P6 define
Pre-excitation current	FU1-16	Setting the Pre-excitation current
When stopping	FU1-15	Setting hold time at a stop
	FU1-7	Stopping method selection

This parameter can limit the over-speeding (motor running above limit level) of the motor when FU2-39[Control mode] is set to 5 {Vector_TRQ}.

Parameter Name	Code	Description
Speed limit level / bias / gain	EXT-50 ~ EXT-53	Function to limit the speed and change reference torque value according to speed

4) Parameters to view motor and inverter status

Parameter Name	Code	Description
Output current/ motor speed	DRV 8 ~ 9	Display output current and motor rpm
DC link voltage	DRV 10	Display DC link voltage
User display selection (Voltage and watt)	DRV11 FU2-73	Either output voltage or power selected in FU2-73 is displayed in DRV11.
Reference/ Feedback frequency display	DRV15	Display Reference/ Feedback frequency display
Fault display	DRV12	Display the current inverter fault

5) Parameter initialize

Parameter Name	Code	Description
Software version	FU2-79	Display the inverter software version
Parameter Read/Write/Initialize/Write protection	FU2-91 FU2-92 FU2-93 FU2-94	[FU2-91], [FU2-92]: Copying parameters from other inverter enabled [FU2-93]: Initializing parameters to factory setting values [FU2-94] : Parameter write disabled

6) Protection & fault detection level setting

Parameter Name	Code	Description
Electronic thermal	FU1-50 FU1-51 FU1-52 FU1-53	Protection of the motor from overheating without the use of external thermal relay. Refer to parameter descriptions for more detail.
Overload alarm and trip	FU1-54, FU1-55 FU1-56, FU1-57 FU1-58	Warning alarm outputs and displays the trip message when overcurrent above the threshold value keeps on.
Stall prevention	FU1-59, FU1-60	Set the output current level at which the output freq will be adjusted to prevent the motor from stoping due to over-current etc. it activates during accel/ constant speed/ decel to prevent the motor stall.

7) Starting / Accel/ Decel / Stopping pattern setting

Parameter Name	Code	Description
Accel/Decel pattern	FU1-05 FU1-06	5 types of Accel/ Decel pattern: 'Linear', 'S-curve', 'U-curve', 'Minimum', 'Optimum' settable according to application and load characteristic. If 'S-curve' is selected, the desired value of [FU2-17], [FU2-18] is settable.
Stopping method	FU1-07	3 types of stopping method 'Decel', 'DC-brake', 'Free-run' selectable. If 'DC-brake' is selected, the desired value of [FU1-8]~ [FU1-11] is settable.
Starting DC Injection Braking Voltage/ Time	FU1-12 FU1-13	The motor accelerates after the preset [FU1-12] for the preset [FU1-13] is applied. Starting DC injection braking is inactive when the value is set to 0 in control mode other than V/F and Slip compensation.
Frequency Limit selection	FU1-23 Fu1-24 FU1-25	Limits the active frequency. Inverter operates at the freq range between upper freq limit [FU1-25] and bottom freq limit [FU1-24] and higher/ lower freq value is entered, it is automatically replaced by limit value. Setting range: [FU1-20] Maximum freq to [FU1-21] Base freq.
Dynamic braking	FU2-75 FU2-76	Select the DB resistor mode when the regenerative load. Is connected. Refer to DBU manual for more details.

8) Operation-starting method

Parameter Name	Code	Description
Starting method	FU2-20 FU2-21 FU2-26 FU2-27	Motor starting method: [FU2-20] : Power-on run, [FU2-21] Restart after Fault Reset, [FU2-26] Number of Auto Restart Attempt [FU2-27] Delay Time Before Auto Restart See parameter description for more.
Speed Search Selection	FU2-22 FU2-23 FU2-24 FU2-25	Speed search function is available during Accel, trip, instant power failure, restart after fault reset and auto restart. See parameter description for more.

4.1.3 Advanced function 2 setting

1) PID operation

The inverter can be used to exercise process control, e.g. flow rate, air volume or pressure via PID feedback control.

Parameter Name	Code	Description
PID control setting	FU2-41~ FU2-60	Setting parameters for PID control

2) Jog and Multi-speed operation

Parameter Name	Code	Description
Multi function input terminal setting	I/O-12 ~14 EXT2 ~ 4	If I/O-12 ~14 are set to Speed-H, Speed-M, Speed-L, multi- speed operation up to speed 7 enable..
Filter time constant for input terminal	I/O-17	Effective for eliminating noise in the freq. setting circuit
Speed reference value	DRV-05 ~ 7 I/O-21 ~ I/O-24	Setting speed reference value for each step
Accel/Decel time setting for each step	I/O-25 ~ 38	Setting Accel/Decel time for each step
Jog freq.	I/O-20	Setting jog freq for jog operation

Speed-H	Speed-M	Speed-L	JOG	Speed Signal	Applied speed value
0	0	0	0	Speed 0	DRV-00
X	x	X	1	Jog freq.	I/O-20
0	0	1	0	Speed -1	DRV-05
0	1	0	0	Speed -2	DRV-06
0	1	1	0	Speed -3	DRV-07
1	0	0	0	Speed -4	I/O-21
1	0	1	0	Speed -5	I/O-22
1	1	0	0	Speed -6	I/O-23
1	1	1	0	Speed -7	I/O-24

3) Auto sequence operation

If I/O-50 [Auto (Sequence) Operation selection] is set to 1 {Auto-A} or 2 {Auto-B}, up to 5 sequences can be set with max of 8 steps (speed) in each sequence. Therefore, max 40 operating steps can be made. Two different types of auto sequence (A, B) operation are available.

Parameter Name	Code	Description
Auto operation setting	I/O-50 ~ 84	Set 8 steps and 5 sequences (Max)

-

4) 2nd motor operation

2nd function setting is required to run the two motors by one inverter by exchange. If the terminal defined for 2nd function signal input is turned ON, 2nd motor operation is valid.

Parameter Name	Code	Description
Multi-function input terminals setting	I/O-12 ~14 EXT2 ~ 4	2 nd motor operation is available with Multi-function input terminals P1 ~ P3 or P4 ~ 6 set to 7 {2 nd Func}.
Parameter setting for 2 nd motor operation	FU2-81 ~ FU2-90	Setting parameters necessary to operate 2 nd motor such as base freq., Accel/Decl time, Stall.

5) Energy-saving operation

FU1-39 [Energy Save Level] tunes the inverter output voltage to minimize the inverter output voltage during during constant speed operation. Appropriate for energy-saving applications such as fan, pump and HVAC.

4.2 Operation Example

Operation Example (1)		V/F Control + Analog Voltage Input (V1) + Operation via Terminal (FX/RX)	
<p>[Operation condition]</p> <ul style="list-style-type: none"> - Control mode : V/F control - Frequency command : 50[Hz] analog input via V1 terminal - Accel/Decel time : Accel – 15 [Sec], Decel – 25 [Sec] - Drive mode: Run/Stop via FX/RX terminal 			
<p>[Wiring]</p>			
Step	Parameter setting	Code	Description
1	Control Mode Selection	FU2-39	Set it to 0 {V/F}
2	Drive Mode	DRV-3	Set it to Fx/Rx-1.
3	Frequency Mode	DRV-4	set V1 Analog input value in frequency mode
4	50[Hz] freq command setting	DRV-0	set freq command 50[Hz] via V1(potentiometer)
5	Accel/Decel time	DRV-2 DRV-3	Set Accel time to 15 [Sec] in DRV-2 Set Decel time to 25 [Sec] in DRV-3
6	Terminal FX		Motor starts to rotate in Forward direction at 50Hz with Accel time 15 [sec] when FX terminal is turned ON. Motor decelerates to stop with Decel time 25[sec] when FX terminal is turned OFF.
7	Terminal RX		When RX terminal is turned ON motor starts to rotate in Reverse direction at 50[Hz] with Accel time 15 [Hz]. When it is OFF, motor decelerates to stop with Decel time 25 [Sec].

Operation example (2)		(V/F + PG) Control + operation (Run/Stop) via Keypad	
<p>[Operation condition]</p> <ul style="list-style-type: none"> - Control mode: V/F + PG control - Frequency command: 50[Hz] Digital input via Keypad - Accel time : 15[sec], Decel time : 25 [sec] - Drive mode : Run/Stop via Keypad - Wiring block diagram when an Open Collector- type encoder is used. 			
<p>[Wiring]</p>			
Step	Parameter setting	Code	Description
1	Control Mode Selection	FU2-39	Set it to 0 {V/F}.
2	Drive mode	DRV-3	Set it to 0 {KeyPad}.
3	Frequency Mode	DRV-4	Set it to 0 {KeyPad-1}.
4	Digital Command Frequency setting	DRV-0	Press PROG key on the keypad to set 50 Hz
5	Accel/Decel time setting	DRV-2 DRV-3	Accel time: set DRV-2 to 15[sec] Decel time: set DRV-3 to 25[sec]
6	Sub-B board setting	EXT-12 EXT-15 EXT-16	Set EXT-12 [Usage of Pulse Input Signal] to 1 {Feed-back} and set EXT-15 and EXT-16 after checking encoder rating on the nameplate.
7	FWD Operation		Motor runs at 50[Hz] in forward direction with Accel time 15[sec] by PG control when pressing FWD key on the keypad. Motor decelerates to stop with Decel time 25[sec] when pressing Stop key.
8	REV Operation		Motor runs at 50[Hz] in reverse direction with Accel time 15[sec] by PG control when pressing REV key on the keypad. Motor decelerates to stop with Decel time 25[sec] when pressing Stop key.

Operation Example (3) **2nd motor operation**

[Operation condition]

- Control mode: V/F control
- 1st motor + 2nd motor Operation by exchange using [2nd Func] (Values can be set differently)
- Frequency command : Using Multi-speed
 - 1st motor --- Apply 50[Hz] as main speed
 - 2nd motor --- Apply 20[Hz] with P1 terminal set as multi-speed operation
- Accel/Decel time : 1st motor --- Accel time: 15[Sec], Decel time: 25 [Sec]
 2nd motor --- Accel time: 30[Sec], Decel time: 40 [Sec]
- Drive mode : Run/Stop via FX/RX

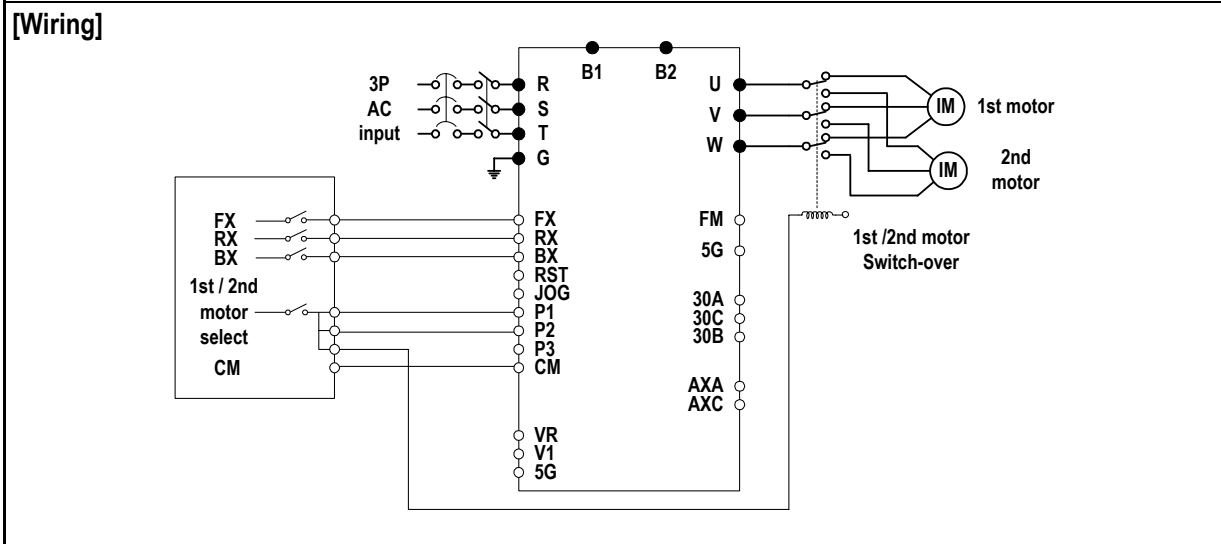

Step	Parameter setting	Code	Description
1	Control Mode Selection	FU2-39	Set it to 0 {V/F}.
2	Drive mode	DRV-3	Set it to Fx/Rx-1.
3	Frequency Mode setting	DRV-4	Set it to 0 {keypad-1}. (setting 1 st motor freq)
4	Multi-function input terminal P2	I/O-13	Set P2 to 2nd Func.
5	Multi-function input terminal P1	I/O-12	Set P1 to Speed-L. (setting 2 nd motor freq)
6	Freq setting for 1 st motor	DRV-0	Set it to 50[Hz].
7	Accel/Decel time setting for 1 st motor	DRV-1, DRV-2	Set Accel/Decel time to 15[sec]/25[sec].
8	Freq setting for 2 nd motor	DRV-5	Set it to 10[Hz].
9	Accel/Decel time setting for 2 nd motor	FU2-81/82	Set Accel/Decel time to 30[sec]/50[sec].
10	1 st motor operation		- Set it as main motor by turning P1, P2, output relay OFF. - Run the motor in FWD/REV direction using FX/RX terminal.
11	2 nd motor operation		- Set 2 nd motor parameters by turning terminal P2 ON. - Change the freq setting to 20[Hz] by turning terminal P1 ON. - Change 2 nd motor terminal by turning output relay ON. -Run the motor in FWD/REV direction by terminal FX/RX.

Operation Example (4)	Sensorless_S Control + Multi-speed operation + Analog output (FM)																				
[Operation condition]																					
<ul style="list-style-type: none"> - Control mode : Sensorless Speed control - Frequency command : Multi-function input from SUB-A and 8 step speed operation (Multi-speed 7 + jog freq 1) - Accel time : 5 [Sec], Decel time: 5 [Sec] - Drive mode : Run/Stop and speed output via terminal FX/RX 																					
[Wiring]																					
<table border="1" style="width: 100%; border-collapse: collapse; text-align: center;"> <thead> <tr> <th colspan="4">Multi-speed freq setting range</th> </tr> </thead> <tbody> <tr> <td>DRV-00</td> <td>Speed 0</td> <td>I/O-20</td> <td>Speed 4</td> </tr> <tr> <td>DRV-05</td> <td>Speed 1</td> <td>I/O-21</td> <td>Speed 5</td> </tr> <tr> <td>DRV-06</td> <td>Speed 2</td> <td>I/O-22</td> <td>Speed 6</td> </tr> <tr> <td>DRV-07</td> <td>Speed 3</td> <td>I/O-23</td> <td>Speed 7</td> </tr> </tbody> </table>		Multi-speed freq setting range				DRV-00	Speed 0	I/O-20	Speed 4	DRV-05	Speed 1	I/O-21	Speed 5	DRV-06	Speed 2	I/O-22	Speed 6	DRV-07	Speed 3	I/O-23	Speed 7
Multi-speed freq setting range																					
DRV-00	Speed 0	I/O-20	Speed 4																		
DRV-05	Speed 1	I/O-21	Speed 5																		
DRV-06	Speed 2	I/O-22	Speed 6																		
DRV-07	Speed 3	I/O-23	Speed 7																		
Step	Parameter setting	Code	Description																		
1	Control Mode Selection	FU2-39	Set it to Sensorless_S.																		
2	Drive mode	DRV-3	Set it to FX/RX-1.																		
3	Multi-function input	EXT-2 ~ 4	Set P3, P4, P5 to Speed-L, Speed-M, Speed-H.																		
4	FM (Frequency Meter) Output Selection	I/O-40	Set it to Frequency output																		
5	FM Output Adjustment	I/O-41	Output V = 10V x output freq x output gain (ex100%) / (Max freq x 100)																		
6	Terminal FX		Motor runs in forward direction at the set freq via P3, 4, 5 if Fx terminal is ON. Motor decelerates to stop with Decel time 5 [sec] if FX terminal is OFF.																		
7	Terminal RX		Motor runs in reverse direction at the set freq via P3, 4, 5 if RX terminal is ON. Motor decelerates to stop with Decel time 5 [sec] if RX terminal is OFF.																		

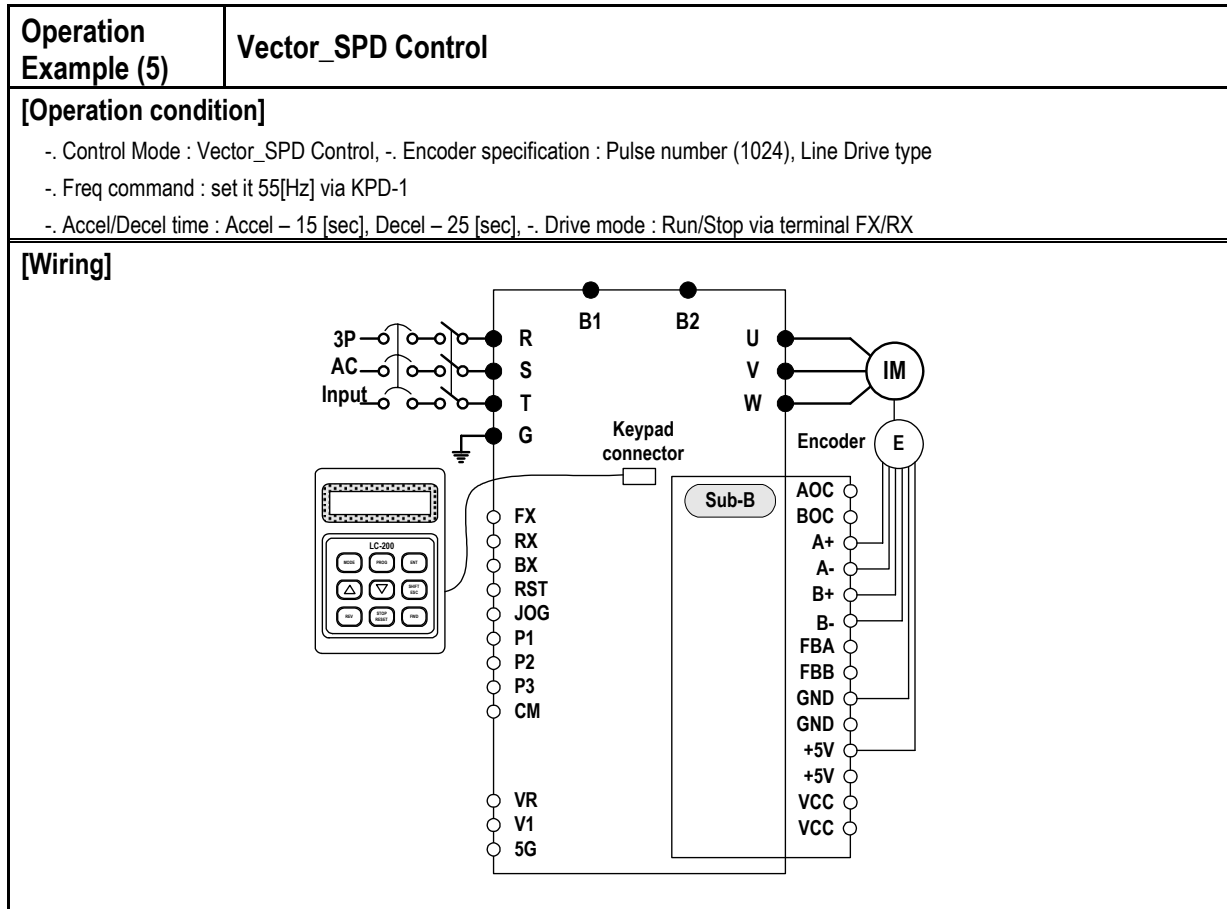

Step	Parameter setting	Code	Description
1	Motor related setting	FU2-30 ~ FU2-36	Set motor capacity, pole number, rated voltage/ current/slip and efficiency.
2	Encoder related setting	EXT-12 EXT-15 EXT-16	Set EXT-12 to Feed-back, EXT-1 to A+B Set EXT-16 to 1024
3	Control Mode Selection	Fu2-39	Encoder related setting should be done before setting control mode to Vector_SPD.
4	Auto-tuning	FU2-40	Auto-tuning starts when set to ALL. Read the encode rmanual carefully to clear the error if the messages " Enc Err", "Enc Rev" are displayed.
5	Keypad input setting	DRV-4 DRV-0	Set DRV-4 to KPD-1 and press the Prog key to set 55 [Hz] in Drv-0.
6	Accel/Decel time setting	DRV-1 DRV-2	Accel time: set 15[Sec] Decel time: set 25[Sec]
7	Drive mode	DRV-3	Set it to FX/RX-1.
8	FX/RX terminal		Motor runs with Accel time 15 [Sec] at 55 [Hz] if FX/RX terminal is turned ON. Motor decelerates to stop with Decel time 25 [Sec] if FX/RX terminal is turned OFF.

Notes:

CHAPTER 5 - PARAMETER LIST

5.1 Drive Group [DRV]

Code	Description	Keypad Display		Setting Range		Units	Factory Default	Adj. During Run	Page
		LCD	7-Segment	LCD	7-Segment				
DRV-00¹⁰	Command Frequency or Command Torque (Output Frequency/ Torque during motor run, Reference Frequency/ Torque during motor stop) Output Current (LCD)	Cmd. freq or Cmd. Trq	F or r (DRV-13)	0 to FU1-20 (Max. freq)		0.01	0.00 [Hz]	Yes	6-2
DRV-01	Acceleration Time	Acc. time	01	0 to 6000		0.1	10.0 [sec]	Yes	6-2
DRV-02	Deceleration Time	Dec. time	02	0 to 6000		0.1	20.0 [sec]	Yes	6-2
DRV-03	Drive Mode (Run/Stop Method)	Drive mode	03	Keypad	0	-	Fx/Rx-1	No	6-2
				Fx/Rx-1	1				
				Fx/Rx-2	2				
DRV-04	Frequency Mode or Torque Mode (Frequency/Torque setting Method)	Freq mode or Torque mode	04	Keypad-1	0	-	Keypad-1	No	6-2
				Keypad-2	1				
				V1	2				
				I	3				
				V1+I	4				
DRV-05	Step Frequency 1	Step freq-1	05	FU1-22 to FU1-20 (Starting freq to Max. freq)		0.01	10.00 [Hz]	Yes	6-2
DRV-06	Step Frequency 2	Step freq-2	06				20.00 [Hz]		
DRV-07	Step Frequency 3	Step freq-3	07				30.00 [Hz]		
DRV-08	Output Current	Current	08	The Load Current in RMS		-	[A]	-	6-2
DRV-09	Motor Speed	Speed	09	The Motor Speed in rpm		-	[rpm]	-	6-2
DRV-10	DC link Voltage	DC link Vtg	10	The DC Link Voltage inside inverter		-	[V]	-	6-2
DRV-11	User Display Selection	User disp	11	Selected in FU2-73 (User Disp)		-	-	-	6-2
DRV-12	Fault Display	Fault	12	-	-	-	None nOn	-	6-2
DRV-13	Motor Direction Set	Not displayed in LCD keypad	13	Not available	0 [Forward]	-	0	Yes	6-2
					1 [reverse]				
DRV-14	Target/Output Frequency Display	TAR OUT	14	-	-	-	0.00 [Hz]	Yes	6-2
DRV-15¹¹	Reference/Feedback Frequency Display	REF FBK	15	-	-	-	0.00 [Hz]	Yes	6-2
DRV-16	Speed Unit Selection	Hz/Rpm Disp	16	Hz disp	0	-	-	Yes	6-2

¹⁰ The speed unit is changed to [%] when FU2-39 is set to 'Sensorless_T' or 'Vector_TRQ'.

¹¹ Code DRV-15 appears only when FU2-47 is set to 'Yes'.

Chapter 5 - Parameter List

Code	Description	Keypad Display		Setting Range		Units	Factory Default	Adj. During Run	Page
		LCD	7-Segment	LCD	7-Segment				
				Rpm disp	1				
DRV-20	FU1 Group Selection	Not displayed in LCD keypad	20	Not available	Press [PROG/ENT] key	-	1	Yes	6-2
DRV-21	FU2 Group Selection		21						6-2
DRV-22	I/O Group Selection		22						6-2
DRV-23 ¹²	EXT Group Selection		23						6-2
DRV-24	COM Group Selection		24						6-2
DRV-25	APP Group Selection		25						6-2

¹² Code DRV-23 through DRV-24 appears only when a Sub-Board or an Option Board is installed.

5.2 Function 1 Group [FU1]

Code	Description	Keypad Display		Setting Range		Units	Factory Default	Adj. During Run	Page
		LCD	7-Segment	LCD	7-Segment				
FU1-00	Jump to Desired Code #	Jump code	Not displayed	1 to 60	Not available	1	1	Yes	6-2
FU1-03	Run Prevention	Run Prev.	03	None Forward Prev Reverse Prev	0 1 2	-	None	No	6-2
FU1-05	Acceleration Pattern	Acc. pattern	05	Linear S-curve U-curve Minimum Optimum	0 1 2 3 4	-	Linear	No	6-2
FU1-06	Deceleration Pattern	Dec. pattern	06	Linear S-curve U-curve Minimum Optimum	0 1 2 3 4	-	Linear	No	6-2
FU1-07	Stop Mode	Stop mode	07	Decel DC-brake Free-run	0 1 2	-	Decel	No	6-2
FU1-08 ¹³	DC Injection Braking Frequency	DcBr freq	08	FU1-22 to 60 [Hz]		0.01	5.00 [Hz]	No	6-2
FU1-09	DC Injection Braking On-delay Time	DcBlk time	09	0 to 60 [sec]		0.01	0.1 [sec]	No	
FU1-10	DC Injection Braking Voltage	DcBr value	10	0 to 200 [%]		1	50 [%]	No	
FU1-11	DC Injection Braking Time	DcBr time	11	0 to 60 [sec]		0.1	1.0 [sec]	No	
FU1-12	Starting DC Injection Braking Voltage	DcSt value	12	0 to 200 [%]		1	50 [%]	No	6-2
FU1-13	Starting DC Injection Braking Time	DcSt time	13	0 to 60 [sec]		0.1	0.0 [sec]	No	
FU1-14	Pre-excitation Time	PreExTime	14	0 to 60 [sec]		0.1	1.0 [sec]	No	6-2
FU1-15	Hold Time	Hold Time	15	0 to 1000 [ms]		1	1000 [ms]	No	6-2
FU1-16	Pre-excitation Current	Flux Force	16	100 to 500 [%]		0.1	100.0 [%]	No	6-2
FU1-20	Maximum Frequency	Max freq	20	40 to 400 [Hz]		0.01	60.00 [Hz]	No	6-2
FU1-21	Base Frequency	Base freq	21	30 to FU1-20		0.01	60.00 [Hz]	No	
FU1-22	Starting Frequency	Start freq	22	0.01 to 60 [Hz]		0.01	0.50 [Hz]	No	
FU1-23	Frequency Limit selection	Freq limit	23	No Yes	0 1	-	No	No	6-2
FU1-24 ¹⁴	Low Limit Frequency	F-limit Lo	24	FU1-22 to FU1-25		0.01	0.50 [Hz]	No	

¹³ Code FU1-08 through FU1-11 appears only when FU1-07 is set to 'DC-Brake'.¹⁴ Code FU1-24 through FU1-25 appears only when FU1-23 is set to 'Yes'.

Chapter 5 - Parameter List

Code	Description	Keypad Display		Setting Range		Units	Factory Default	Adj. During Run	Page
		LCD	7-Segment	LCD	7-Segment				
FU1-25	High Limit Frequency	F-limit Hi	25	FU1-24 to FU1-20		0.01	60.00 [Hz]	No	
FU1-26	Manual/Auto Torque Boost Selection	Torque boost	26	Manual Auto	0 1	-	Manual	No	6-2
FU1-27	Torque Boost in Forward Direction	Fwd boost	27	0 to 15 [%]		0.1	2.0 [%]	No	6-2
FU1-28	Torque Boost in Reverse Direction	Rev boost	28	0 to 15 [%]		0.1	2.0 [%]	No	
FU1-29	Volts/Hz Pattern	V/F pattern	29	Linear Square User V/F	0 1 2	-	Linear	No	6-2
FU1-30 ¹⁵	User V/F – Frequency 1	User freq 1	30	0 to FU1-20		0.01	15.00 [Hz]	No	6-2
FU1-31	User V/F – Voltage 1	User volt 1	31	0 to 100 [%]		1	25 [%]	No	
FU1-32	User V/F – Frequency 2	User freq 2	32	0 to FU1-20		0.01	30.00 [Hz]	No	
FU1-33	User V/F – Voltage 2	User volt 2	33	0 to 100 [%]		1	50 [%]	No	
FU1-34	User V/F – Frequency 3	User freq 3	34	0 to FU1-20		0.01	45.00 [Hz]	No	
FU1-35	User V/F – Voltage 3	User volt 3	35	0 to 100 [%]		1	75 [%]	No	
FU1-36	User V/F – Frequency 4	User freq 4	36	0 to FU1-20		0.01	60.00 [Hz]	No	
FU1-37	User V/F – Voltage 4	User volt 4	37	0 to 100 [%]		1	100 [%]	No	
FU1-38	Output Voltage Adjustment	Volt control	38	40 to 110 [%]		0.1	100.0 [%]	No	6-2
FU1-39	Energy Save Level	Energy save	39	0 to 30 [%]		1	0 [%]	Yes	6-2
FU1-50	Electronic Thermal Selection	ETH select	50	No Yes	0 1	-	No	Yes	6-2
FU1-51 ¹⁶	Electronic Thermal Level for 1 Minute	ETH 1 min	51	FU1-52 to 200 [%]		1	150 [%]	Yes	
FU1-52	Electronic Thermal Level for Continuous	ETH cont	52	50 to FU1-51		1	100 [%]	Yes	
FU1-53	Electronic Thermal Characteristic Selection (Motor Type)	Motor type	53	Self-cool Forced-cool	0 1	-	Self-cool	Yes	6-2
FU1-54	Overload Warning Level	OL level	54	30 to 150 [%]		1	150 [%]	Yes	
FU1-55	Overload Warning Hold Time	OL time	55	0 to 30 [sec]		0.1	10.0 [sec]	Yes	6-2
FU1-56	Overload Trip Selection	OLT select	56	No Yes	0 1	-	Yes	Yes	6-2
FU1-57	Overload Trip Level	OLT level	57	30 to 150 [%]		1	180 [%]	Yes	
FU1-58	Overload Trip Delay Time	OLT time	58	0 to 60 [sec]		1	60.0 [sec]	Yes	
FU1-59	Stall Prevention Mode Selection	Stall prev.	59	000 to 111 (Bit Set)		bit	000	No	6-2
FU1-60	Stall Prevention Level	Stall level	60	30 to 250 [%]		1	180 [%]	No	

¹⁵ Code FU1-30 through FU1-37 appears only when FU1-29 is set to 'User V/F'.

¹⁶ Code FU1-51 through FU1-53 appears only when FU1-50 is set to 'Yes'.

Code	Description	Keypad Display		Setting Range		Units	Factory Default	Adj. During Run	Page
		LCD	7-Segment	LCD	7-Segment				
FU1-99	Return Code	Not displayed	99	Not available	[PROG/ENT] or [SHIFT/ESC]	-	-	-	6-2

5.3 Function 2 Group [FU2]

Code	Description	Keypad Display		Setting Range		Units	Factory Default	Adj. During Run	Page
		LCD	7-Segment	LCD	7-Segment				
FU2-00	Jump to desired code #	Jump code	Not displayed	1 to 94	Not available	1	1	Yes	6-2
FU2-01	Previous Fault History 1	Last trip-1	01	By pressing [PROG] and [▲] key, the frequency, current, and operational status at the time of fault can be seen.		-	None	-	6-2
FU2-02	Previous Fault History 2	Last trip-2	02						
FU2-03	Previous Fault History 3	Last trip-3	03						
FU2-04	Previous Fault History 4	Last trip-4	04						
FU2-05	Previous Fault History 5	Last trip-5	05						
FU2-06	Erase Fault History	Erase trips	06	No Yes	0 1	-	No	Yes	
FU2-07	Dwell Frequency	Dwell freq	07	FU1-22 to FU1-20		0.01	5.00 [Hz]	No	6-2
FU2-08	Dwell Time	Dwell time	08	0 to 10 [sec]		0.1	0.0 [sec]	No	
FU2-10	Frequency Jump Selection	Jump freq	10	No Yes	0 1	-	No	No	6-2
FU2-11 ¹⁷	Jump Frequency 1 Low	Jump lo 1	11	FU1-22 to FU2-12		0.01	10.00 [Hz]	No	
FU2-12	Jump Frequency 1 High	Jump Hi 1	12	FU2-11 to FU1-20		0.01	15.00 [Hz]	No	
FU2-13	Jump Frequency 2 Low	Jump lo 2	13	FU1-22 to FU2-14		0.01	20.00 [Hz]	No	
FU2-14	Jump Frequency 2 High	Jump Hi 2	14	FU2-13 to FU1-20		0.01	25.00 [Hz]	No	
FU2-15	Jump Frequency 3 Low	Jump lo 3	15	FU1-22 to FU2-16		0.01	30.00 [Hz]	No	
FU2-16	Jump Frequency 3 High	Jump Hi 3	16	FU2-15 to FU1-20		0.01	35.00 [Hz]	No	
FU2-17	Start Curve for S-Curve Accel/Dedel Pattern	Start Curve	17	1 to 100 [%]		1	40%	No	6-2
FU2-18	End Curve for S-Curve Accel/Dedel Pattern	End Curve	18	1 to 100 [%]		1	40%	No	
FU2-19	Input/Output Phase Loss Protection	Trip select	19	00 to 11 (Bit Set)		-	00	Yes	6-2
FU2-20	Power ON Start Selection	Power-on run	20	No Yes	0 1	-	No	Yes	6-2
FU2-21	Restart after Fault Reset	RST restart	21	No Yes	0 1	-	No	Yes	6-2
FU2-22	Speed Search Selection	Speed Search	22	0000 to 1111 (Bit Set)		-	0000	No	6-2
FU2-23	Current Limit Level During Speed Search	SS Sup-Curr	23	80 to 200 [%]		1	100 [%]	Yes	
FU2-24	P Gain During Speed Search	SS P-gain	24	0 to 30000		1	100	Yes	
FU2-25	I Gain During speed search	SS I-gain	25	0 to 30000		1	1000	Yes	
FU2-26	Number of Auto Restart Attempt	Retry number	26	0 to 10		1	0	Yes	6-2

¹⁷ Code FU2-11 through FU2-16 appears only when FU2-10 is set to 'Yes'.

Code	Description	Keypad Display		Setting Range		Units	Factory Default	Adj. During Run	Page
		LCD	7-Segment	LCD	7-Segment				
FU2-27	Delay Time Before Auto Restart	Retry Delay	27	0 to 60 [sec]		0.1	1.0 [sec]	Yes	6-2
FU2-28	Speed Search Hold Time	SS blk time	28	0 to 60 [sec]		0.1	1.0 [sec]	No	6-2
FU2-30	Rated Motor Selection	Motor select	30	0.75kW	0	-	18	No	6-2
				1.5kW	1				
				2.2kW	2				
				3.7kW	3				
				5.5kW	4				
				7.5kW	5				
				11.0kW	6				
				15.0kW	7				
				18.5kW	8				
				22.0kW	9				
FU2-31	Number of Motor Poles	Pole number	31	2 to 12		1	4	No	
FU2-32	Rated Motor Slip	Rated-Slip	32	0 to 10 [Hz]		0.01	19	No	
FU2-33	Rated Motor Current (RMS)	Rated-Curr	33	1 to 200 [A]		1		No	
FU2-34	No Load Motor Current (RMS)	NoLoad-Curr	34	0.5 to 200 [A]		1		No	
FU2-36	Motor Efficiency	Efficiency	36	70 to 100 [%]		1		No	
FU2-37	Load Inertia	Inertia rate	37	0 to 1		1	0	No	
FU2-38	Carrier Frequency	Carrier freq	38	1 to 15 [kHz]		1	5 [kHz]	Yes	6-2
FU2-39	Control Mode Selection	Control mode	40	V/F	0	-	V/F	No	6-2
				Slip comp	1				
				Sensorless_S	2				
				Sensorless_T	3				
				Vector_SPD	4				
				Vector_TRQ	5				
FU2-40	Auto Tuning	Auto tuning	41	No	0	-	No	No	6-2
				All	1				
				Rs + Lsigma					
				Enc Test					
				Tr					
FU2-41 ²⁰	Stator Resistance of Motor	Rs	42	0 to (depending on FU2-30) [ohm]		0.001	21	No	
FU2-42	Leakage Inductance of Motor	Lsigma	44	0 to (depending on FU2-30) [mH]		0.001		No	

¹⁸ The rated motor is automatically set according to the inverter model name. If different, set the motor capacity connected.

¹⁹ This value is automatically entered according to the rated motor set in FU2-30. If different, set the correct value of the motor.

²⁰ Code FU2-41 through FU2-46 appears only when FU2-39 is set to 'Sensorless_X' or 'Vector_XXX'.

²¹ This value is automatically entered according to the rated motor set in FU2-30. If different, set the correct value of the motor.

Chapter 5 - Parameter List

Code	Description	Keypad Display		Setting Range		Units	Factory Default	Adj. During Run	Page
		LCD	7-Segment	LCD	7-Segment				
FU2-43	Stator Inductance of Motor	Ls	43	0 to (depending on FU2-30) [mH]				No	
FU2-44	Rotor Time Constant	Tr	44	0 to (depending on FU2-30) [mH]				No	
FU2-45	P Gain for Sensorless Control	SL P-gain	45	0 to 32767		1	1000	Yes	6-2
FU2-46	I Gain for Sensorless Control	SL I-gain	46	0 to 32767		1	100	Yes	
FU2-47	PID Operation Selection	proc PI mode	47	No Yes	0 1	-	No	No	6-2
FU2-48 ²²	PID Reference Frequency Selection	PID Ref	48	Ramp freq. Target freq.	0 1	-	Ramp freq.	No	6-2
FU2-49	PID Reference Mode Selection	PID Ref Mode	49	Freq mode Keypad-1 Keypad-2 V1 I V2	0 1 2 3 4 5	-	Freq mode	No	6-2
FU2-50	PID Output Direction Selection	PID Out Dir	50	Ramp freq. Target freq.	0 1	-	Ramp freq.	No	6-2
FU2-51	PID Feedback Signal Selection	PID F/B	51	I V1 V2	0 1 2	-	I	No	
FU2-52	P Gain for PID Control	PID P-gain	52	0 to 999.9 [%]		0.1	100.0 [%]	Yes	6-2
FU2-53	I Gain for PID Control	PID I-time	53	0 to 32.0 [sec]		0.1	30.0 [sec]	Yes	
FU2-54	D Gain for PID Control	PID D-time	54	0 to 999.9 [msec]		0.1	0.0 [msec]	Yes	
FU2-55	High Limit Frequency for PID Control	PID +limit	55	0 to 99.99 [Hz]		0.01	60.00 [Hz]	Yes	
FU2-56	Low Limit Frequency for PID Control	PID -limit	56	0 to 99.99 [Hz]		0.01	60.00 [Hz]	Yes	
FU2-57	PID Output Inversion	PID Out Inv.	57	No Yes	0 1	-	No	No	
FU2-58	PID Output Scale	PID OutScale	58	0 to 999.9 [%]		0.1	100 [%]	No	6-2
FU2-59	PID P2 Gain	PID P2-gain	59	0 to 100 [%]		0.1	100 [%]	No	
FU2-60	P Gain Scale	P-gain Scale	60	0 to 100 [%]		0.1	100 [%]	No	
FU2-69	Accel/Decel Change Frequency	Acc/Dec ch F	69	0 to FU1-20				No	6-2
FU2-70	Reference Frequency for Accel and Decel	Acc/Dec freq	70	Max freq Delta freq	0 1	-	Max freq	No	6-2
FU2-71	Accel/Decel Time Scale	Time scale	71	0.01 [sec] 0.1 [sec] 1 [sec]	0 1 2	0.01	0.1 [sec]	Yes	6-2

²² Code FU2-48 through FU2-60 appears only when FU2-47 is set to 'Yes'.

Code	Description	Keypad Display		Setting Range		Units	Factory Default	Adj. During Run	Page
		LCD	7-Segment	LCD	7-Segment				
FU2-72	Power On Display	PowerOn disp	72	0 to 12		1	0	Yes	6-2
FU2-73	User Display Selection	User disp	73	Voltage Watt	0 1	-	Voltage	Yes	6-2
FU2-74	Gain for Motor Speed Display	RPM factor	74	1 to 1000 [%]		1	100 [%]	Yes	6-2
FU2-75	DB (Dynamic Braking) Resistor Mode Selection	DB mode	75	None Int. DB-R Ext. DB-R	0 1 2	-	Int. DB-R	Yes	6-2
FU2-76 ²³	Duty of Dynamic Braking Resistor	DB %ED	76	0 to 30 [%]		1	10 [%]	Yes	6-2
FU2-79	Software Version	S/W version	79	Ver 2.0		-	-	-	6-2
FU2-81 ²⁴	2 nd Acceleration Time	2nd Acc time	81	0 to 6000 [sec]		0.1	5.0 [sec]	Yes	6-2
FU2-82	2 nd Deceleration Time	2nd Dec time	82	0 to 6000 [sec]		0.1	10.0 [sec]	Yes	
FU2-83	2 nd Base Frequency	2nd BaseFreq	83	30 to FU1-20		0.01	60.00 [Hz]	No	
FU2-84	2 nd V/F Pattern	2nd V/F	84	Linear Square User V/F	0 1 2	-	Linear	No	
FU2-85	2 nd Forward Torque Boost	2nd F-boost	85	0 to 15 [%]		0.1	2.0 [%]	No	
FU2-86	2 nd Reverse Torque Boost	2nd R-boost	86	0 to 15 [%]		0.1	2.0 [%]	No	
FU2-87	2 nd Stall Prevention Level	2nd Stall	87	30 to 150 [%]		1	150 [%]	No	
FU2-88	2 nd Electronic Thermal Level for 1 minute	2nd ETH 1min	88	FU2-89 to 200 [%]		1	150 [%]	Yes	
FU2-89	2 nd Electronic Thermal Level for continuous	2nd ETH cont	89	50 to FU2-88 (Maximum 150%)		1	100 [%]	Yes	
FU2-90	2 nd Rated Motor Current	2nd R-Curr	90	1 to 200 [A]		0.1	3.6 [A]	No	
FU2-91	Read Parameters into Keypad from Inverter	Para. Read	91	No Yes	0 1	-	No	No	6-2
FU2-92	Write Parameters to Inverter from Keypad	Para. Write	92	No Yes	0 1	-	No	No	
FU2-93	Initialize Parameters	Para. Init	93	No All Groups DRV FU1 FU2 I/O EXT COM APP	0 1 2 3 4 5 6 7 8	-	No	No	6-2

²³ Code FU2-76 appears only when FU2-75 is set to 'Ext. DB-R'.

²⁴ Code FU2-81 through FU2-90 appear only when one of I/O-12 ~ I/O-14 is set to '2nd function'.

Chapter 5 - Parameter List

Code	Description	Keypad Display		Setting Range		Units	Factory Default	Adj. During Run	Page
		LCD	7-Segment	LCD	7-Segment				
FU2-94	Parameter Write Protection	Para. Lock	94	0 to 255		1	0	Yes	6-2
FU2-99	Return Code	Not displayed	99	Not available	[PROG/ENT] or [SHIFT/ESC]	-	1	Yes	6-2

5.4 Input/Output Group [I/O]

Code	Description	Keypad Display		Setting Range		Units	Factory Default	Adj. During Run	Page
		LCD	7-Segment	LCD	7-Segment				
I/O-00	Jump to Desired Code #	Jump code	Not displayed	1 to 84	Not available	1	1	Yes	6-2
I/O-01	Filtering Time Constant for V1 Signal Input	V1 filter	01	0 to 10000 [ms]		1	10 [ms]	Yes	6-2
I/O-02	V1 Input Minimum Voltage	V1 volt x1	02	0 to 10 [V]		0.01	0.00 [V]	Yes	
I/O-03	Frequency Corresponding to V1 Input Minimum Voltage	V1 freq y1	03	0 to FU1-20		0.01	0.00 [Hz]	Yes	
I/O-04	V1 Input Maximum Voltage	V1 volt x2	04	0 to 10 [V]		0.01	10.00 [V]	Yes	
I/O-05	Frequency Corresponding to V1 Input Maximum Voltage	V1 freq y2	05	0 to FU1-20		0.01	60.00 [Hz]	Yes	
I/O-06	Filtering Time Constant for I Signal Input	I filter	06	0 to 10000 [ms]		1	10 [ms]	Yes	6-2
I/O-07	I Input Minimum Current	I curr x1	07	0 to 20 [mA]		0.01	4.00 [mA]	Yes	
I/O-08	Frequency Corresponding to I Input Minimum Current	I freq y1	08	0 to FU1-20		0.01	0.00 [Hz]	Yes	
I/O-09	I Input Maximum Current	I curr x2	09	0 to 20 [mA]		0.01	20.00 [mA]	Yes	6-2
I/O-10	Frequency Corresponding to I Input Maximum Current	I freq y2	10	0 to FU1-20		0.01	60.00 [Hz]	Yes	
I/O-11	Criteria for Analog Input Signal Loss	Wire broken	11	None half x1 below x1	0 1 2	-	None	Yes	6-2
I/O-12	Multi-Function Input Terminal 'P1' Define	P1 define	12	Speed-L Speed-M Speed-H XCEL-L XCEL-M XCEL-H Dc-brake 2nd Func Exchange - Reserved -	0 1 2 3 4 5 6 7 8 9	-	Speed-L	Yes	6-2

Code	Description	Keypad Display		Setting Range		Units	Factory Default	Adj. During Run	Page
		LCD	7-Segment	LCD	7-Segment				
				Up	10				
				Down	11				
				3-Wire	12				
				Ext Trip-A	13				
				Ext Trip-B	14				
				iTerm Clear	15				
				Open-loop	16				
				Main-drive	17				
				Analog hold	18				
				XCEL stop	19				
				P Gain2	20				
				SEQ-L	21				
				SEQ-M	22				
				SEQ-H	23				
				Manual	24				
				Go step	25				
				Hold step	26				
				Trv Off.Lo	27				
				Trv Off.Hi	28				
				Interlock1	29				
				Interlock2	30				
				Interlock3	31				
				Interlock4	32				
				Pre excite	33				
				Spd/Trq	34				
				ASR P/PI	35				
I/O-13	Multi-function Input Terminal 'P2' Define	P2 define	13	Same as Above		-	Speed-M	Yes	6-2
I/O-14	Multi-function Input Terminal 'P3' Define	P3 define	14			-	Speed-H	Yes	
I/O-15	Terminal Input Status	In status	15	00000000 to 11111111		-	-	-	6-2
I/O-16	Terminal Output Status	Out status	16	0000 to 1111		-	-	-	
I/O-17	Filtering Time Constant for Multi-Function Input Terminals	Ti Filt Num	17	2 to 50		1	2	Yes	6-2
I/O-20	Jog Frequency Setting	Jog freq	20	FU1-22 to FU1-20		0.01	10.00 [Hz]	Yes	6-2
I/O-21	Step Frequency 4	Step freq-4	21				40.00 [Hz]	Yes	
I/O-22	Step Frequency 5	Step freq-5	22				50.00 [Hz]	Yes	
I/O-23	Step Frequency 6	Step freq-6	23				40.00 [Hz]	Yes	
I/O-24	Step Frequency 7	Step freq-7	24				30.00 [Hz]	Yes	
I/O-25	Acceleration Time 1 for Step Frequency	Acc time-1	25	0 to 6000 [sec]		0.1	20.0 [sec]	Yes	6-2

Chapter 5 - Parameter List

Code	Description	Keypad Display		Setting Range		Units	Factory Default	Adj. During Run	Page
		LCD	7-Segment	LCD	7-Segment				
I/O-26	Deceleration Time 1 for Step Frequency	Dec time-1	26	0 to 6000 [sec]		0.1	20.0 [sec]	Yes	
I/O-27	Acceleration Time 2	Acc time-2	27	0 to 6000 [sec]		0.1	30.0 [sec]	Yes	
I/O-28	Deceleration Time 2	Dec time-2	28	0 to 6000 [sec]		0.1	30.0 [sec]	Yes	
I/O-29	Acceleration Time 3	Acc time-3	29	0 to 6000 [sec]		0.1	40.0 [sec]	Yes	
I/O-30	Deceleration Time 3	Dec time-3	30	0 to 6000 [sec]		0.1	40.0 [sec]	Yes	
I/O-31	Acceleration Time 4	Acc time-4	31	0 to 6000 [sec]		0.1	50.0 [sec]	Yes	
I/O-32	Deceleration Time 4	Dec time-4	32	0 to 6000 [sec]		0.1	50.0 [sec]	Yes	
I/O-33	Acceleration Time 5	Acc time-5	33	0 to 6000 [sec]		0.1	40.0 [sec]	Yes	
I/O-34	Deceleration Time 5	Dec time-5	34	0 to 6000 [sec]		0.1	40.0 [sec]	Yes	
I/O-35	Acceleration Time 6	Acc time-6	35	0 to 6000 [sec]		0.1	30.0 [sec]	Yes	
I/O-36	Deceleration Time 6	Dec time-6	36	0 to 6000 [sec]		0.1	30.0 [sec]	Yes	
I/O-37	Acceleration Time 7	Acc time-7	37	0 to 6000 [sec]		0.1	20.0 [sec]	Yes	
I/O-38	Deceleration Time 7	Dec time-7	38	0 to 6000 [sec]		0.1	20.0 [sec]	Yes	
I/O-40	FM (Frequency Meter) Output Selection	FM mode	40	Frequency	0	-	Frequency	Yes	6-2
				Current	1				
				Voltage	2				
				DC link Vtg	3				
				Torque	4				
I/O-41	FM Output Adjustment	FM adjust	41	10 to 200 [%]		1	100 [%]	Yes	
I/O-42	Frequency Detection Level	FDT freq	42	0 to FU1-20		0.01	30.00 [Hz]	Yes	
I/O-43	Frequency Detection Bandwidth	FDT band	43	0 to FU1-20		0.01	10.00 [Hz]	Yes	6-2
I/O-44	Multi-Function Auxiliary Contact Output Define (AXA, AXC)	Aux mode	44	FDT-1	0	-	Run	Yes	6-2
				FDT-2	1				
				FDT-3	2				
				FDT-4	3				
				FDT-5	4				
				OL	5				
				IOL	6				
				Stall	7				
				OV	8				
				LV	9				
				OH	10				
				Lost Command	11				
				Run	12				
				Stop	13				
				Steady	14				
				INV line	15				
				COMM line	16				
				Ssearch	17				
				Step pulse	18				

Code	Description	Keypad Display		Setting Range		Units	Factory Default	Adj. During Run	Page
		LCD	7-Segment	LCD	7-Segment				
				Seq pulse	19				
				Ready	20				
				Trv. ACC	21				
				Trv. DEC	22				
				MMC	23				
				Zspd Dect	24				
				Torq Dect	25				
I/O-45	Fault Output Relay Setting (30A, 30B, 30C)	Relay mode	45	000 to 111 (Bit Set)		-	010	Yes	6-2
I/O-46 ²⁵	Inverter Number	Inv No.	46	1 to 31		1	1	Yes	6-2
I/O-47	Baud Rate	Baud rate	47	1200 bps 2400 bps 4800 bps 9600 bps 19200 bps	0 1 2 3 4	-	9600 bps	Yes	6-2
I/O-48	Operating selection at Loss of Freq. Reference	Lost command	48	None FreeRun Stop	0 1 2	-	None	Yes	6-2
I/O-49	Waiting Time after Loss of Freq. Reference	Time out	49	0.1 to 120 [sec]		0.1	1.0 [sec]	Yes	
I/O-50	Auto (Sequence) Operation selection	Auto mode	50	None Auto-A Auto-B	0 1 2	-	None	No	
I/O-51	Sequence Number Selection	Seq select	51	1 to 5		1	1	Yes	6-2
I/O-52	The Number of Steps of Sequence Number #	Step number	52	1 to 8		1	2	Yes	
I/O-53 ²⁶	1 st Step Frequency of Sequence 1	Seq1 / 1F	53	0.01 to FU1-20		0.01	11.00 [Hz]	Yes	
I/O-54	Transient Time to 1 st Step of Sequence 1	Seq1 / 1T	54	0.1 to 6000 [sec]		0.1	1.1 [sec]	Yes	
I/O-55	Steady Speed Time at 1 st Step of Sequence 1	Seq1 / 1S	55	0.1 to 6000 [sec]		0.1	1.1 [sec]	Yes	6-2
I/O-56	Motor Direction of 1 st Step of Sequence 1	Seq1 / 1D	56	Reverse Forward	0 1	-	Forward	Yes	
I/O-57	1 st Step Frequency of Sequence 2	Seq1 / 2F	57	0.01 to FU1-20		0.01	21.00 [Hz]	Yes	

²⁵ Code I/O-46 through I/O-49 are used in Option Board like RS485, Device, Net and F-net etc.

²⁶ The 'seq#' of code I/O-53 through I/O-60 varies according to the sequence number selected in I/O-51.

The parameter code may be extended to I/O-84 depending the number of steps set in I/O-52 because the steps can be set up to 8.

Chapter 5 - Parameter List

Code	Description	Keypad Display		Setting Range		Units	Factory Default	Adj. During Run	Page
		LCD	7-Segment	LCD	7-Segment				
I/O-58	Transient Time to 1 st Step of Sequence 2	Seq1 / 2T	58	0.1 to 6000 [sec]		0.1	1.1 [sec]	Yes	6-2
I/O-59	Steady Speed Time at 1 st Step of Sequence 2	Seq1 / 2S	59	0.1 to 6000 [sec]		0.1	1.1 [sec]	Yes	
I/O-60	Motor Direction of 1 st Step of Sequence 2	Seq1 / 2D	60	Reverse Forward	0 1	-	Forward	Yes	
I/O-99	Return Code	Not displayed	99	Not available	[PROG/ENT] or [SHIFT/ESC]	-	1	Yes	

5.5 External Group [EXT]

EXT group appears only when the corresponding Sub-Board is installed.

Code	Description	Keypad Display		Setting Range		Units	Factory Default	Adj. During Run	Page
		LCD	7-Segment	LCD	7-Segment				
EXT-00	Jump to Desired Code #	Jump code	Not displayed	0 to 99	Not available	1	1	Yes	6-2
EXT-01	Sub Board Type Display	Sub B/D	01	None SUB-A SUB-B SUB-C SUB-D SUB-E SUB-F SUB-G SUB-H	0 1 2 3 4 5 6 7 8	-	None	Automatically set	6-2
EXT-02	Multi-Function Input Terminal 'P4' Define	P4 define	02	Speed-L Speed-M Speed-H XCEL-L XCEL-M XCEL-H Dc-brake 2nd Func Exchange - Reserved - Up Down 3-Wire Ext Trip-A Ext Trip-B iTerm Clear Open-loop	0 1 2 3 4 5 6 7 8 9 10 11 12 13 14 15 16	-	XCEL-L	Yes	6-2

Code	Description	Keypad Display		Setting Range		Units	Factory Default	Adj. During Run	Page
		LCD	7-Segment	LCD	7-Segment				
				Main-drive	17				
				Analog hold	18				
				XCEL stop	19				
				P Gain2	20				
				SEQ-L	21				
				SEQ-M	22				
				SEQ-H	23				
				Manual	24				
				Go step	25				
				Hold step	26				
				Trv Off.Lo	27				
				Trv Off.Hi	28				
				Interlock1	29				
				Interlock2	30				
				Interlock3	31				
				Interlock4	32				
				Pre excite	33				
				Spd/Trq	34				
				ASR P/PI	35				
EXT-03	Multi-Function Input Terminal 'P5' Define	P5 define	03	Same as Above		-	XCEL-M	Yes	6-2
EXT-04	Multi-Function Input Terminal 'P6' Define	P6 define	04			-	XCEL-H	Yes	
EXT-05	V2 Mode Selection	V2 mode	05	None	0	-	None	No	6-2
				Override	1				
				Reference	2				
EXT-06	Filtering Time Constant for V2 Input Signal	V2 filter	06	0 to 10000 [ms]		1	10 [ms]	Yes	6-2
EXT-07	V2 Input Minimum Voltage	V2 volt x1	07	0 to 10 [V]		0.01	0.00 [V]	Yes	
EXT-08	Frequency Corresponding to V2 Input Minimum Voltage	V2 freq y1	08	0 to FU1-20		0.01	0.00 [Hz]	Yes	
EXT-09	V2 Input Maximum Voltage	V2 volt x2	09	0 to 10 [V]		0.01	10.00 [V]	Yes	
EXT-10	Frequency Corresponding to V2 Input Maximum Voltage	V2 freq y2	10	0 to FU1-20		0.01	60.00 [Hz]	Yes	
EXT-12	Usage of Pulse Input Signal	F mode	12	None	0	-	None	No	6-2
				Feed-back	1				
				Reference	2				
EXT-13	Real Speed Direction	RealSpdDir	13	Reverse	1	-	-	-	
				Forward	2				

Chapter 5 - Parameter List

Code	Description	Keypad Display		Setting Range		Units	Factory Default	Adj. During Run	Page
		LCD	7-Segment	LCD	7-Segment				
EXT-14	Encoder Feedback Frequency	ENC FeedBack	14	* [Hz]		-	-	-	
EXT-15	Pulse Input Signal Selection	F pulse set	15	A+B A -(A+B)	0 1 2	-	A+B	No	6-2
EXT-16	Encoder Pulse Number	F pulse num	16	10 to 4096		1	1024	No	6-2
EXT-17	Filtering Time Constant for Pulse Input Signal	F filter	17	0 to 9999 [ms]		1	10 [ms]	Yes	6-2
EXT-18	Pulse Input Minimum Frequency	F pulse x1	18	0 to 100 [kHz]		0.01	0.00 [kHz]	Yes	6-2
EXT-19	Frequency Output Corresponding to Pulse Input Minimum Frequency	F freq y1	19	0 to FU1-20		0.01	0.00 [Hz]	Yes	6-2
EXT-20	Pulse Input Maximum Frequency	F pulse x2	20	0 to 100 [kHz]		0.01	10.00 [kHz]	Yes	
EXT-21	Frequency Output Corresponding to Pulse Input Maximum Frequency	F freq y2	21	0 to FU1-20		0.01	60.00 [Hz]	Yes	
EXT-22	P-Gain for 'Sub-B'	PG P-gain	22	0 to 9999		1	3000	Yes	6-2
EXT-23	I-Gain for 'Sub-B'	PG I-gain	23	0 to 9999		1	300	Yes	
EXT-24	Slip Frequency for 'Sub-B' Board	PG Slip Freq	24	0 to 200 [%]		1	100 [%]	Yes	6-2
EXT-25	P-Gain for (Sensored) Vector_SPD	ASR P-Gain	25	10 to 500 [%]		0.1	100.0 [%]	Yes	
EXT-26	I-Gain for (Sensored) Vector_SPD	ASR I-Gain	26	10 to 9999 [ms]		1	200 [ms]	Yes	
EXT-27	Forward Torque Limit	Trq + Limit	27	0 to 200 [%]		1	180 [%]	Yes	
EXT-28	Reverse Torque Limit	Trq - Limit	28	0 to 200 [%]		1	180 [%]	Yes	
EXT-30	Multi-Function Output Terminal 'Q1' Define	Q1 define	30	FDT-1 FDT-2 FDT-3 FDT-4 FDT-5 OL IOL Stall OV LV OH Lost Command Run	0 1 2 3 4 5 6 7 8 9 10 11 12	-	FDT-1	Yes	6-2

Code	Description	Keypad Display		Setting Range		Units	Factory Default	Adj. During Run	Page
		LCD	7-Segment	LCD	7-Segment				
				Stop	13				
				Steady	14				
				INV line	15				
				COMM line	16				
				Ssearch	17				
				Step pulse	18				
				Seq pulse	19				
				Ready	20				
				Trv. ACC	21				
				Trv. DEC	22				
				MMC	23				
				Zspd Dect	24				
				Torq Dect	25				
EXT-31	Multi-function Output Terminal 'Q2' Define	Q2 define	31	Same as Above		-	FDT-2	Yes	6-2
EXT-32	Multi-function Output Terminal 'Q3' Define	Q3 define	32			-	FDT-3	Yes	
EXT-34	LM (Load Meter) Output Selection	LM mode	34	Frequency	0	-	Current	Yes	6-2
				Current	1				
				Voltage	2				
				DC link Vtg	3				
				Torque	4				
EXT-35	LM Output Adjustment	LM adjust	35	100 to 200 [%]		1	100 [%]	Yes	6-2
EXT-40	AM1 (Analog Meter 1) Output Selection	AM1 mode	40	Frequency	0	-	Frequency	Yes	6-2
				Current	1				
				Voltage	2				
				DC link Vtg	3				
				Torque	4				
EXT-41	AM1 Output Adjustment	AM1 adjust	41	100 to 200 [%]		1	100 [%]	Yes	
EXT-42	AM2 (Analog Meter 2) Output Selection	AM2 mode	42	Frequency	0	-	DC link Vtg	Yes	
				Current	1				
				DC link Vtg	2				
				Torque	4				
EXT-43	AM2 Output Adjustment	AM2 adjust	43	100 to 200 [%]		1	100 [%]	Yes	
EXT-50	Speed Limit Level	Speed Limit	44	0 to 100 [%]		0.1	100 [%]	No	
EXT-51	Speed Limit Bias	Speed Bias	45	0 to 200 [%]		0.1	100 [%]	No	
EXT-52	Speed Limit Gain	Speed Gain	46	1 to 10		1	1	No	
EXT-53	Speed Limit Direction	Speed Dir	47	Reverse	0	-	Forward	No	
				Forward	1				
EXT-54	Zero Speed Detection Level	ZSD Level	48	0 to 120 [Hz]		0.01	2 [Hz]	Yes	
EXT-55	Zero Speed Detection Bandwidth	ZSD Band	49	0 to 5 [Hz]		0.01	1 [Hz]	Yes	

Chapter 5 - Parameter List

Code	Description	Keypad Display		Setting Range		Units	Factory Default	Adj. During Run	Page
		LCD	7-Segment	LCD	7-Segment				
EXT-56	Torque Detection Level	TD Level	50	0 to 150 [%]		0.1	100 [%]	Yes	
EXT-57	Torque Detection Bandwidth	TD Band	51	0 to 10 [%]		0.1	5 [%]	Yes	
EXT-99	Return Code	Not displayed	99	Not available	[PROG/ENT] or [SHIFT/ESC]	-	1	Yes	

5.6 Communication Group [COM]

COM group appears only when the corresponding Option Boards are installed. Please refer to the option manual for detail.

Code	Description	Keypad Display		Setting Range		Units	Factory Default	Adj. During Run	Page
		LCD	7-Segment	LCD	7-Segment				
COM-00	Jump to Desired Code #	Jump code	Not displayed	0 to 99	Not available	1	1	Yes	
COM-01	Option Board Type	Opt B/D	01	None Device Net Synchro PLC-GF Profibus-DP Digital-In RS485 Modbus-RTU	0 1 2 3 4 5 6 7	-	None	Yes	
COM-02	Option Mode	Opt Mode	02	None Command Freq Cmd + Freq	0 1 2 3	-	None	No	
COM-03	Option Version	Opt Version	03	-	-	-	-	No	
COM-04	Binary Option Input Selection	D-In Mode	04	8 Bit Bin 8 BCD 1% 8 BCD 1Hz 12 Bit Bin 12 BCD 0.1% 12 BCD 0.1Hz 12 BCD 1Hz	0 1 2 3 4 5 6	-	8 Bit Bin	No	
COM-05	Binary Input Filter Value	Digital Ftr	05	2-50		1	15	Yes	
COM-10	Device Net ID	MAC ID	10	0-63		1	0	Yes	
COM-11	Device Net Communication Speed	Baud Rate	11	125 kbps 250 kbps 500 kbps	0 1 2	-	125 kbps	Yes	
COM-12	Device Net Output Instance	Out Instance	12	20 21 100	0 1 2	-	20	No	

Code	Description	Keypad Display		Setting Range		Units	Factory Default	Adj. During Run	Page
		LCD	7-Segment	LCD	7-Segment				
				101	3				
COM-13	Device Net Input Instance	In Instance	13	70 71 110 111	0 1 2 3	-	70	No	
COM-17	PLC Option Station Number	Station ID	17	0 to 63		1	1	Yes	
COM-20	Profibus ID	Profi MAC ID	20	0 to 127		1	1	Yes	
COM-30	Output Number	Output Num	30	0 to 8		1	3	Yes	
COM-31	Output 1	Output 1	31	0000-57FF(HEX)			000A(HEX)	Yes	
COM-32	Output 2	Output 2	32	0000-57FF(HEX)			000E(HEX)	Yes	
COM-33	Output 3	Output 3	33	0000-57FF(HEX)			000F(HEX)	Yes	
COM-34	Output 4	Output 4	34	0000-57FF(HEX)			0000(HEX)	Yes	
COM-35	Output 5	Output 5	35	0000-57FF(HEX)			0000(HEX)	Yes	
COM-36	Output 6	Output 6	36	0000-57FF(HEX)			0000(HEX)	Yes	
COM-37	Output 7	Output 7	37	0000-57FF(HEX)			0000(HEX)	Yes	
COM-38	Output 8	Output 8	38	0000-57FF(HEX)			0000(HEX)	Yes	
COM-40	Input Number	Input Num	40	0 to 8		1	2	Yes	
COM-41	Input 1	Input 1	41	0000-57FF(HEX)			0005(HEX)	Yes	
COM-42	Input 2	Input 2	42	0000-57FF(HEX)			0006(HEX)	Yes	
COM-43	Input 3	Input 3	43	0000-57FF(HEX)			0000(HEX)	Yes	
COM-44	Input 4	Input 4	44	0000-57FF(HEX)			0000(HEX)	Yes	
COM-45	Input 5	Input 5	45	0000-57FF(HEX)			0000(HEX)	Yes	
COM-46	Input 6	Input 6	46	0000-57FF(HEX)			0000(HEX)	Yes	
COM-47	Input 7	Input 7	47	0000-57FF(HEX)			0000(HEX)	Yes	
COM-48	Input 8	Input 8	48	0000-57FF(HEX)			0000(HEX)	Yes	
COM-52	ModBus Option Selection	ModBus Mode	52	ModBus RTU			ModBus RTU	Yes	
COM-99	Return Code	Not displayed	99	Not available	[PROG/ENT] or [SHIFT/ESC]	-	1	Yes	

5.7 Application Group [APP]

Code	Description	Keypad Display		Setting Range		Units	Factory Default	Adj. During Run	Page
		LCD	7-Segment	LCD	7-Segment				
APP-00	Jump to Desired Code #	Jump code	Not displayed	0 to 99	Not available	1	1	Yes	6-2
APP-01	Application Mode Selection	App Mode	01	None Traverse MMC DRAW	0 1 2 3	-	None	No	6-2

Chapter 5 - Parameter List

Code	Description	Keypad Display		Setting Range		Units	Factory Default	Adj. During Run	Page
		LCD	7-Segment	LCD	7-Segment				
APP-02 ²⁷	Traverse Amplitude	Trv. Amp	02	0.0 to 20.0 [%]		0.1	0.0 [%]	Yes	6-2
APP-03	Traverse Scramble Amplitude	Trv. Scr	03	0.0 to 50.0 [%]		0.1	0.0 [%]	Yes	6-2
APP-04	Traverse Accel Time	Trv Acc Time	04	0 to 6000 [sec]		0.1	2.0 [sec]	Yes	6-2
APP-05	Traverse Decel Time	Trv Dec Time	05	0 to 6000 [sec]		0.1	3.0 [sec]	Yes	6-2
APP-06	Traverse Offset (Hi) Setting	Trv Off Hi	06	0.0 to 20.0 [%]		0.1	0.0 [%]	Yes	6-2
APP-07	Traverse Offset (Lo) Setting	Trv Off Lo	07	0.0 to 20.0 [%]		0.1	0.0 [%]	Yes	6-2
APP-08 ²⁸	Running Auxiliary Motor Number Display	Aux Mot Run	08	-		-	-	-	6-2
APP-09	Starting Aux. Motor Selection	Starting Aux	09	1 to 4		1	1	Yes	6-2
APP-10	Operation Time Display on Auto Change	Auto Op Time	10	-		-	-	-	6-2
APP-11	Start Frequency of Aux. Motor 1	Start freq 1	11	0 to FU1-20		0.01	49.99 [Hz]	Yes	6-2
APP-12	Start Frequency of Aux. Motor 2	Start freq 2	12	0 to FU1-20		0.01	49.99 [Hz]	Yes	
APP-13	Start Frequency of Aux. Motor 3	Start freq 3	13	0 to FU1-20		0.01	49.99 [Hz]	Yes	
APP-14	Start Frequency of Aux. Motor 4	Start freq 4	14	0 to FU1-20		0.01	49.99 [Hz]	Yes	
APP-15	Stop Frequency of Aux. Motor 1	Stop freq 1	15	0 to FU1-20		0.01	15.00 [Hz]	Yes	6-2
APP-16	Stop Frequency of Aux. Motor 2	Stop freq 2	16	0 to FU1-20		0.01	15.00 [Hz]	Yes	
APP-17	Stop Frequency of Aux. Motor 3	Stop freq 3	17	0 to FU1-20		0.01	15.00 [Hz]]	Yes	
APP-18	Stop Frequency of Aux. Motor 4	Stop freq 4	18	0 to FU1-20		0.01	15.00 [Hz]	Yes	
APP-19	Delay Time before Operating Aux Motor	Aux start DT	19	0 to 9999 [sec]		0.1	60.0 [sec]	Yes	6-2
APP-20	Delay Time before Stopping Aux Motor	Aux stop DT	20	0 to 9999 [sec]		0.1	60.0 [sec]	Yes	
APP-21	The Number of Aux Motor	Nbr Aux's	21	0 to 4		1	4	Yes	6-2
APP-22	PID Bypass Selection	Regul Bypass	22	No Yes	0 1	-	No	Yes	6-2
APP-23	Sleep Delay Time	Sleep Delay	23	0 to 9999 [sec]		0.1	60.0 [sec]	Yes	6-2
APP-24	Sleep Frequency	Sleep Freq	24	0 to FU1-20		0.01	19.00 [Hz]	Yes	6-2

²⁷ Code APP-02 through APP-07 appears only when APP-01 is set to 'Traverse'.

²⁸ Code APP-08 through APP-31 appears only when APP-01 is set to 'MMC'.

Code	Description	Keypad Display		Setting Range		Units	Factory Default	Adj. During Run	Page
		LCD	7-Segment	LCD	7-Segment				
APP-25	Wake-Up Level	WakeUp_Level	25	0 to 100 [%]		1	35 [%]	Yes	6-2
APP-26	Auto Change Mode Selection	AutoCh-Mode	26	0 to 2		1	1	Yes	6-2
APP-27	Auto Change Time	AutoEx-intv	27	00:00 to 99:00		00:01	70:00	Yes	6-2
APP-28	Auto Change Level	AutoEx-level	28	0 to 100 [%]		0.1	20 [%]	Yes	
APP-29	Inter-Lock Selection	Inter-lock	29	No Yes	0 1	-	No	Yes	6-2
APP-30	Actual Value Display	Actual Value	30	-		-	-	Yes	6-2
APP-31	Actual Value Display in Percentage	Actual Perc	31	-		-	-	Yes	6-2
APP-32 ²⁹	Draw Mode Selection	Draw Mode	32	None V1_Draw I_Draw V2_Draw	0 1 2 3	-	None	Yes	6-2
APP-33	Draw Size Setting	DrawPerc	33	0 to 150 [%]		0.1	100 [%]	Yes	6-2

²⁹ Code APP-32 through APP-33 appears only when APP-01 is set to 'Draw'.

5.8 Sub-Board Selection Guide According To Function

Code	Function Description	Sub-Board Type			
		SUB-A Board	SUB-B Board	SUB-C Board	SUB-D Board
EXT-02	Multi-Function Input Terminal 'P4'	√		√	√
EXT-03	Multi-Function Input Terminal 'P5'	√		√	√
EXT-04	Multi-Function Input Terminal 'P6'	√		√	√
EXT-05	V2 Mode Selection	√		√	√
EXT-06	Filtering Time Constant for V2 Input Signal	√		√	√
EXT-07	V2 Input Minimum Voltage	√		√	√
EXT-08	Frequency Corresponding to V2 Input Minimum Voltage	√		√	√
EXT-09	V2 Input Maximum Voltage	√		√	√
EXT-10	Frequency Corresponding to V2 Input Maximum Voltage	√		√	√
EXT-14	Usage for Pulse Input Signal		√		√
EXT-15	Pulse Input Signal Selection		√		√
EXT-16	Encoder Pulse Selection		√		√
EXT-17	Filtering Time Constant for Pulse Input Signal		√		√
EXT-18	Pulse Input Minimum Frequency		√		√
EXT-19	Frequency Output corresponding to Pulse Input Minimum Frequency		√		√
EXT-20	Pulse Input Maximum Frequency		√		√
EXT-21	Frequency Output corresponding to Pulse Input Maximum Frequency		√		√
EXT-22	P-Gain for PG Option		√		√
EXT-23	I-Gain for PG Option		√		√
EXT-24	Slip Frequency for PG Option		√		√
EXT-25	P-Gain for (Sensored) Vector_SPD				√
EXT-26	I-Gain for (Sensored) Vector_SPD				√
EXT-27	Forward Torque Limit				√
EXT-28	Reverse Torque Limit				√
EXT-30	Multi-function Output Terminal 'Q1'	√		√	√
EXT-31	Multi-function Output Terminal 'Q2'	√			√
EXT-32	Multi-function Output Terminal 'Q3'	√			
EXT-34	LM (Load Meter) Output Selection	√			
EXT-35	LM Output Adjustment	√			
EXT-40	AM1 (Analog Meter 1) Output Selection			√	
EXT-41	AM1 Output Adjustment			√	
EXT-42	AM2 (Analog Meter 2) Output Selection			√	
EXT-43	AM2 Output Adjustment			√	

Notes:

CHAPTER 6 - PARAMETER DESCRIPTION

6.1 Drive group [DRV]

DRV-00: Command Frequency or Command Torque/ Output Current (LCD)

DRV▶ Cmd. Freq*
00 0.00 Hz

F*

0.00

Factory Default: 0.00 Hz

0.00

* In Torque mode : LCD display - Cmd. Trq
7 Segment - r

- In FU2-39[Control Mode Selection], 4 (Sensorless_T) 6 (Vector_TRQ) is torque mode.
- DRV-00 [Command Frequency or Command Torque] has two functions.

1) Digital frequency setting

- When DRV-04 [Frequency or Torque Mode] is set to 0 (KeyPad-1) or 1 (KeyPad-2), command freq is not settable above FU1-20 [Maximum Frequency].

2) Monitoring function setting

- Command frequency displayed during stop
- Output current/frequency displayed during run.

Analog/digital frequency command setting in DRV-04 [Frequency or Torque Mode]:

- DRV-04 [Frequency or Torque Mode] is set to 2 (V1),3 (I) or 4 (V1+I), frequency command is set via I/O-01~10 [Analog Frequency command/Torque]. Refer to I/O-01~10 for detail description.
- DRV-16 [Speed Unit Selection] is set to 1 (Rpm), speed is displayed in Rpm.
- If FU2-39 is set to 4 (Sensorless_T) or 6 (Vector_TRQ), speed is displayed as the percent[%] to the rated torque. Torque command is settable in DRV-04 [Frequency or Torque Mode].

* Factory default setting = 100[%] (Up to 150[%] settable)

● Setting the DRV-04 [Frequency or Torque Mode]

(Note: In torque mode, speed unit is automatically displayed in [%])

Setting	DRV-04	Parameter Name	Programming Description
0	KeyPad-1	Digital freq. command	1. In DRV-00, press the [PROG] key. 2. Enter the desired freq. 3. Press the [ENT] key to write the new value into memory.
1	KeyPad-2		1. In DRV-00, press the [PROG] key. 2. Press the [↑(Up)] or [↓(Down)] key to set the desired freq., while the inverter keeps running. 3. Press the [ENT] key to write the new value into memory.
2	V1	Analog freq. command	Control terminal "V1" Voltage analog input (0 to 0V) See the description of I/O-01~05.
3	I		Control terminal "I" Current analog input (4 to 20mA) See the description of I/O-06~10.
4	V1+I		Control terminal "V1"+"I" (0-10V/4-20mA) Analog input See the description of I/O-01~10.

- Command Freq/Torque setting via "V1" input terminal when set DRV-04 [Frequency/Torque mode] to 2 (V1) or 4 (V1+I)

Code	Default setting	Setting range
I/O-01	10 [msec]	0 ~ 10000 [msec]
I/O-02	0 [V]	0 ~ 10 [V]
I/O-03	0 [Hz]	0 ~ Max. freq
I/O-04	10 [V]	0 ~ 10 [V]
I/O-05	60 [Hz]	0 ~ Max freq

Code	Keypad Display	Parameter Name
I/O-01	V1 filter	Filter Time Constant for V1 Signal Input
I/O-02	V1 volt x1	V1 Input Minimum Voltage
I/O-03	V1 freq y1	Frequency Corresponding to V1 Input Minimum Voltage
I/O-04	V1 volt x2	V1 Input Maximum Voltage
I/O-05	V1 freq y2	Frequency Corresponding to V1 Input Maximum Voltage

➡ Important : Increase I/O-01-[Filter Time Constant for V1 Signal Input] if the V1 signal is affected by noise causing unstable operation. Increasing this value makes response time slower.

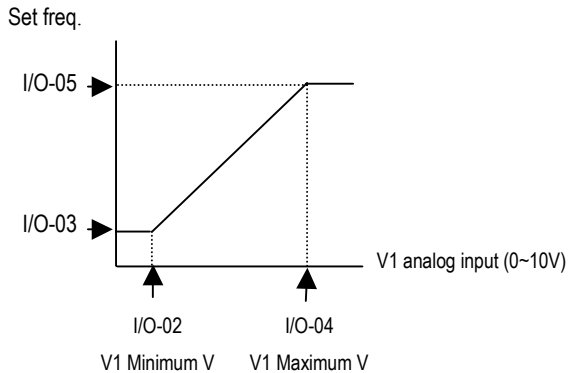

I/O-06~10 [Analog Current Input “I” Signal adjustment]

- Command Freq/Torque setting via “I” input terminal when set DRV-04 [Frequency/Torque mode] to 3 (I) or 4 (V1+I)

Code	Default setting	Setting range
I/O-06	10 [msec]	0 ~ 10000 [msec]
I/O-07	4 [mA]	0 ~ 20 [mA]
I/O-08	0 [Hz]	0 ~ Max. freq
I/O-09	20 [mA]	0 ~ 20 [mA]
I/O-10	60 [Hz]	0 ~ Max. freq

Code	Keypad display	Parameter Name
I/O-06	I filter	Filter time constant for I signal Input
I/O-07	I curr x1	I Input Minimum Current
I/O-08	I freq y1	Frequency Corresponding to I Input Minimum Current
I/O-09	I curr x2	I Input Maximum Current
I/O-10	I freq y2	Frequency Corresponding to I Input Maximum Current

➡ Important : Increase I/O-06-[Filter time constant for I signal Input] if the I signal is affected by noise causing unstable operation. Increasing this value makes response time slower.

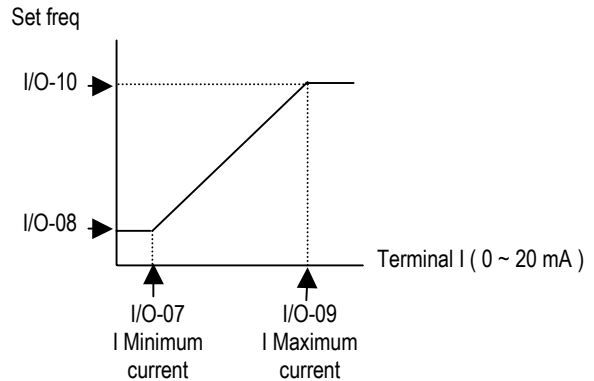

Related parameters : DRV-04 [Frequency or Torque Mode]
 DRV-16 [Speed Unit Selection]
 FU1-20 [Maximum Frequency]
 FU2-39 [Control Mode Selection]
 I/O-1~10 [Analog Frequency command/Torque]

DRV-01: Acceleration Time

DRV▶ Acc. time	01	10.0
01 10.0 sec		
Factory Default: 10.0 sec		10.0

DRV-02: Deceleration Time

DRV▶ Dec. time	02	20.0
02 20.0 sec		
Factory Default: 20.0 sec		20.0

The inverter targets the FU2-70 when accelerating or decelerating. When the FU2-70 is set to “Maximum Frequency”, the acceleration time is the time taken by the motor to reach FU1-20 from 0 Hz. The deceleration time is the time taken by the motor to reach 0 Hz from FU1-20 [Maximum Frequency].

When the FU2-70 is set to ‘Delta Frequency’, the acceleration and deceleration time is the time taken to reach a targeted frequency (instead the maximum frequency) from a frequency.

The acceleration and deceleration time can be changed to a preset transient time via multi-function inputs. By setting the multi-function inputs (P1, P2, P3) to ‘XCEL-L’, ‘XCEL-M’, ‘XCEL-H’ respectively, the Accel and Decel time set in I/O-25 to I/O-38 are applied according to the binary inputs of the P1, P2, P3.

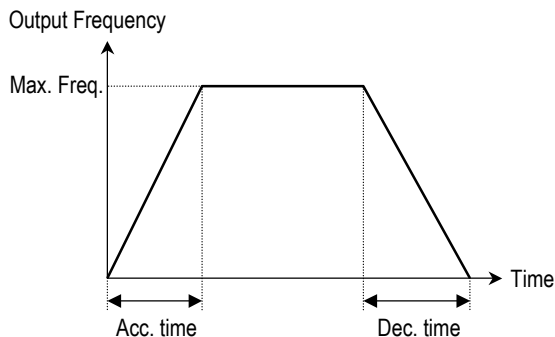

- Related Functions:**
- FU1-20 [Max freq]
 - FU2-70 [Reference freq. for Accel/Decel]
 - FU2-71 [Accel/Decel time scale]
 - I/O-12 to I/O-14 [Multi-function input terminal P1, P2, P3]
 - I/O-25 to I/O-38 [Acc/Dec time for step frequency]
- FU2-70: Selects the frequency to be targeted for acceleration and deceleration. [Max Freq, Delta Freq]
 - FU2-71: Selects the time scale. [0.01, 0.2, 1]
 - I/O-12 to I/O-14: Sets the terminal function of P1, P2, P3 terminal inputs.
 - I/O-25 to I/O-38: Presets the Accel/Decel time activated via multifunction inputs (P1, P2, P3)

► Note: I/O-12 to I/O-14: Sets the terminal function of P1, P2, P3 terminal inputs.

Code	LCD display	Description	XCEL-H	XCEL-M	XCEL-L	Factory setting
DRV-01	Acc time	Acc time 0	0	0	0	10 sec
DRV-02	Dec time	Dec time 0	0	0	0	20 sec
I/O-25	ACC-1	Acc time 1	0	0	1	20 sec
I/O-26	DEC-1	Dec time 1	0	0	1	20 sec
I/O-27	ACC-2	Acc time 2	0	1	0	30 sec
I/O-28	DEC-2	Dec time 2	0	1	0	30 sec
I/O-29	ACC-3	Acc time 3	0	1	1	40 sec
I/O-30	DEC-3	Dec time 3	0	1	1	40 sec
I/O-31	ACC-4	Acc time 4	1	0	0	50 sec
I/O-32	DEC-4	Dec time 4	1	0	0	50 sec
I/O-33	ACC-5	Acc time 5	1	0	1	40 sec
I/O-34	DEC-5	Dec time 5	1	0	1	40 sec
I/O-35	ACC-6	Acc time 6	1	1	0	30 sec
I/O-36	DEC-6	Dec time 6	1	1	0	30 sec
I/O-37	ACC-7	Acc time 7	1	1	1	20 sec
I/O-38	DEC-7	Dec time 7	1	1	1	20 sec

FU2-71 [Accel/Decel time scale]

- Set the Accel / Decel time unit.

Setting	Unit	Description
0	0.01 sec	Minimum 0 sec settable Maximum 60 sec settable
1	0.1 sec	Minimum 0 sec settable Maximum 600 sec settable (Factory setting)
2	1 sec	Minimum 0 sec settable Maximum 6000 sec settable*

* Up to 6000 sec setting is available via LE-200 keypad.

DRV-03: Drive Mode (Run/Stop Method)

DRV▶ Drive mode	03	1
03 Keypad		
Factory Default: Fx/Rx-1		1

Select the source of run/stop command.

Setting Range		Description
LCD	7-Seg	
Keypad	0	Run/Stop is controlled by Keypad.
Fx/Rx-1	1	Control Terminals FX, RX and 5G control Run/Stop. (Method 1)
Fx/Rx-2	2	Control Terminals FX, RX and 5G control Run/Stop. (Method 2)

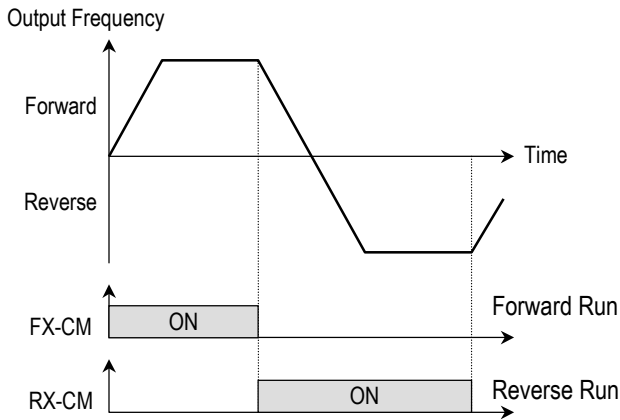

[Drive Mode: 'Fx/Rx-1']

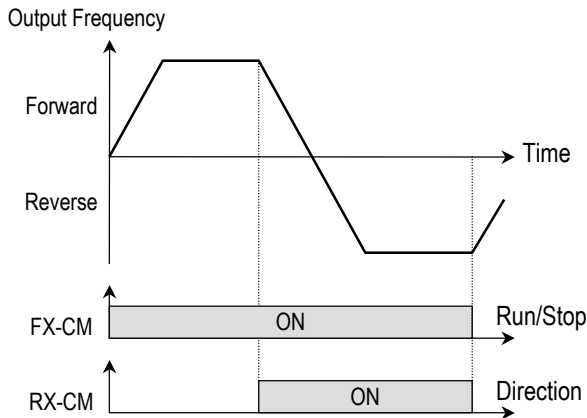

[Drive Mode: 'Fx/Rx-2']

DRV-04: Frequency or Torque Mode (Frequency / Torque Setting Method)

DRV▶ Freq mode*	04	0
04 Keypad-1		
Factory Default:	Keypad-1	0

* In Torque mode : LCD display: "Trque mode"
7 Segment: "04"

- If the DRV-04 [Frequency or Torque Mode] is set to 2 (V1), 3 (I), 4 (V1+I), see the description of I/O-01~10 [Analog Voltage/Current input signal adjustment].
- If FU2-39 is set to 4 (Sensorless_T) or 6 (Vector_TRQ), speed is displayed as the percent[%] to the rated torque. Torque command is settable in DRV-04 [Frequency or Torque Mode].
- DRV-04 setting value is separately saved according to which control mode (Speed or Torque) is selected in FU2-39 [Control mode selection].

Setting Range		Description
LCD	7-Seg	
Keypad-1	0	Frequency is set at DRV-00. The frequency is changed by pressing PROG key and entered by pressing ENT key. The inverter does not output the changed frequency until the ENT key is pressed.
Keypad-2	1	Frequency is set at DRV-00. Press PROG key and then by pressing the ▲ , ▼ key, the inverter immediately outputs the changed frequency. Pressing the ENT key saves the changed frequency.
V1	2	Input the frequency reference (0-10V) to the "V1" control terminal. Refer to the I/O-01 to I/O-05 for scaling the signal.
I	3	Input the frequency reference (4~20mA) to the "I" control terminal. Refer to the I/O-06 to I/O-10 for scaling the signal.
V1+I	4	Input the frequency reference (0-10V, 4~20mA) to the "V1", "I" control terminals. The 'V1' signal overrides the 'I' signal.

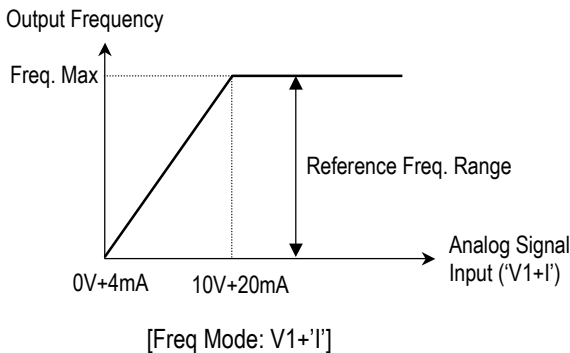
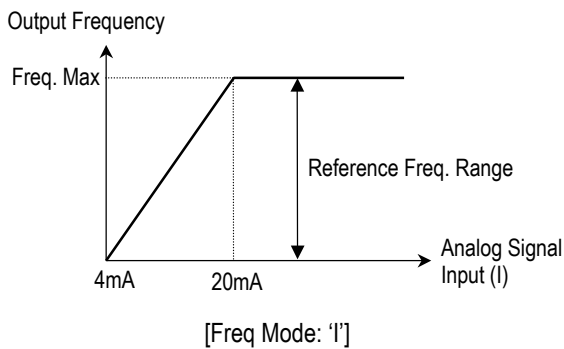
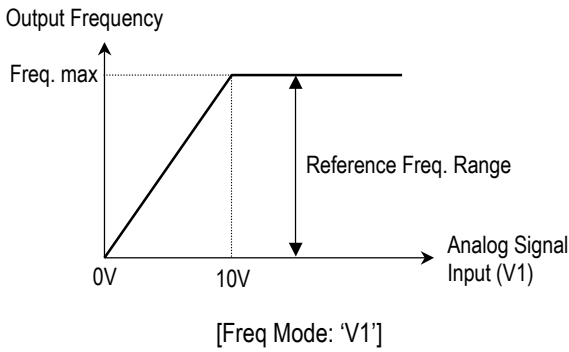

Related functions: DRV-00 [Digital Command Frequency or Command Torque]
 FU2~39 [Control Mode Selection]
 I/O-01~10 [Analog Voltage/Current input signal adjustment]

DRV-05 ~ DRV-07: Step Frequency 1 ~ 3

DRV▶ Step freq-1	05	10.00
05 10.00 Hz		

Factory Default: 10.00 Hz **10.00**

DRV▶ Step freq-2	06	20.00
06 20.00 Hz		

Factory Default: 20.00 Hz **20.00**

DRV▶ Step freq-3	07	30.00
07 30.00 Hz		

Factory Default: 30.00 Hz **30.00**

The inverter outputs preset frequencies set in these codes according to the multi-function terminals configured as 'Speed-L', 'Speed-M' and 'Speed-H'. The output frequencies are decided by the binary combination of P1, P2, P3 configured in I/O-12 to I/O-17. Refer to the following table for the preset frequency outputs.

Binary Combination of P1, P2, P3			Output Frequency	Step Speed
Speed-L	Speed-M	Speed-H		
0	0	0	DRV-00	Speed 0
1	0	0	DRV-05	Speed 1
0	1	0	DRV-06	Speed 2
1	1	0	DRV-07	Speed 3

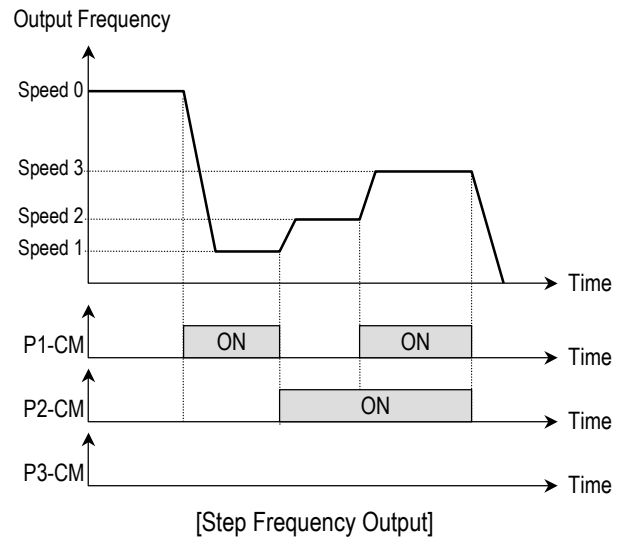

- Related Functions:** I/O-12 to I/O-14 [Reference Inputs]
I/O-17 [Filtering Time Constant]
I/O-21 to I/O-21 [Step Frequency 4~7]
- I/O-01 to I/O-10: Scaling the analog input signals (V1 and I) for frequency reference.
 - I/O-17: Adjusts the response sensibility of the input terminal to eliminate contact noise.
 - I/O-21 to I/O-24: Sets the step frequency from 4 to 7.

Note: The frequency setting method of 'Speed 0' is decided by DRV-04.

DRV-08: Output Current

DRV▶ Current
08 0.0 A

08

0.0

Factory Default: 0.0 A 0.0

This code displays the output current of the inverter in RMS.

DRV-09: Motor Speed

DRV▶ Speed
09 0rpm

09

0

Factory Default: 0rpm 0

This code displays the motor speed in RPM while the motor is running.
Use the following equation to scale the mechanical speed using FU2-74 [Gain for Motor Speed display] if you want to change the motor speed display to rotation speed (r/min) or mechanical speed (m/min).

$$\text{Motor speed} = 120 * (F/P) * \text{FU2-74}$$

Where, F= Output Frequency and P= the Number of Motor Poles

DRV-10: DC Link Voltage

DRV▶ DC link vtg
10 ---- V

10

Factory Default: ---- V ----

This code displays the DC link voltage inside the inverter.

DRV-11: User Display Selection

DRV▶ User disp
11 Out 0.0 V

11

0.0

Factory Default: 0.0 V 0.0

This code displays the parameter selected in FU2-73 [User Display]. There are types of parameters in FU2-73: Voltage, Watt and Torque.

DRV-12: Fault Display

DRV▶ Fault
12 None

12

n0n

Factory Default: None n0n

This code displays the current fault (trip) status of the inverter. Use the **PROG**, **▲** and **▼** key before pressing the **RESET** key to check the fault content(s), output frequency, output current, and whether the inverter was accelerating, decelerating, or in constant speed at the time of the fault occurred. Press the **ENT** key to exit. The fault content will be stored in FU2-01 to FU2-05 when the **RESET** key is pressed. For more detail, please refer to Chapter 7.

[Fault Contents]

Fault (Trip)	Keypad display	
	LCD	7-Segment
Over-Current 1	Over Current 1	OC
Over-Voltage	Over Voltage	OV
External Trip Input A	External-A	EXTA
Emergency Stop (Not Latched)	BX	BX
Low-Voltage	Low Voltage	LV
Fuse Open	Fuse Open	FUSE
Ground Fault	Ground Fault	GF
Over-Heat on Heat sink	Over Heat	OH
Electronic Thermal Trip	E-Thermal	ETH
Over-Load Trip	Over Load	OLT
Inverter H/W Fault - EEP Error - ADC Offset - WDOG Error - In-Phase Open	HW-Diag	HW
External Trip Input B	External-B	EXTB
Over-Current 2	Arm Short	ASHT
Option Error	Option	OPT

Output Phase Loss	Phase Open	PO
Inverter Over-Load	Inv. OLT	IOLT

Note: There are WDOG error, EEP error, and ADC Offset for the inverter Hardware Fault - the inverter will not reset when H/W fault occurs. Repair the fault before turning on the power.

Note: Only the highest-level fault will be displayed when multiple faults occur.

- Related Functions:** FU2-01 to FU2-05 [Previous Fault History]
FU2-06 [Erase Fault History]
- FU2-01 to FU2-05: There are up to 5 faults saved.
 - FU2-06: Erases the faults saved in FU2-01 to FU2-05.

DRV-13: Motor Direction Set (7-Segment Keypad)

13 **0**

Factory Default: **0**

This code sets the motor direction when using the 7-Segment keypad.

7-Segment Display	Description
0	Run to forward direction
1	Run to reverse direction

DRV-14: Command/Output Frequency Display (LCD Keypad)

DRV▶TAR 0.00Hz
14 OUT 0.00Hz

Factory Default: 0.00Hz

This code shows the Command (Target) Frequency set in DRV00 and inverter Output Frequency.

DRV-15: Reference/Feedback Frequency Display (LCD Keypad)

DRV▶REF 0.00Hz
15 FBK 0.00Hz

Factory Default: 0.00Hz

This code shows the Reference Frequency and Feedback Frequency while PID operation.

This code appears only when 'PID' is selected in FU2-47.

DRV-16: Hz/Rpm Display

DRV▶ Fault **12** **n0n**
12 None

Factory Default: None **n0n**

Set this parameter to 0 [Hz] to display frequency, or to 1[Rpm] to display speed Related code

Related Functions: Changing the Hz/Rpm display affects the following parameter display.

- DRV-00, 05, 06, 07, 14
- FU1-20, 21,22, 24, 25, 32
- FU2-32
- I/O-03, 05, 08, 10, 20, 21, 22, 23, 24, 42, 43
- EXT-08, 10

DRV-20: FU1 Group Selection (7-Segment keypad)

DRV-21: FU2 Group Selection (7-Segment keypad)

DRV-22: I/O Group Selection (7-Segment keypad)

DRV-23: EXT Group Selection (7-Segment keypad)

DRV-24: COM Group Selection (7-Segment keypad)

DRV-25: APP Group Selection (7-Segment keypad)

Select the desired group and press the **PROG/ENT** key to move into the desired group. The parameter in the group can be read and written after moving into the desired group.

Notes:

6.2 Function 1 Group [FU1]

FU1-00: Jump to Desired Code

FU1▶ Jump code
00 1

Factory Default: 1

Jumping directly to any parameter code can be accomplished by entering the desired code number. This code is available only with LCD keypad.

FU1-03: Run Prevention

FU1▶ Run prev.
03 None

03

0

Factory Default: None 0

This function prevents reverse operation of the motor. This function may be used for loads that rotate only in one direction such as fans and pumps.

Setting Range		Description
LCD	7-Seg	
None	0	Forward and Reverse run is available.
Forward Prev	1	Forward run is prevented.
Reverse Prev	2	Reverse run is prevented.

FU1-05: Acceleration Pattern

FU1-06: Deceleration Pattern

FU1▶ Acc. pattern
05 Linear

05

0

Factory Default: Linear 0

FU1▶ Dec. pattern
06 Linear

06

0

Factory Default: Linear 0

Different combinations of acceleration and deceleration patterns can be selected according to the application.

Setting Range		Description
LCD	7-Seg	
Linear	0	This is a general pattern for constant torque applications.
S-curve	1	This pattern allows the motor to accelerate and decelerate smoothly. The actual acceleration and deceleration time takes longer- about 40% than the time set in DRV-01 and DRV-02. This setting prevents shock during acceleration and deceleration, and prevents objects from swinging on conveyors or other moving equipment.
U-curve	2	This pattern provides more efficient control of acceleration and deceleration in typical winding machine applications.
Minimum	3	The inverter makes shorten the acceleration time by accelerating with a current rate of about 150% of its rated current and reduces the deceleration time by decelerating with a DC voltage rate of 95% of its over-voltage trip level. <i>Appropriate application:</i> When the maximum capability of the inverter and the motor are required. <i>Inappropriate application:</i> The current limit function may operate for a long period of time for loads that have high inertia such as fans.
Optimum	4	The inverter accelerates with a current rate of about 120% of its rated current and decelerates with a DC voltage rate of 93% of its over-voltage trip level.

- ☞ **Note:** In case of selecting the 'Minimum' or 'Optimum', the DRV-01 and DRV-02 is ignored.
- ☞ **Note:** 'Minimum' and 'Optimum' functions operate normally when the load inertia is less than 10 times compared to the motor inertia. (FU2-37)
- ☞ **Note:** 'Optimum' is useful when the motor capacity is smaller than the inverter capacity.
- ☞ **Note:** 'Minimum' and 'Optimum' functions are not appropriate for down operation in an elevator application.

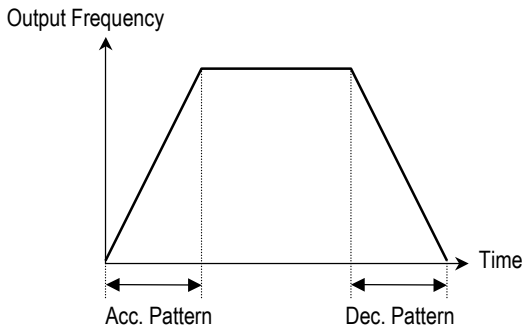

[Accel/Decel Pattern: 'Linear']

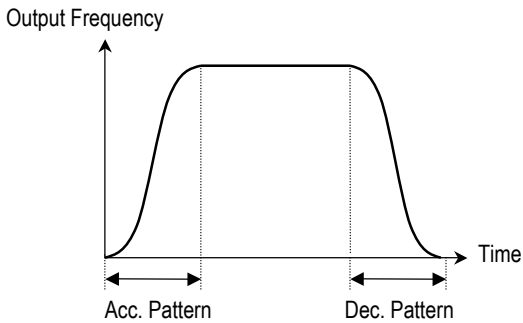

[Accel/Decel Pattern: 'S-curve']

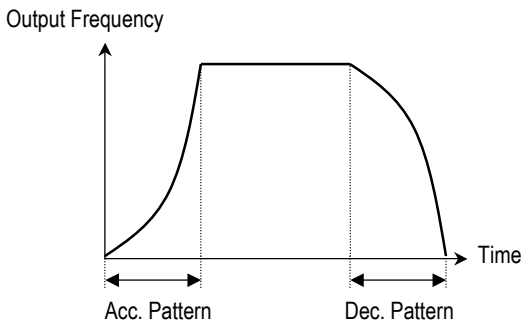

[Accel/Decel Pattern: 'U-curve']

FU1-07: Stop Mode

FU1▶ Stop mode
07 Decel

07

0

Factory Default: Decel

0

Sets the stopping method for the inverter.

Setting Range		Description
LCD	7-Seg	
Decel	0	Inverter stops by the deceleration pattern.
Dc-brake	1	Inverter stops with DC injection braking. Inverter outputs DC voltage when the frequency reached the DC injection braking frequency set in FU1-08 during decelerating.
Free-run (Coast to stop)	2	Inverter cuts off its output immediately when the stop signal is commanded.

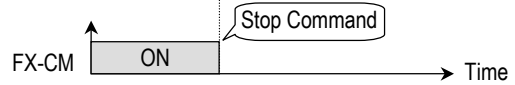
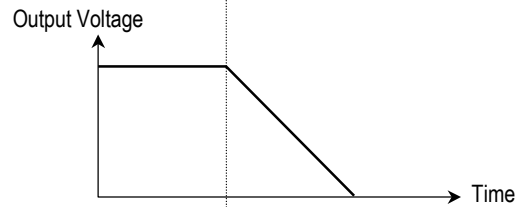
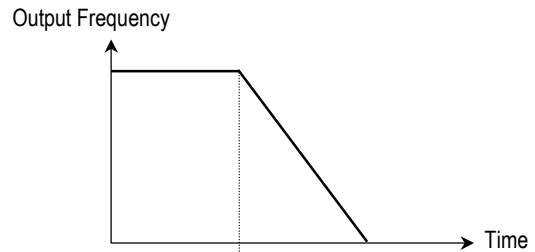

[Stop Mode: 'Decel']

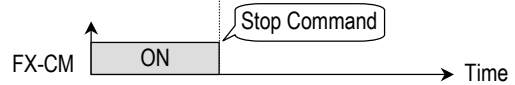
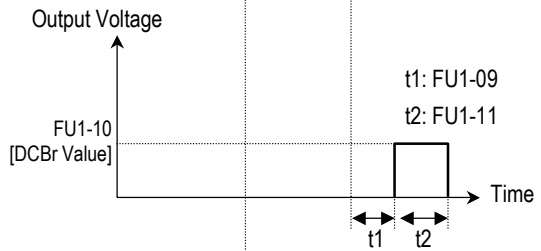
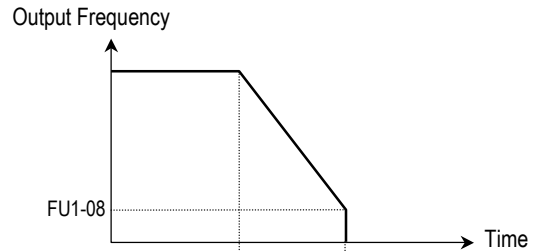

[Stop Mode: 'Dc-brake']

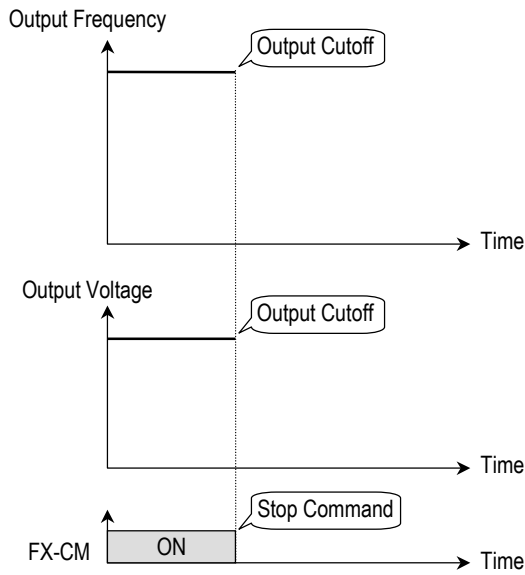

[[Stop Mode: 'Free-run']

FU1-08: DC Injection Braking Frequency
FU1-09: DC Injection Braking On-delay Time
FU1-10: DC Injection Braking Voltage
FU1-11: DC Injection Braking Time

FU1▶ DcBr freq	08	5.00
08 5.00 Hz		
Factory Default:	5.00 Hz	5.00

FU1▶ DcBlk time	09	0.10
09 0.10 sec		
Factory Default:	0.10 sec	0.10

FU1▶ DcBr value	10	50
10 50 %		
Factory Default:	50 %	50

FU1▶ DcBr time	11	1.0
11 1.0 sec		
Factory Default:	1.0 sec	1.0

By introducing a DC voltage to the motor windings this function stops the motor immediately. Selecting 'DC-Brake' in FU1-07 activates FU1-08 through FU1-11.

FU1-08 [DC Injection Braking Frequency] is the frequency at which the inverter starts to output DC voltage during deceleration.

FU1-09 [DC Injection Braking On-delay Time] is the inverter output blocking time before DC injection braking.

FU1-10 [DC Injection Braking Voltage] is the DC voltage applied to the motor and is based on FU2-33 [Rated Current of Motor].

FU1-11 [DC Injection Braking Time] is the time the DC current is applied to the motor.

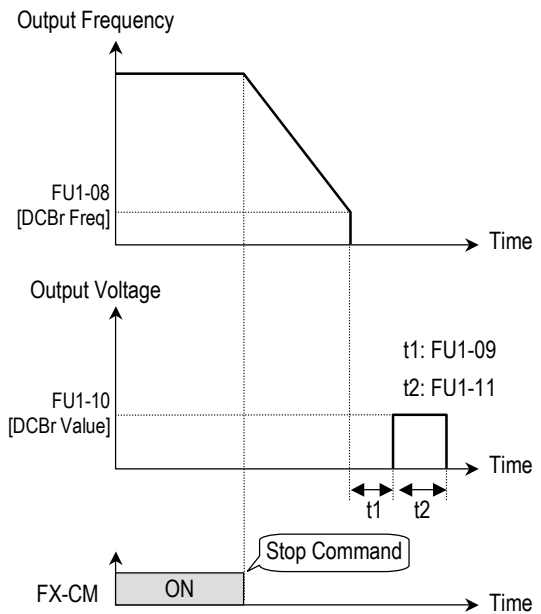

[DC Injection Braking Operation]

FU1-12: Starting DC Injection Braking Time
FU1-13: Starting DC Injection Braking Time

FU1▶ DcSt value	12	50
12 50 %		

Factory Default: 50 % **50**

FU1▶ DcSt time	13	0.0
13 0.0 sec		

Factory Default: 0.0 sec **0.0**

Inverter holds the starting frequency for Starting DC Injection Braking Time. It outputs DC voltage to the motor for FU1-13 [Starting DC Injection Braking Time] with the FU1-12 [Starting DC Injection Braking Voltage] before accelerating.

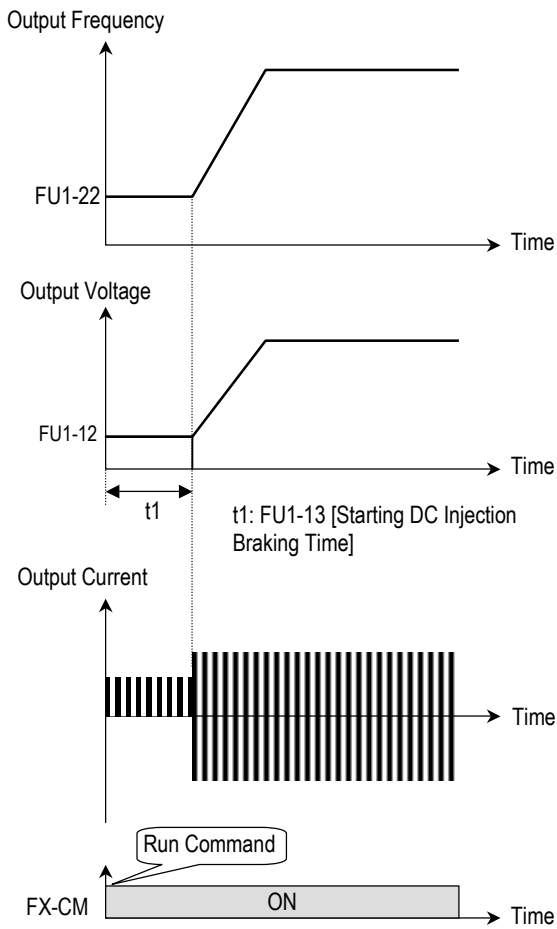

[Starting DC Injection Braking Operation]

Related Functions: FU2-33 [Rated Current of Motor]
 ■ FU2-33: the DC current is limited by this parameter.

☞ **Note:** The DC injection braking function does not function when either FU1-12 or FU1-13 is set to "0".

☞ **Note:** FU1-12 [Starting DC Injection Braking Voltage] is also used as the DC Injection Braking Voltage for the multifunction input when the multifunction input is set to "DC braking".

FU1-14: Pre-excitation Time

FU1▶ PreExTime	14	1.0
14 1.0 sec		

Factory Default: 1.0 sec **1.0**

To set the time for pre-excitation (Flux gain time) before starting Vector or Sensorless Vector control

- After FU1-14 [Pre-excitation Time] elapses the motor starts acceleration,

Code	LCD display	Factory setting	Setting range
FU1-14	PreExTime	1 [sec]	0 ~ 60 [sec]

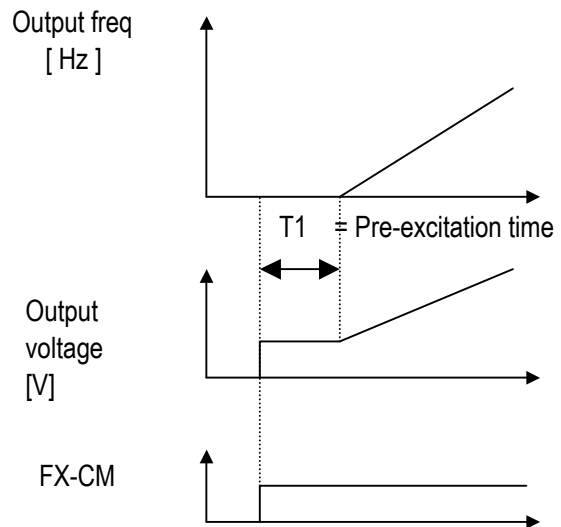

Related function : FU2-34 [No Load Motor Current (RMS)]
 FU1-16 [Pre-excitation Current]

FU1-15: Hold Time

FU1▶ Hold Time	15	1000
15 1000 ms		
Factory Default:	1000 ms	1000

To set the time to maintain holding torque at zero speed and stop the operation in a shortest time during Vector_SPD mode operation

- The inverter runs to maintain speed 0 for the hold time in Vector_SPD mode and decelerates to stop after the hold time elapse.

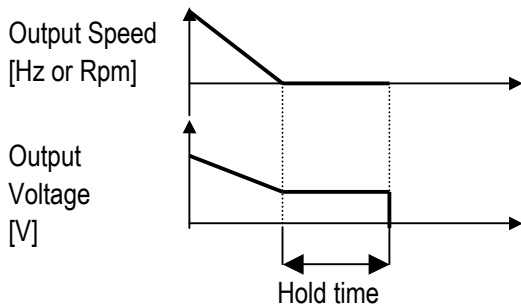

→ Operation method during Hold Time:
 FU1-7[Stop mode] Decel: speed zero control
 FU1-7[Stop mode] DC-brake

FU1-16: Pre-excitation Current

FU1▶ Flux Force	16	100.0
16 100.0 %		
Factory Default:	100.0 %	100.0

FU1-16 [Pre-excitation Current] is applied during FU1-14. When the motor magnetic flux increases to match the rated magnetic flux, pre-excitation current starts to decrease. When the motor magnetic flux reaches to the rated magnetic flux, the pre-excitation current matches the rated pre-excitation current.

Code	LCD display	Factory setting	Setting range
FU1-16	Flux Force	100 [%]	100 ~ 500 [%]

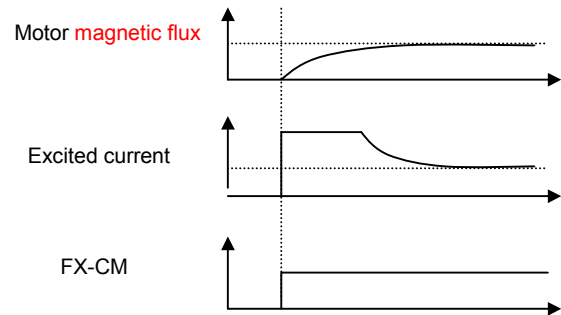

Related Functions: FU2-34 [No Load Motor Current (RMS)]
 FU1-14 [Pre-excitation Time]

FU1-20: Maximum Frequency
FU1-21: Base Frequency
FU1-22: Starting Frequency

FU1▶ Max freq	20	60.00
20 60.00 Hz		
Factory Default:	60.00 Hz	60.00

FU1▶ Base freq	21	60.00
21 60.00 Hz		
Factory Default:	60.00 Hz	60.00

FU1▶ Start freq	22	0.50
22 0.50 Hz		
Factory Default:	0.50 Hz	0.50

FU1-20 [Maximum Frequency] is the maximum output frequency of the inverter. Make sure this maximum frequency does not exceed the rated speed of the motor. FU1-21 [Base Frequency] is the frequency where the inverter outputs its rated voltage. In case of using a 50Hz motor, set this to 50Hz. FU1-22 [Starting Frequency] is the frequency where the inverter starts to output its voltage.

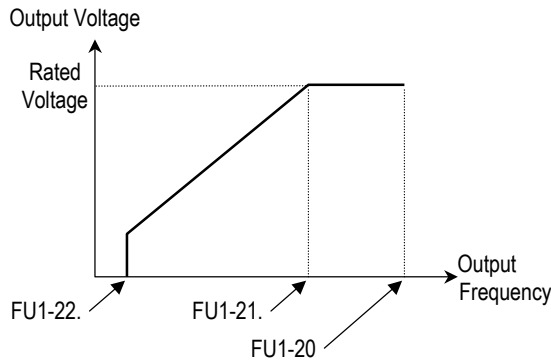

Note: If the command frequency is set lower than the starting frequency, inverter does not output voltage to motor.

FU1-23: Frequency Limit Selection
FU1-24: Low Limit Frequency
FU1-25: High Limit Frequency

FU1▶ Freq limit 23 --- No ---	23	0
Factory Default: No		0

FU1▶ F-limit Lo 24 0.50 Hz	24	0.50
Factory Default: 0.50 Hz		0.50

FU1▶ F-limit Hi 25 60.00 Hz	25	60.00
Factory Default: 60.00 Hz		60.00

FU1-23 selects the limits for the inverter operating frequency. If FU1-23 is set to 'Yes', inverter operates within the upper and lower limit setting. The inverter operates at the upper or the lower limit when the frequency reference is outside the frequency limit range.

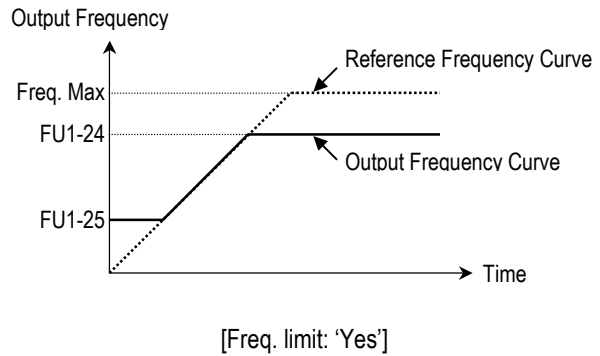

Note: Frequency limit does not work during accelerating and decelerating.

FU1-26: Manual/Auto Boost Selection
FU1-27: Torque Boost in Forward Direction
FU1-28: Torque Boost in Reverse Direction

FU1▶ Torque boost 26 Manual	26	0
Factory Default: Manual		0

FU1▶ Fwd boost 27 2.0 %	27	2.0
Factory Default: 2.0 %		2.0

FU1▶ Rev boost 28 2.0 %	28	2.0
Factory Default: 2.0 %		2.0

This function is used to increase the starting torque at low speed by increasing the output voltage of the inverter. If the boost value is set too high than required, it may cause the motor flux to saturate, causing over-current trip. Increase the boost value when there is excessive distance between inverter and motor.

[Manual Torque Boost]: The forward and reverse torque boost is set separately in FU1-27 and FU1-28.

Note: The torque boost value is the percentage of inverter rated voltage.

Note: When FU1-29 [Volts/Hz Pattern] is set to 'User V/F', this function does not work.

☞ **Note:** When FU2-40 [Control Mode] is set to 'Sensorless', the torque boost value is the rate per thousand of inverter rated voltage.

[Auto Torque Boost]: Inverter outputs high starting torque by automatic boosting according to the load.

☞ **Note:** Auto torque boost is only available for the 1st motor. Manual torque boost must be used for the 2nd motor.

☞ **Note:** The auto torque boost value is added to the manual torque boost value.

☞ **Note:** Auto torque boost is available only when FU2-40 [Control Mode] is set to 'V/F'.

☞ **Note:** Conduct Auto tuning in FU2-41 [Auto tuning] to use Auto torque boost effectively.

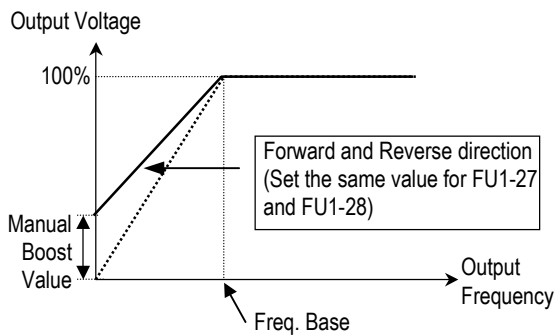

[Constant Torque Loads: Conveyor, Moving Equip. etc.]

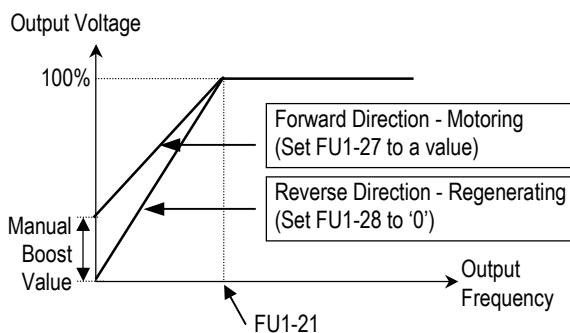

[Ascending and Descending Loads: Parking, Hoist etc.]

Related Functions: FU1-29 [Volts/Hz Pattern]
FU2-40 [Control Mode selection]

FU1-29: Volts/Hz Pattern

FU1▶ V/F pattern	29	0
29 Linear		
Factory Default:	Linear	0

This is the pattern of voltage/frequency ratio. Select the proper V/F pattern according to the load. The motor torque is dependent on this V/F pattern.

[Linear] pattern is used where constant torque is required. This pattern maintains a linear volts/frequency ratio from zero to base frequency. This pattern is appropriate for constant torque applications.

[Square] pattern is used where variable torque is required. This pattern maintains squared volts/hertz ratio. This pattern is appropriate for fans, pumps, etc.

[User V/F] pattern is used for special applications. Users can adjust the volts/frequency ratio according to the application. This is accomplished by setting the voltage and frequency, respectively, at four points between starting frequency and base frequency. The four points of voltage and frequency are set in FU1-30 through FU1-37.

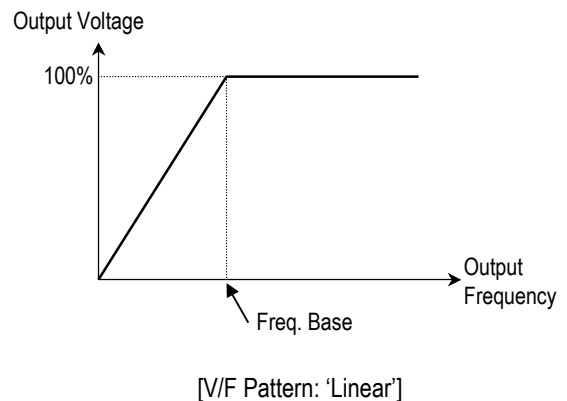

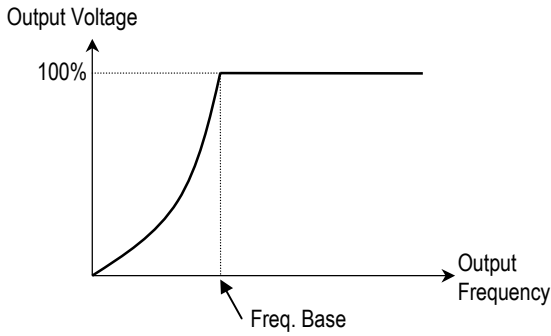

[V/F Pattern: 'Square']

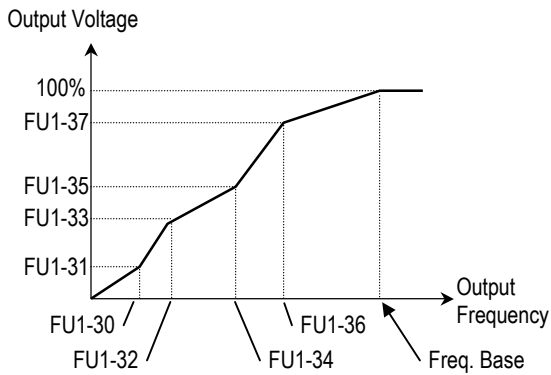

[V/F Pattern: 'User V/F']

FU1-30 ~ FU1-37: User V/F Frequency and Voltage

FU1▶ User freq 1 30 15.00 Hz	30	15.00
--------------------------------------	-----------	--------------

Factory Default:	15.00 Hz	15.00
------------------	----------	--------------

FU1▶ User volt 1 31 25 %	31	25
----------------------------------	-----------	-----------

Factory Default:	25 %	25
------------------	------	-----------

-
-
-

FU1▶ User freq 4 36 60.00 Hz	36	15.00
--------------------------------------	-----------	--------------

Factory Default:	60.00 Hz	15.00
------------------	----------	--------------

FU1▶ User volt 4 37 100 %	37	100
-----------------------------------	-----------	------------

Factory Default:	100 %	100
------------------	-------	------------

These functions are available only when 'User V/F' is selected in FU1-29 [V/F pattern]. Users can make the custom V/F pattern by setting four points between FU1-22 [Starting Frequency] and FU1-21 [Base Frequency].

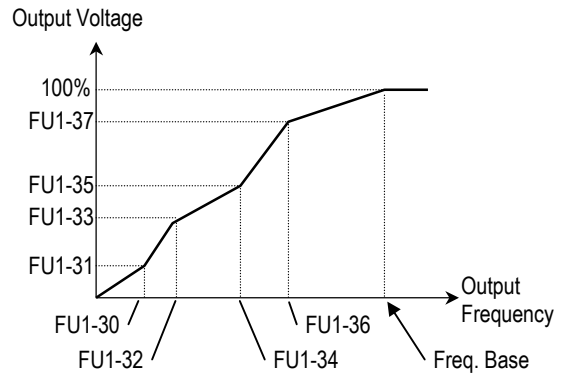

[User V/F]

Note: When the 'User V/F' is selected, the torque boost of FU1-26 through FU1-28 is ignored.

Related Functions: FU1-21 [Base Frequency]
FU1-22 [Starting Frequency]
FU1-29 [Volts/Hz Pattern]

FU1-38: Output Voltage Adjustment

FU1▶ Volt control	38	100
38 100.0 %		
Factory Default:	100.0 %	100

This function is used to adjust the output voltage of the inverter. This is useful when using a motor with a lower rated voltage than the main input voltage. When this is set at 100%, inverter outputs its rated voltage.

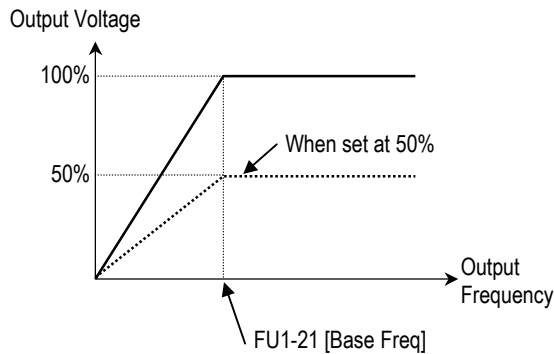

Note: The inverter output voltage does not exceed the main input voltage, even though FU1-38 is set at 110%.

FU1-39: Energy Save Level

FU1▶ Energy save	39	0
39 0 %		
Factory Default:	0 %	0

This function is used to reduce the output voltage in applications that do not require high torque and current at its steady speed. The inverter reduces its output voltage after accelerating to the reference frequency (steady speed) if the energy save level is set at 20%. This function may cause over-current trip due to the lack of output torque in a fluctuating load. This function does not work with 0% set point value.

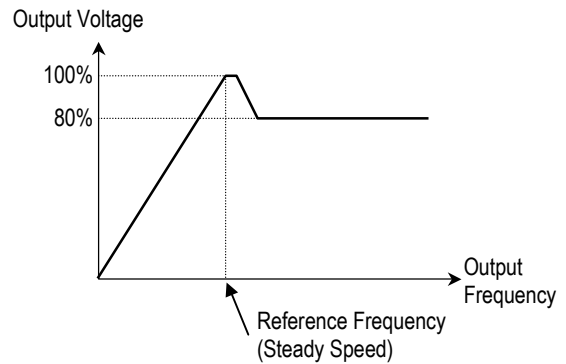

[When Energy Save Level is set at 20%]

- Note:** This function is not recommended for a large load or for an application that need frequent acceleration and deceleration.
- Note:** This function does not work when 'Sensorless' is selected in FU2-40 [Control Mode].

FU1-50: Electronic Thermal (Motor i²t) Selection
FU1-51: Electronic Thermal Level for 1 Minute
FU1-52: Electronic Thermal Level for Continuous
FU1-53: Electronic Thermal Characteristic (Motor type) selection

These functions are to protect the motor from overheating without using additional thermal overload relay. Inverter calculates the temperature rising of the motor using several parameters and determines whether or not the motor is overheated. Inverter will turn off its output and display a trip message when the electronic thermal feature is activated.

FU1▶ ETH select	50	0
50 --- No ---		
Factory Default:	No	0

This function activates the ETH parameters by setting 'Yes'.

FU1▶ ETH 1min	51	150
51 150 %		
Factory Default:	150 %	150

This is the reference current when the inverter determines

the motor has overheated. It trips in one minute when 150% of rated motor current established in FU2-33 flows for one minute.

Note: The set value is the percentage of FU2-33 [Rated Motor Current].

FU1▶ ETH cont 52	100 %	52	100
Factory Default:	100 %		100

This is the current at which the motor can run continuously. Generally, this value is set to '100%' and which means the rated motor current set in FU2-33. This value must be set less than FU1-52 [ETH 1min].

Note: The set value is the percentage of FU2-33 [Rated Motor Current].

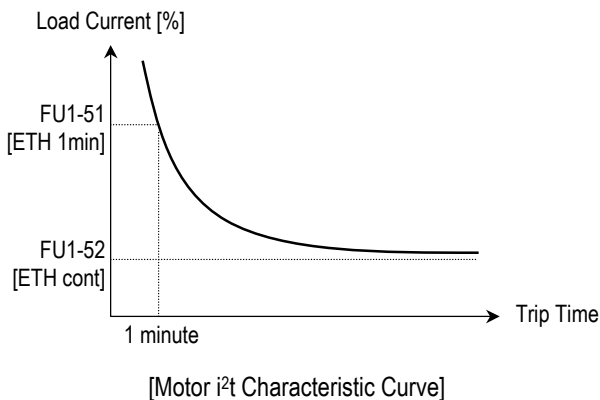

FU1▶ Motor type 53	Self-cool	53	0
Factory Default:	Self-cool		0

To make the ETH function (Motor i²t) work correctly, the motor cooling method must be selected correctly according to the motor.

[Self-cool] is a motor that has a cooling fan connected directly to the shaft of the motor. Cooling effects of a self-cooled motor decrease when a motor is running at low speeds. The motor current is derated as the motor speed decreases.

[Forced-cool] is a motor that uses a separate motor to

power a cooling fan. As the motor speed changes, the cooling effects do not change.

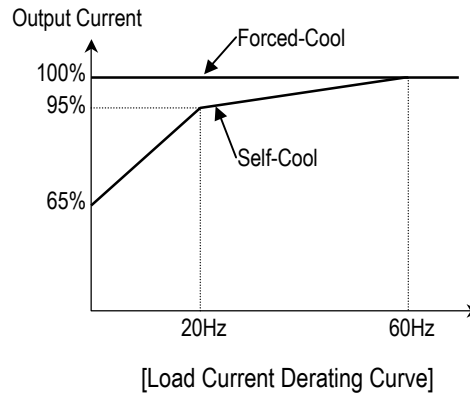

Note: Despite the motor current changing frequently due to load fluctuation or acceleration and deceleration, the inverter calculates the i²t and accumulates the value to protect the motor.

Related Functions: FU2-33 [Rated Motor Current]

FU1-54: Overload Warning Level
FU1-55: Overload Warning Time

FU1▶ OL level 54	150 %	54	150
Factory Default:	150 %		150

FU1▶ OL time 55	10.0 sec	55	10.0
Factory Default:	10.0 sec		10.0

The inverter generates an alarm signal when the output current has reached the FU1-54 [Overload Warning Level] for the FU1-55 [Overload Warning Time]. The alarm signal persists for the FU1-55 even if the current has become the level below the FU1-54.

Multi-function output terminal (AXA-AXC) is used as the alarm signal output. To output the alarm signal, set I/O 44 [Multifunction Auxiliary Contact Output] to 'OL'.

Note: Inverter is not tripped by this function.

Note: The set value is the percentage of FU2-33 [Rated

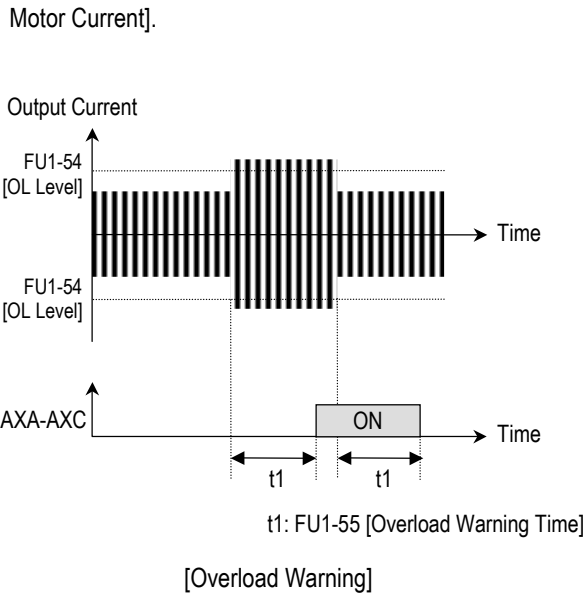

Related Functions: FU2-33 [Rated Motor Current]
I/O-44 [Multi-function Auxiliary Contact Output]

FU1-56: Overload Trip Selection
FU1-57: Overload Trip Level
FU1-58: Overload Trip Delay Time

FU1▶ OLT select	56	1
56 --- Yes ---		

Factory Default:	Yes	1
------------------	-----	----------

FU1▶ OLT level	57	180
57 180 %		

Factory Default:	180 %	180
------------------	-------	------------

FU1▶ OLT time	58	60.0
58 60.0 sec		

Factory Default:	60.0 sec	60.0
------------------	----------	-------------

Inverter cuts off its output and displays fault message when the output current persists over the FU1-57 [Overload Trip Level] for the time of FU1-58 [Overload Trip Time]. This function protects the inverter and motor from abnormal load conditions.

➡ **Note:** The set value is the percentage of FU2-33 [Rated Motor Current].

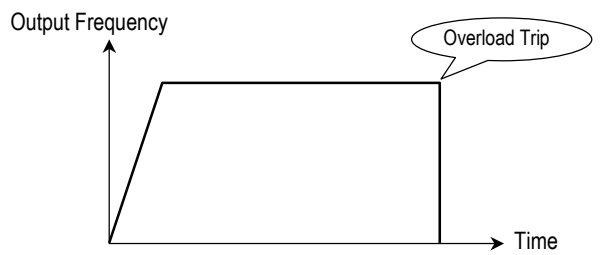
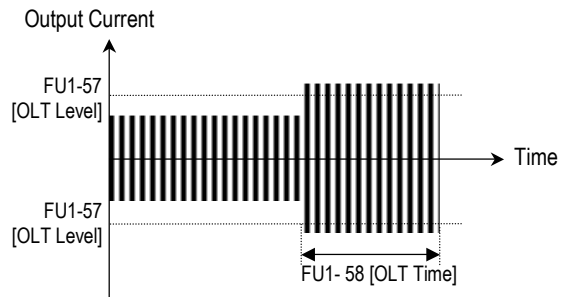

[Overload Trip Operation]

Related Functions: FU2-33 [Rated Motor Current]

FU1-59: Stall Prevention Mode Selection (Bit set)
FU1-60: Stall Prevention Level

FU1▶ Stall prev.	59	000
59 000		

Factory Default:	000	000
------------------	-----	------------

This bit set parameter follows the conventions used in I/O-15 and I/O-16 to show the ON (bit set) status.

FU1▶ Stall level	60	180
60 180 %		

Factory Default:	180 %	180
------------------	-------	------------

This function is used to prevent the motor from stalling by reducing the inverter output frequency until the motor current decreases below the stall prevention level. This function can be selected for each mode of acceleration, steady speed, and deceleration via bit combination.

Note: The set value is the percentage of FU2-33 [Rated Motor Current].

FU1-59 [Stall Prevention Mode Selection]

Setting Range			FU1-59	Description
3rd bit	2nd bit	1st bit		
0	0	1	001	Stall Prevention during Acceleration
0	1	0	010	Stall Prevention during Steady Speed
1	0	0	100	Stall Prevention during Deceleration

When FU1-59 is set to '111', stall prevention works during accelerating, steady speed and decelerating.

Note: The acceleration and deceleration time may take longer than the time set in DRV-01, DRV-02 when Stall Prevention is selected.

Note: If stall prevention status persists, inverter may stop during acceleration.

Related Functions: FU2-33 [Rated Motor Current]

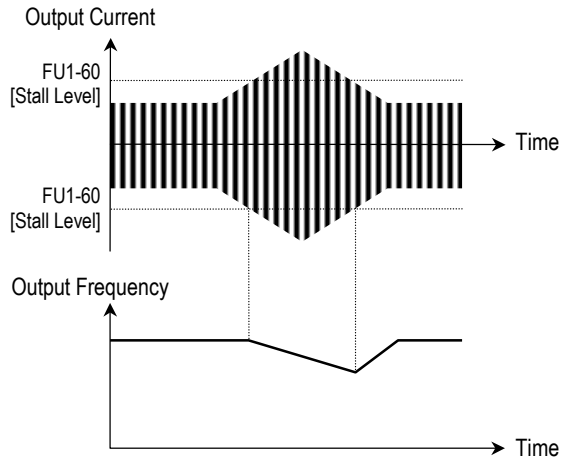
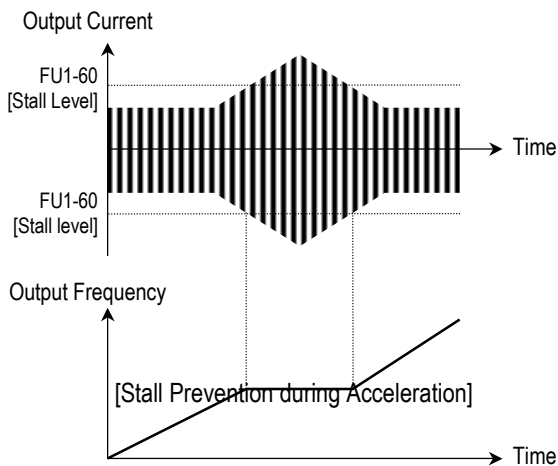

[Stall Prevention during Steady Speed]

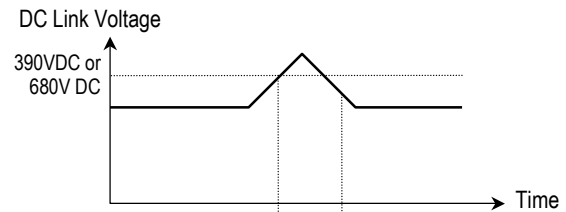

[Stall Prevention during Deceleration]

FU1-99: Return Code (7-Segment Keypad)

99 **0**

Factory Default: **0**

This code is used to exit a group when using a 7-segment keypad. After pressing **PROG/ENT** key, set the value to '1' and press the **PROG/ENT** key again to exit.

Related Functions: FU2-99 [Return Code]
I/O-99 [Return Code]
EXT-99 [Return Code]
COM-99 [Return Code]

Notes:

6.3 Function 2 Group [FU2]

FU2-00: Jump to desired code

FU2▶ Jump code
00 1

Factory Default: 1

Jumping directly to any parameter code can be accomplished by entering the desired code number. This code is available only with LCD keypad.

- FU2-01: Previous Fault History 1
- FU2-02: Previous Fault History 2
- FU2-03: Previous Fault History 3
- FU2-04: Previous Fault History 4
- FU2-05: Previous Fault History 5
- FU2-06: Erase Fault History

FU2▶ Last trip-1
01 None 01 0

Factory Default: None 0

-
-
-

FU2▶ Last trip-5
05 None 05 0

Factory Default: None 0

This code displays up to five previous fault (trip) status of the inverter. Use the **PROG**, **▲** and **▼** key before pressing the **RESET** key to check the fault content(s), output frequency, output current, and whether the inverter was accelerating, decelerating, or in constant speed at the time of the fault occurred. Press the **ENT** key to exit. The fault content will be stored in FU2-01 through FU2-05 when the **RESET** key is pressed. For more detail, please refer to Chapter 7.

[Fault Contents]

Fault (Trip)	Keypad Display	
	LCD	7-Segment
Over-Current 1	Over Current 1	OC
Over-Voltage	Over Voltage	OV
External Trip Input A	External-A	EXTA
Emergency Stop (Not Latched)	BX	BX
Low-Voltage	Low Voltage	LV
Fuse Open	Fuse Open	FUSE
Ground Fault	Ground Fault	GF
Over-Heat on Heat sink	Over Heat	OH
Electronic Thermal Trip	E-Thermal	ETH
Over-Load Trip	Over Load	OLT
Inverter H/W Fault - EEP Error - ADC Offset - WDOG Error - In-Phase Open	HW-Diag	HW
External Trip Input B	External-B	EXTB
Over-Current 2	Arm Short	ASHT
Option Error	Option	OPT
Output Phase Loss	Phase Open	PO
Inverter Over-Load	Inv. OLT	IOLT

- ☞ **Note:** There are WDOG error, EEP error, and ADC Offset for the inverter Hardware Fault, and the inverter will not reset when H/W fault occurs. Repair the fault before turning on the power.
- ☞ **Note:** When multiple faults occur, only the highest-level fault will be displayed.

Related Functions: DRV-12 [Fault Display] displays current fault status.

FU2▶ Erase trips
06 --- No --- 06 0

Factory Default: No 0

This function erases all fault histories of FU2-01 to FU-05 from the memory.

FU2-07: Dwell Frequency

FU2-08: Dwell Time

FU2▶ Dwell freq 07	5.00 Hz	07	5.00
-----------------------	---------	-----------	-------------

Factory Default:	5.00 Hz	5.00
------------------	---------	-------------

FU2▶ Dwell time 08	0.0 sec	08	0.0
-----------------------	---------	-----------	------------

Factory Default:	0.0 sec	0.0
------------------	---------	------------

This function is used to output torque in an intended direction. It is useful in hoisting applications to get enough torque before a releasing mechanical brake. If the dwell time is set at '0', this function is not available. In dwell operation, the inverter outputs AC voltage not a DC voltage.

Note: DC Injection Braking does not output torque to an intended direction. It is just to hold the motor.

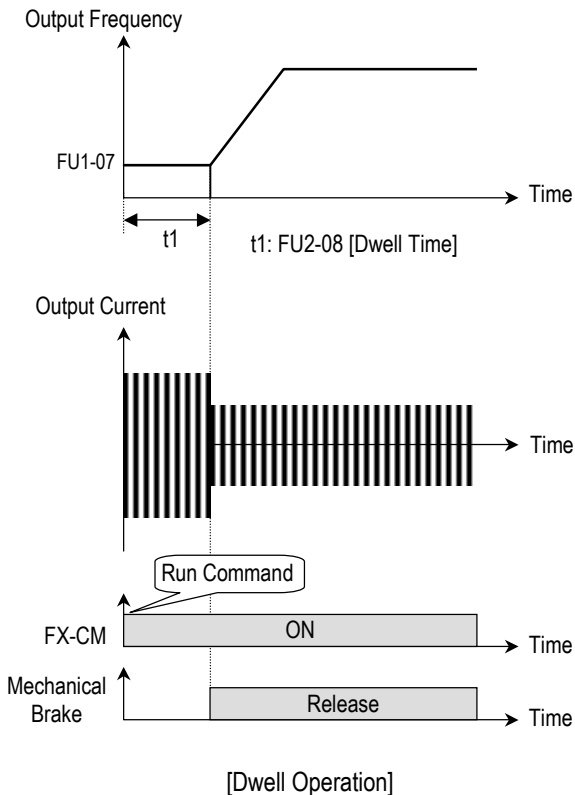

FU2-10 ~ FU2-16: Frequency Jump

FU2▶ Jump freq 10 --- No ---	10	0
---------------------------------	-----------	----------

Factory Default:	No	0
------------------	----	----------

FU2▶ jump lo 1 11 10.00 Hz	11	10.00
-------------------------------	-----------	--------------

Factory Default:	10.00 Hz	10.00
------------------	----------	--------------

FU2▶ jump Hi 1 12 15.00 Hz	12	15.00
-------------------------------	-----------	--------------

Factory Default:	15.00 Hz	15.00
------------------	----------	--------------

FU2▶ jump lo 3 15 30.00 Hz	15	30.00
-------------------------------	-----------	--------------

Factory Default:	30.00 Hz	30.00
------------------	----------	--------------

FU2▶ jump Hi 3 16 35.00 Hz	16	35.00
-------------------------------	-----------	--------------

Factory Default:	35.00 Hz	35.00
------------------	----------	--------------

To prevent undesirable resonance and vibration on the structure of the machine, this function locks out the potential resonance frequency from occurring. Three different jump frequency ranges may be set. This avoidance of frequencies does not occur during accelerating or decelerating. It only occurs during continuous operation.

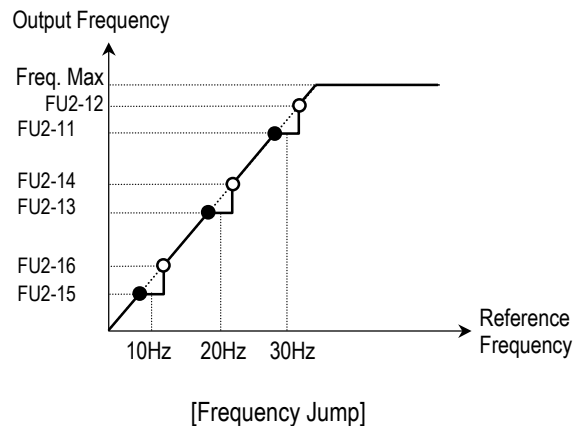

☞ **Note:** When the reference frequency is set inside the jump frequency, the output frequency goes to the frequency marked by “●” symbol.

☞ **Note:** If one frequency jump range is required, set all ranges to the same range.

FU2-17: Start Curve for S-Curve Accel/Decel Pattern
FU2-18: End Curve for S-Curve Accel/Decel Pattern

FU2▶ Start Curve **17** **40**
 17 40 %

Factory Default: 40% **40**

FU2▶ End Curve **18** **40**
 18 40 %

Factory Default: 40% **40**

This parameter is used to adjust the Accel and Decel pattern when 'S-Curve' is selected in FU1-05 and FU1-06 respectively. To use this function, the Reference Frequency for Accel and Decel set in FU2-70 should be set to 'Delta freq'.

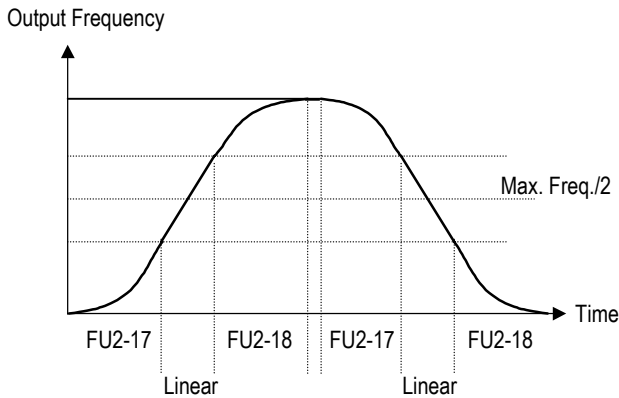

[S0Curve Adjustment]

$$\text{Actual Accel Time} = \text{DRV-01} + (\text{DRV-01} * \text{FU2-17})/2 + (\text{DRV-01} * \text{FU2-18})/2$$

$$\text{Actual Decel Time} = \text{DRV-02} + (\text{DRV-02} * \text{FU2-17})/2 + (\text{DRV-02} * \text{FU2-18})/2$$

Ex) If DRV-10: 1 sec, FU2-17: 40%, FU2-18: 20%,
 Actual Accel Time = 1 sec + (1sec*0.4)/2 + (1sec*0.2)/2 = 1.3 sec

FU2-19: Input/Output Phase Loss Protection (Bit Set)

FU2▶ Trip select **19** **00**
 19 00

Factory Default: 00 **00**

This function is used to cut the inverter output off in case of phase loss in either input power or inverter output.

FU2-19 [Phase Loss Protection Select]

Setting Range		FU2-19	Description
2 nd bit	1 st bit		
0	0	00	Phase loss protection does not work
0	1	01	Protect inverter from output phase loss
1	0	10	Protect inverter from input phase loss
1	1	11	Protect inverter from input and output phase loss

Related Functions: FU2-22 to FU2-25 [Speed Search]

FU2-20: Power ON Start Selection

FU2▶ Power-on run **20** **0**
 20 --- No ---

Factory Default: No **0**

If FUN-20 is set to 'No', restart the inverter by cycling the FX or RX terminal to CM terminal after power has been restored.

If FUN-20 is set to 'Yes', the inverter will restart after power is restored. If the motor is rotating by inertia at the time power is restored, the inverter may trip. To avoid this trip, use 'Speed Search' function by setting FU2-22 to '1xxx'.

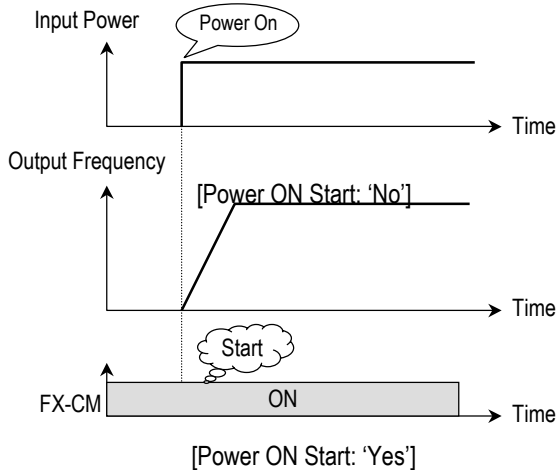
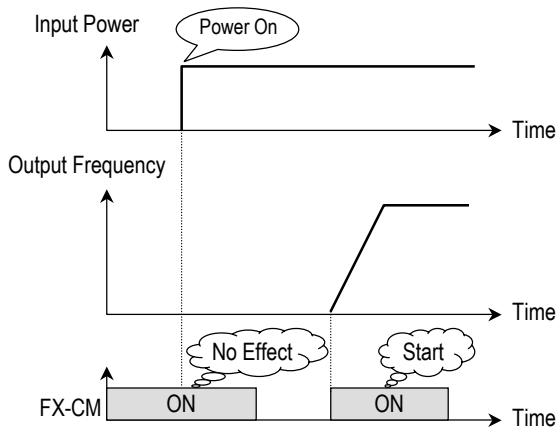

Note: In case of using 'Power ON Start' to 'Yes', make sure to utilize appropriate warning notices to minimize the potential for injury or equipment damage.

Related Functions: FU2-22 ~ FU2-25 [Speed Search]

FU2-21: Restart After Fault Reset

FU2▶ RST restart	21	0
21 --- No ---		

Factory Default:	No	0
------------------	----	----------

If FU2-21 is set to 'Yes', inverter will restart after the RST (reset) terminal has been reset a fault.
 If FU2-21 is set to 'No', restart the inverter by cycling the FX or RX terminal to CM terminal after the fault has been

reset. If the motor is rotating by inertia at the time power is restored, the inverter may trip. To avoid this trip, use 'Speed Search' function by setting FU2-22 to 'xx1x'.

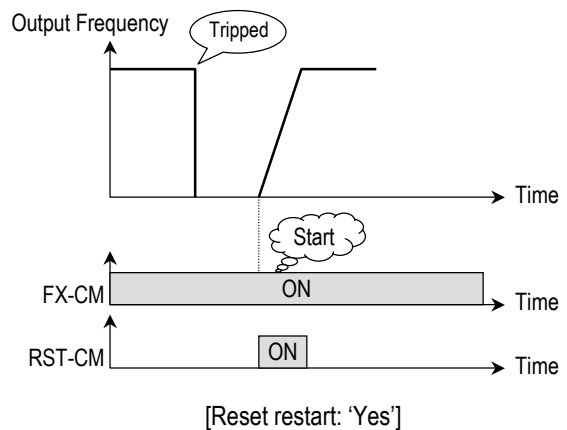
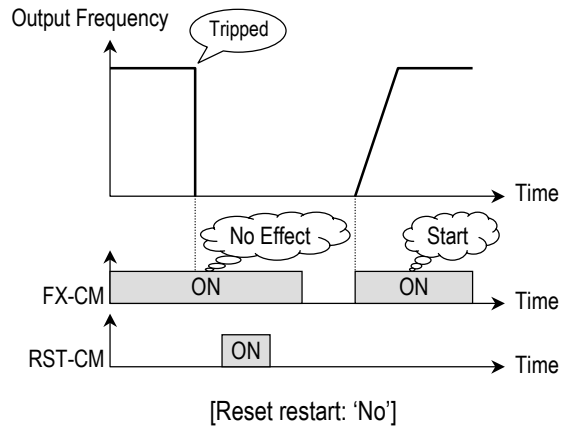

Note: In case of using 'Reset Restart' to 'Yes', make sure to utilize appropriate warning notices to minimize the potential for injury or equipment damage.

Related Functions: FU2-22 ~ FU2-25 [Speed Search]

FU2-22: Speed Search Selection (Bit Set)

FU2-23: Current Limit Level During Speed Search
FU2-24: P Gain During Speed Search
FU2-25: I Gain During Speed Search

FU2▶ Speed Search	22	0000
22 0000		

Factory Default:	0000	0000
------------------	------	-------------

FU2▶ SS Sup-Curr 23	100 %	23	100
------------------------	-------	-----------	------------

Factory Default: 100 % **100**

FU2▶ SS P-gain 24	100	24	100
----------------------	-----	-----------	------------

Factory Default: 100 **100**

FU2▶ SS I-gain 25	1000	25	1000
----------------------	------	-----------	-------------

Factory Default: 1000 **100**

This function is used to permit automatic restarting after Power ON, Fault Reset, and Instant Power Failure without waiting for the motor to stop.

The speed search gain should be set after considering the inertia moment (GD^2) and magnitude of torque of the load. FU2-37 [Load Inertia] must be set at the correct value to make this function operate correctly.

FU2-22 [Speed Search Select]

Setting Range				Description
4 th bit	3 rd bit	2 nd bit	1 st bit	
0	0	0	0	Speed search function does not work
0	0	0	1	Speed search during Accelerating
0	0	1	0	Speed search during a Fault Reset restarting (FU2-21) and Auto restarting (FU2-26)
0	1	0	0	Speed search during Instant Power Failure restarting.
1	0	0	0	Speed search during Power ON starting (FU2-20)

When FU2-22 is set to '1111', Speed Search works for all conditions.

FU2-22 [Speed Search Selection] selects the speed search function.

FU2-23 [Current Limit Level] is the current that the inverter limits its current rise during speed searching. (The set value is the percentage of FU2-33 [Rated Motor Current])

FU2-24 [P Gain] is the proportional gain used for speed search. Set this value according to load inertia set in FU2-37.

FU2-25 [I Gain] is the Integral gain used for speed search. Set this value according to load inertia set in FU2-37.

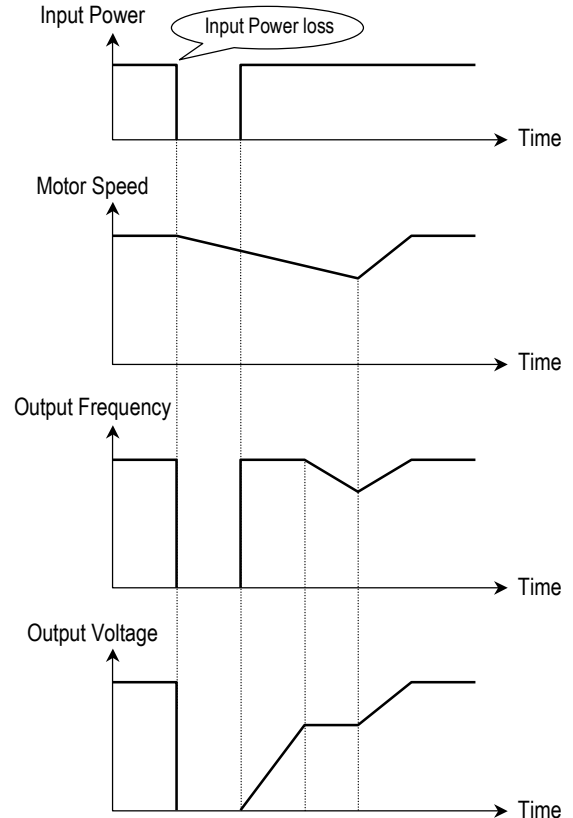

[Speed Search Operation]

Related Functions: FU2-20 [Power ON Start]
 FU2-21 [Restart after Fault Reset]
 FU2-26 ~ FU2-27 [Auto Restart]
 FU2-30 ~ FU2-37 [Motor Parameters]

FU2-26: Number of Auto Restart Attempt
FU2-27: Delay Time Before Auto Restart

FU2▶ Retry number 26	0	26	0
-------------------------	---	-----------	----------

Factory Default: 0 **0**

FU2▶ Retry delay 27	1.0 sec	27	1.0
------------------------	---------	-----------	------------

Factory Default: 1.0 sec **1.0**

This function is used to allow the inverter to reset itself for a selected number of times after a fault has occurred. The inverter can restart itself automatically when a fault occurs. To use the speed search function during auto restarting set FU2-22 to 'xx1x'. See FU2-22 ~ FU2-25.

When an under voltage (LV) fault, inverter disable (BX) or Arm short occurs, the drive does not restart automatically.

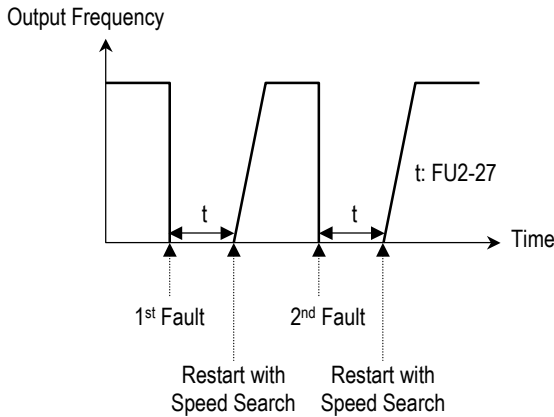

Note: Inverter decreases the retry number by one as a fault occurs. When restarted without a fault during 30 seconds, the inverter increases the retry number by one.

FU2-28: Speed search hold time

FU2▶ SS blk time	28	1.0
28 1.0 sec		
Factory Default:	1.0 sec	1.0

The inverter starts speed search function after the preset time t1 elapses. Set the desired time for inverter to restart the previous operation using Speed search function. Speed search function [FU2-22] is activated automatically during exchanging function.

Code	Keypad display	Description	Factory setting	Setting Range
FU2-28	SS blk time	Speed search hold time during speed search	1 sec	0 ~ 60 sec

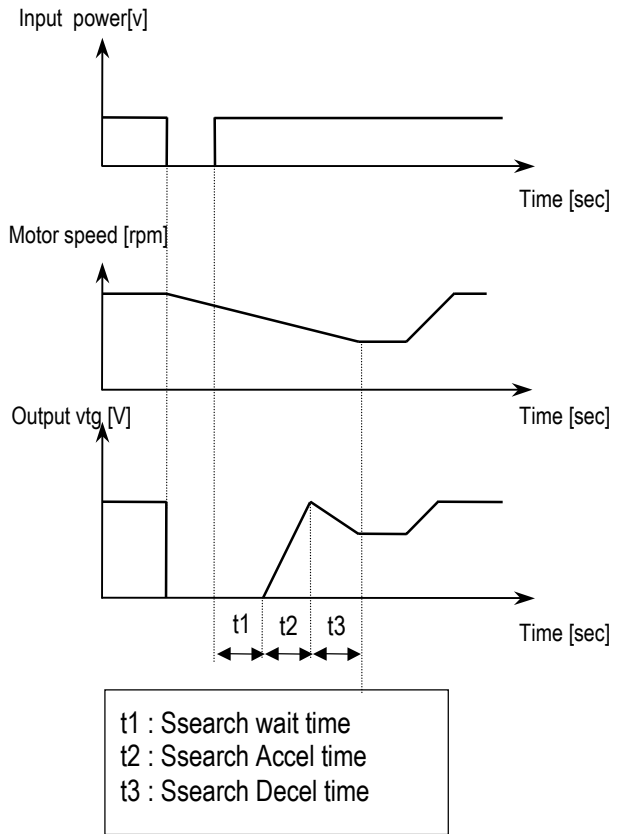

Note: This parameter is not valid when low voltage (LV) fault or instant power loss (within 15msec) occurs.

- FU2-30: Rated Motor Selection**
- FU2-31: Number of Motor Pole**
- FU2-32: Rated Motor Slip**
- FU2-33: Rated Motor Current**
- FU2-34: No Load Motor Current**
- FU2-36: Motor Efficiency**
- FU2-37: Load Inertia**

If you do not set these values, inverter will use its default values.

FU2▶ Motor select	30	0
30 0.75kW		
Factory Default:	0.75 kW	0
(This value is set according to the model number before shipping)		

This parameter sets the motor capacity. Other motor related parameters are changed automatically according to

motor capacity. The motor related parameters are FU2-32 [Rated Motor Slip], FU2-33 [Rated Motor Current], FU2-34 [No Load Motor Current], FU2-42 [Stator Resistance], FU2-43 [Rotor Resistance], and FU2-44 [Leakage Inductance].

If you know the motor parameters, set the values in the relevant codes for better control performance.

FU2▶ Pole number 31	4	31	4
------------------------	---	-----------	----------

Factory Default:	4	4
------------------	---	----------

This is used to display the motor speed. If you set this value to 2, inverter will display 3600 rpm instead 1800rpm at 60Hz output frequency. (See motor nameplate)

FU2▶ Rated-Slip 32	3.00 Hz	32	3.00
-----------------------	---------	-----------	-------------

Factory Default:	3.00 Hz	3.00
------------------	---------	-------------

This is used in 'Slip Compensation' control. If you set this value incorrectly, motor may stall during slip compensation control. (See motor nameplate)

FU2▶ Rated-Curr 33	3.6 A	33	3.6
-----------------------	-------	-----------	------------

Factory Default:	3.6 A	3.6
(This value is set according to the motor capacity set in FU2-30)		

This is very importance parameter that must be set correctly. This value is referenced in many other inverter parameters. (See motor nameplate)

FU2▶ NoLoad-Curr 34	1.8 A	34	1.8
------------------------	-------	-----------	------------

Factory Default:	1.8 A	1.8
(This value is set according to the motor capacity set in FU2-30)		

This parameter is only displayed when 'Slip Compen' is selected in FU2-40 [Control Method].

This function is used to maintain constant motor speed. To keep the motor speed constant, the output frequency varies within the limit of slip frequency set in FU2-32 according to the load current. For example, when the motor speed decreases below the reference speed (frequency) due to a heavy load, the inverter increases the

output frequency higher than the reference frequency to increase the motor speed. The inverter increases or decreases the output by delta frequency shown below.

$$\text{Delta Freq.} = \frac{\text{Output current} - \text{No load current}}{\text{Rated current} - \text{No load current}} \times \text{Rated Slip}$$

Output frequency = Reference freq. + Delta freq.

FU2▶ Efficiency 36	72 %	36	72
-----------------------	------	-----------	-----------

Factory Default:	72 %	72
(This value is set according to the motor capacity set in FU2-30)		

This value is used for calculating the output wattage when FU2-72 is set to 'Watt'.

FU2▶ Inertia rate 37	0	37	0
-------------------------	---	-----------	----------

Factory Default:	0	0
------------------	---	----------

This parameter is used for sensorless control, minimum Accel/Decel, optimum Accel/Decel and speed search. For better control performance, this value must be set as exact as possible.

Set '0' for loads that has load inertia less than 10 times that of motor inertia.

Set '1' for loads that have load inertia about 10 times that of motor inertia.

FU2-38: Carrier Frequency

FU2▶ Carrier freq 38	5 kHz	38	5
-------------------------	-------	-----------	----------

Factory Default:	5 kHz	5
------------------	-------	----------

Code	LCD Display	Description	Factory setting	Setting range
FU2-38	Carrier freq	Carrier Frequency	5 [kHz]	1 ~ 15 [kHz]

This parameter affects the audible sound of the motor, noise emission from the inverter, inverter temperature, and leakage current. If the ambient temperature where the inverter is installed is high or other equipment may be affected by potential inverter noise, set this value lower. If set above 10kHz, use it by reducing 5%[1kHz] of the rated current. Setting Carrier frequency set below 2.5[kHz] when the FU2-39 [Control mode selection] is set to Vector_SPD, Vector_TRQ could weaken the control performance.

FU2-39: Control mode selection

FU2▶Control mode	39	0
39 V/F		
Factory Default: V/F		0

- Selects the control mode of the inverter

FU2-40 setting	LCD Display	Description
0	V/F	V/F Control
1	Slip compen	Slip compensation
2	Sensorless_S	Sensorless vector control speed operation
3	Sensorless_T	Sensorless vector control torque operation
4	Vector_SPD	Vector control speed operation
5	Vector_TRQ	Vector control torque operation

Note) Setting Vector_SPD, Vector_TRQ is only valid when the inverter is equipped with SUB-B board and EXT-12[F mode] is set to Feed-back. Vector control comprises of Vector_SPD, Vector_TRQ with secorless vector Sensorless_S and Sensorless_T.

● **V/F control:**

This parameter controls the voltage/frequency ratio constant. It is recommended to use the torque boost function when a greater starting torque is required. Related function : FU1-26~28 [Torque boost]

● **Slip compensation :**

This function is used to maintain constant motor speed. To keep the motor speed constant, the output frequency varies within the limit of slip frequency set in FU2-32

according to the load current. For example, when the motor speed decreases below the reference speed (frequency) due to a heavy load, the inverter increases the output frequency higher than the reference frequency to increase the motor speed. The inverter increases or decreases the output by delta frequency shown below.

$$\text{Delta freq} = \text{Rated slip} * (\text{Output current} - \text{Motor No load current}) / \text{rated current} - \text{Motor No load current}$$

$$\text{Output freq} = \text{Reference freq} + \text{Delta freq}$$

☞ : Motor parameters must be set correctly for better performance of control.

FU2-32~36 [Motor related parameters] is automatically determined by FU2-30 [Rated Motor selection]. Most suitable motor capacity corresponding inverter capacity is set as factory setting, but the following setting value can be adjusted if necessary.

Related parameter :FU2-30~37 [Motor related parameters]

Code	LCD Display	Description
FU2-30	Motor select	Select motor capacity
FU2-32	Rated-Slip	Motor rated slip (Hz)
FU2-33	Rated-Curr	Motor rated current (rms)
FU2-34	Noload-Curr	Motor no load current (rms)
FU2-36	Efficiency	Motor efficiency (%)
FU2-37	Inertia rate	Motor inertia rate

- Sensorless_S (Sensorless vector speed control) operation :

Use it when 1) high starting torque needed at low speed 2) load fluctuation is high 3) rapid response needed.

If not using CMC 220V/440V Class motor: Set Yes in FU2-40 [Auto tuning] first.

Vector_SPD (Vector control speed) operation : only valid when Sub-B board is mounted (Speed-detecting Encoder installed to the motor).

Related parameters : FU2-30~37 [Motor related parameters]
 FU2-41~44 [Motor constant]
 FU2-45~46 [P/I gain for Sensorless]
 EXT-25~26 [P/I gain for Vector_SPD],
 EXT-27~28 [Torque limit for Vector_SPD]

Conditions for Sensorless Vector Control

Conditions for sensorless control are as follows. If one of the following conditions is not satisfied, the inverter may malfunction with insufficient torque, irregular rotation, or excessive motor noise. It is recommended to use V/F control.

- Use a motor capacity that is equal to or one horsepower level lower than the inverter capacity.
- Two different motor parameters can be set for one inverter, but use only one motor parameter for sensorless control.
- If the motor in use is not CMC 220V/440V Class motor or using 220V/380V dual use motor, utilize the auto tuning feature in FU2-40 [Auto tuning] before starting.
- Set appropriate values for the electronic thermal function, the overload limit function and the stall prevention. The set values should not exceed 150% of the rated motor current.
- When DRV-04 [Frequency Mode] is set to "V1", "1", or "V1+", eliminate any potential noise influence with the frequency reference.
- Pole number of the motor should be 2 pole, 4 pole, or 6 pole.
- The distance between the inverter and the motor should not exceed 100m (328 ft).

Precautions When Using Sensorless Control

- Forced-cooling should be used for the motor when the average operating speed is under 20Hz and more than 100% load is used constantly.
- The motor may rotate 0.5% faster than the maximum speed if the motor temperature does not reach normal operating temperature.
- The performance can be improved during regeneration for systems with frequent acceleration and deceleration operations by installing the DB (Dynamic Brake) braking unit option.
- Utilize the auto-tuning feature when the motor reaches normal temperature (average temperature where the motor normally operates).
- Output torque may be reduced when an output filter option is used between the inverter and the motor.
- Speed change is more frequent than the V/F control.
- If the speed changes excessively when the FU2-38 [Carrier Frequency Selection] is set to a value more than 10kHz, change the setting to 5~10kHz.

- Over current fault can occur if the FU2-41 [Stator Resistance (Rs)] is set to a value more than twice the auto tuned value
- Max setting range is 300 Hz.

Detail Tuning Method for Sensorless Vector Control

- Adjust the FU2-34 [No Load Motor Current (RMS)] value larger or smaller by 5% units if the current is larger or smaller than that of V/F control with small load.
- Adjust the FU2-32 [Rated Motor Slip] value larger or smaller by 5% units if the speed is faster or slower than that of V/F control with small load.
- Sensorless_T(Sensorless Vector Torque) Operation:
- Vector_TRQ(Vector control torque) Operation: All settings are the same as Vector_SPD except using torque reference for torque control.

FU2-40 ~ 44 [Auto tuning]

FU2▶ Auto tuning 40 --- NO ---	40	0
-----------------------------------	-----------	----------

Factory Default: NO	0
---------------------	----------

FU2▶ Rs * 41 0.171 ohm	41	0.171
---------------------------	-----------	--------------

Factory Default: 0.171 ohm	0.171
----------------------------	--------------

FU2▶ Lsigma * 42 3.34 mH	42	3.34
-----------------------------	-----------	-------------

Factory Default: 3.34 mH	3.34
--------------------------	-------------

FU2▶ Ls * 43 29.03 mH	43	29.03
--------------------------	-----------	--------------

Factory Default: 29.03 mH	29.03
---------------------------	--------------

FU2▶ Tr * 44 260 ms	44	260
------------------------	-----------	------------

Factory Default: 260 ms	260
-------------------------	------------

Note) * These values are automatically entered according to the FU2-30 [Rated motor selection]. The above values are displayed when FU2-30 is set to 5 (7.5 kW).

- The auto tuning function automatically measures the motor parameters needed for control selected in FU2-39[Control mode selection] such as stator resistance, rotor resistance, leakage inductance, no-load current and Encoder feedback frequency. The motor does not rotate during auto tuning so there is no need to separate the motor from the system.
- Encoder operating status can be checked.
- The rated current, voltage, efficiency and slip described in the motor nameplate should be entered before performing auto tuning. If efficiency is not indicated on the nameplate, use the preset value.
- All or selected parameters can be tuned in Auto-tuning mode.

[Motor rotation mode when set to All, Enc Test, Tr]

1. With PG Option installed: if FU2-40 is set to All, Stator resistance (Rs), Leakage inductance (Lsigma), Stator inductance (Ls), No-load current (Noload-Curr), Speed Encoder status and Rotor constants (Tr) are calculated.
2. Without PG Option installed: if FU2-40 is set to All, Stator resistance (Rs), Leakage inductance (Lsigma), Stator inductance (Ls) and No-load current (Noload-Curr) are calculated.
3. if FU2-40 is set to Rs + Lsigma, Stator resistance (Rs), Leakage inductance (Lsigma) are calculated.
4. Either PG Status or Rotor constant (Tr) can be checked with PG option card installed.

[Motor non-rotation mode when set to Rs + Lsigma]

1. Stator resistance (Rs), Leakage inductance (Lsigma) can be calculated by setting FU2-40 to Rs + Lsigma.
2. User should set Stator resistance (Rs), No-load current (Noload-Curr) and Rotor constants (Tr).
3. To automatically calculate the Stator inductance (Ls), No-load current (Noload-Curr) and Rotor constants (Tr), set the motor rotation mode and FU2-40 to All.

[With PG option card installed]

1. Set EXT-12 to Feed-back.
2. Set EXT-15 to (A + B).
3. if FU2-40 is set to All, Stator resistance (Rs), Leakage inductance (Lsigma), Stator inductance (Ls), No-load current (Noload-Curr), and Rotor constants (Tr) are calculated.
4. Stator resistance (Rs), Leakage inductance (Lsigma) can be calculated by setting FU2-40 to Rs + Lsigma.
5. User should set the Stator inductance (Ls), No-load current (Noload-Curr) and Rotor constants (Tr) if FU2-40 is set to Rs + Lsigma.

[Without PG option card installed]

1. if FU2-40 is set to All, Stator resistance (Rs), Leakage inductance (Lsigma), Stator inductance (Ls), No-load current (Noload-Curr) are calculated.
2. If FU2-40 is set to Rs + Lsigma, Stator resistance (Rs), Leakage inductance (Lsigma) is calculated.
3. User should set the Stator inductance (Ls), No-load current (Noload-Curr).

FU2-40	LCD display	Description
0	No	Auto-tuning disabled
1	All	Auto-tuning all parameters
2	Rs + Lsigma	Stator resistance (Rs) and Leakage inductance (Lsigma) Auto-tuning
3	Enc Test	PG status check
4	Tr	Rotor constant(Tr) calculation

- ➔ Note 1 : Ls and Noload-Curr are only valid during Motor Rotation mode.
- ➔ Note 2 : The motor constants values change with temperature change, so auto tuning is to be conducted after the temperature of the motor is stabilized.
- ➔ Note 3 : The auto-tuning result could be different unless CMC motor is used.
- ➔ Note 4 : The actual motor parameters (Rs, Rr, Lsigma, Tr) can be used or set by user.

Code	LCD display	Name	Description
FU2-34	Noload-Curr	No Load Motor Current (RMS)	Setting and display the No Load Motor Current (RMS)
FU2-40	Auto tuning	Auto Tuning	Auto-tuning enable
FU2-41	Rs	Stator resistance	Setting and display the Stator resistance Rs
FU2-42	Lsigma	Leakage inductance	Setting and display the Lsigma
FU2-43	Ls	Stator inductance	Setting and display the Stator inductance Ls
FU2-44	Tr	Rotor constant	Setting and display the Rotor constant Tr.

[Keypad display during Auto-tuning of motor parameters]

Code	Display		Description
	LED	7-Segment	
FU2-40	Rs Tuning	T1	Displayed during Stator resistance (Rs) Auto-tuning
	Lsigma Tuning	T2	Displayed during Leakage inductance (Lsigma) auto-tuning.
	Ls Tuning	T3	Displayed during Stator inductance (Ls) and No-load current auto-tuning.
	ENC Test	T4	Displayed during Encoder auto-tuning.

Tr Tuning	T5	Displayed during Rotor filter time constant (Tr) auto-tuning
-----------	----	--

[Keypad error display after Encoder test]

Code	Display		Description
	LED	7-Segment	
FU2-40	Enc Err	T6	Displayed when incorrect Encoder wiring error occurs
	Enc Rev	T7	Displayed when Encoder wiring is connected reversly.

[Motor parameter display corresponding to inverter capacity]

Class	inverter capacity	Motor parameter			
		Rs	Lsigma	Ls	Tr
200V	0.8[kW] ~ 5.5[kW]	X.XXX ohm	X.XX mH	X.XX mH	XXX ms
	7.5[kW] ~ 55[kW]	X.X mohm	X.XXX mH	X.XX mH	XXX ms
400V	0.8[kW] ~ 1.5[kW]	X.XX ohm	X.X mH	X. mH	XXX ms
	2.2[kW] ~ 15[kW]	X.XXX ohm	X.XX mH	X.X mH	XXX ms
	18.5[kW] ~ 75[kW]	X.X mohm	X.XXX mH	X.XX	XXX ms

➔ Note : For 7-segment Keypad, parameter unit is not displayed.

Related Functions: FU2-30~37 [Motor related parameters]
 FU2-39 [Control mode selection]
 EXT-01 [Sub Board Type Display]
 EXT-14 [Encoder Feedback Frequency]
 EXT-15 [Pulse Input Signal Selection]

FU2-45: P Gain for Sensorless Control
FU2-46: I Gain for Sensorless Control

FU2▶ SL P-gain	45	3276
45	32767	
Factory Default:	32767	3276

SL P-gain is the proportional gain of speed controller. If this value is set high, you can get fast speed response characteristic. However, if this value is set too high, the steady state characteristics may become unstable.

FU2▶ SL I-gain 46 3276	46	3276
--	-----------	-------------

Factory Default: 3276	3276
----------------------------	-------------

SL I-gain is the integral gain of speed controller. If this value is set low, you can get better transient response characteristic and steady state characteristic. However, if this value is set too low, there may be an overshoot in speed control.

☞ **Note:** The response time of a system is affected by the load inertia. For better control performance, set the FU2-37 [Load Inertia] correctly.

Related Functions: FU2-30 ~ FU2-37 [Motor Parameters]
FU2-40 [Control Method]

FU2-47: PID Operation Selection

FU2▶ Proc PI mode 47 --- NO ---	47	0
---------------------------------------	-----------	----------

Factory Default: No	0
--------------------------	----------

This code selects the PID control. For HVAC or Pump applications, the PID control can be used to adjust the actual output by comparing a feedback with a 'Set-point' given to the inverter. This 'Set-point' can be in the form of Speed, Temperature, Pressure, Flow level, etc. The 'Set-point' and the feedback signals are provided externally to the inverter analog input terminals V1, V2 or I. The inverter compares the signals in calculating 'total-error' which is reflected in the inverter output. Please see FU2-50 to FU2-54 for more detail.

☞ **Note:** PID control can be bypassed to manual operation temporarily by defining one of the multifunction input terminals (P1~P3) to "Open-loop". The inverter will change to manual operation from PID control when this terminal is ON, and change back to PID control when this terminal is OFF.

Related Functions: DRV-04 [Frequency Mode]
I/O-01 to I/O-10 [Analog Signal Setting]
I/O-12 to I/O-14 [Multi-Function Input]
EXT-15 to EXT-21 [Pulse Input Setting]
FU2-50 to FU2-54 [PID Feedback]

FU2-48: PID Reference Frequency Selection FU2-49: PID Reference Mode Selection FU2-50: PID Output Direction Selection

FU2▶ PID Ref 48 Ramp freq.	48	0
-------------------------------	-----------	----------

Factory Default: No	0
--------------------------	----------

This code selects reference frequency for PID control.

[Ramp Freq]: PID control references frequency with Accel and Decel pattern and time.

[Target Freq]: PID control references frequency without Accel and Decel pattern and time.

FU2▶ PID Ref Mode 49 Freq mode	49	0
-----------------------------------	-----------	----------

Factory Default: Freq mode	0
---------------------------------	----------

This code selects reference input for PID control.

[Freq Mode]: PID control references signal set in DRV-04. When selected other than 'Freq mode', PID control references the selected signal regardless the selection in DRV-04.

FU2▶ PID Out Dir 50 Ramp Freq.	50	0
-----------------------------------	-----------	----------

Factory Default: Ramp Freq.	0
----------------------------------	----------

This code selects the direction of output value of PID controller. The output value is added to reference frequency.

FU2-51: PID Feedback Signal Selection
FU2-52: P Gain for PID Control
FU2-53: I Gain for PID Control
FU2-54: D Gain for PID Control
FU2-55: High Limit Frequency for PID Control
FU2-56: Low Limit Frequency for PID Control

FU2▶ PID F/B 51 I	51	0
----------------------	-----------	----------

Factory Default: I		0
--------------------	--	----------

Select the feedback signal for PID control. This can be set one of 'I', 'V1', 'V2' according to the signal (current or voltage) and the terminal (V1 or V2).

FU2▶ PID P-gain 52 300.0 %	52	300.0
-------------------------------	-----------	--------------

Factory Default: 300.0 %		300.0
--------------------------	--	--------------

Set the proportional gain for PID control. When P-Gain is set at 100% and I-Gain at 0.0 second, it means the PID controller output is 100% for 100% error value.

FU2▶ PID I-time 53 30.0 sec	53	30.0
--------------------------------	-----------	-------------

Factory Default: 30.0 sec		30.0
---------------------------	--	-------------

Set the integral gain for PID control. This is the time the PID controller takes to output 100% for 100% error value.

FU2▶ PID D-time 54 0.0 ms	54	0.0
------------------------------	-----------	------------

Factory Default: 0.0 ms		0.0
-------------------------	--	------------

Set the differential gain for PID control.

FU2▶ PID +limit 55 60.00 Hz	55	60.00
--------------------------------	-----------	--------------

Factory Default: 60.00 Hz		60.00
---------------------------	--	--------------

This is the frequency at which the output frequency is limited under during PID control.

FU2▶ PID -limit 56 60.00 Hz	56	60.00
--------------------------------	-----------	--------------

Factory Default: 60.00 Hz		60.00
---------------------------	--	--------------

This is the frequency at which the output frequency is limited over during PID control.

FU2-57: PID Output Inversion
FU2-58: PID Output Scale
FU2-59: PID P2 Gain
FU2-60: P Gain Scale

FU2▶PID Out Inv. 57 --- No ---	57	0
-----------------------------------	-----------	----------

Factory Default: No		0
---------------------	--	----------

This code is used to invert PID controller output.

FU2▶PID OutScale 58 100.0 %	58	100.0
--------------------------------	-----------	--------------

Factory Default: 100.0 %		100.0
--------------------------	--	--------------

This code sets the scale of PID controller output.

FU2▶ PID P2-gain 59 100.0 %	59	100.0
--------------------------------	-----------	--------------

Factory Default: 100.0 %		100.0
--------------------------	--	--------------

This code sets the second P-Gain for PID control. The second P-Gain is can be selected for PID controller by setting a multi-function input (I/O-12 ~ I/O14 or EXT-02 ~ EXT-04) to 'Open-loop'.

FU2▶P-gain Scale 60 100.0 %	60	100.0
--------------------------------	-----------	--------------

Factory Default: 100.0 %		100.0
--------------------------	--	--------------

This code sets the scale of P-Gain and P2-Gain. (FU2-52, FU2-59)

☞ PID output value can be set to '0' by setting a multi-function input terminal (P1 ~ P6) to 'Open loop' in I/O-12 ~ I/O-14 or EXT-02 ~ EXT-04.

☞ The accumulated value by I-Gain can be set to '0' by setting a multi-function input terminal (P1 ~ P6) to 'iTerm Clear' in I/O-12 ~ I/O-14 or EXT-02 ~ EXT-04.

[P Control] This is to compensate the error of a system proportionally. This is used to make the controller response fast for an error. When P control is used alone, the system is easily affected by an external disturbance during steady state.

[I Control] This is to compensate the error of a system integrally. This is used to compensate the steady state error by accumulating them. Using this control alone makes the system unstable.

[PI control] This control is stable in many systems. If “D control” is added, it becomes the 3rd order system. In some systems this may lead to system instability.

[D Control] Since the D control uses the variation ratio of error, it has the merit of controlling the error before the error is too large. The D control requires a large control quantity at start, but has the tendency of increasing the stability of the system. This control does not affect the steady state error directly, but increases the system gain because it has an attenuation effect on the system. As a result, the differential control component has an effect on decreasing the steady state error. Since the D control operates on the error signal, it cannot be used alone. Always use it with the P control or PI control.

Related Functions: DRV-04 [Frequency Mode] FU2-40 [Control Method] I/O-01 ~ I/O-10 [Analog Signal Scaling] EXT-15 ~ EXT-21 [Pulse Input Signals]
--

Process PID Control

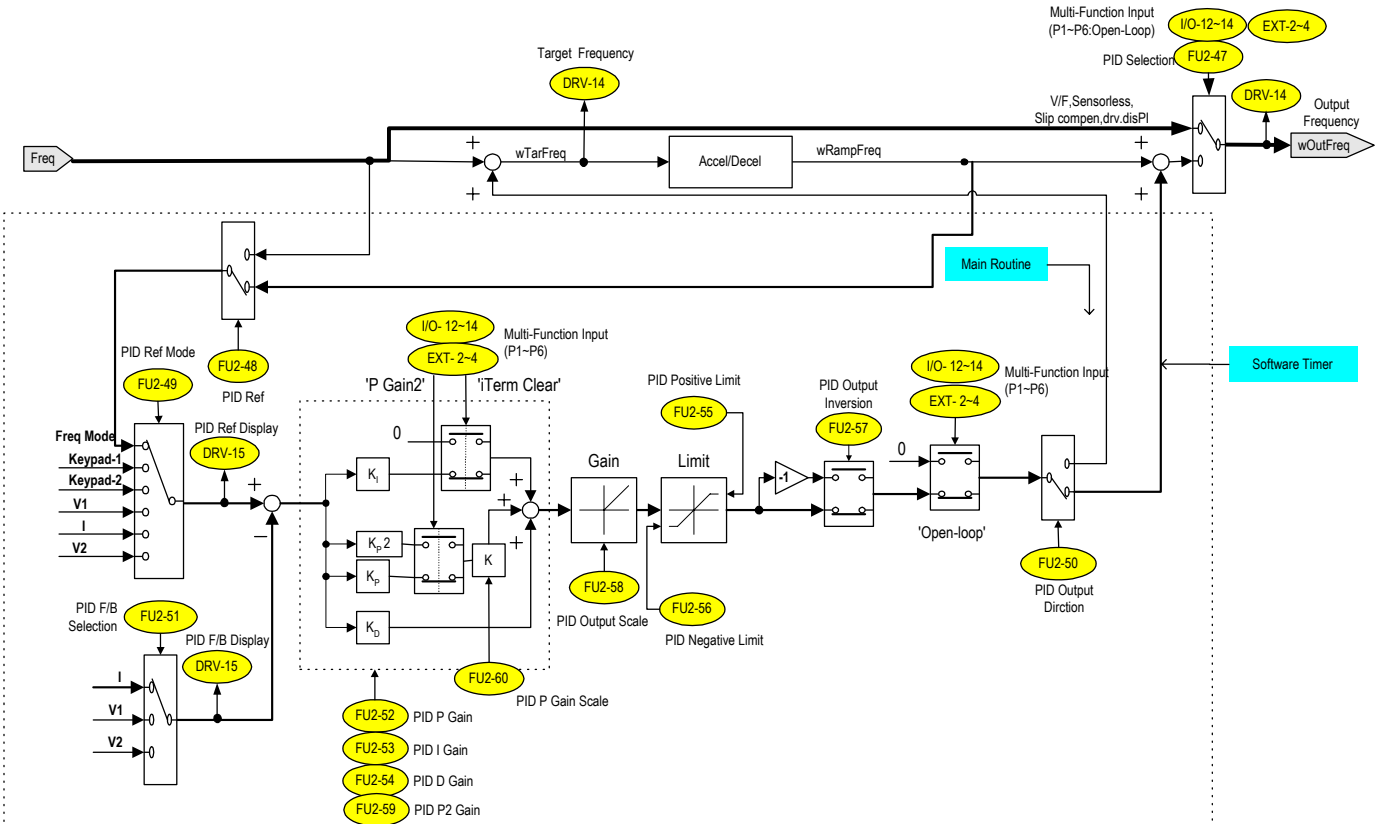

[PID Control Block Diagram]

FU2-69: Accel/Decel Change Frequency

FU2▶Acc/Dec ch F
69 0.00 Hz **69** **0**

Factory Default: 0.00 Hz **0**

This function is used to change Accel/Decel ramp at a certain frequency. This is useful in textile machine application.

Note: If the multi-function input terminal (I/O-12 ~ I/O-14) is set to 'XCEL-L', XCEL-M', or XCEL-H', The Multi-Accel/Decel Time (I/O-25 ~ I/O-38) has the priority.

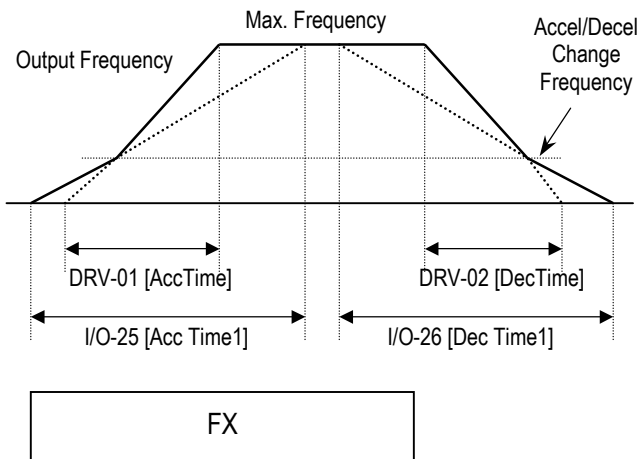

[Accel/Decel Change Operation]

FU2-70: Reference Frequency for Accel/Decel

FU2▶Acc/Dec freq
70 Max freq **70** **0**

Factory Default: Max freq **0**

This is the reference frequency for acceleration and deceleration. If a decided Accel/Decel time from a frequency to a target frequency is required, set this value to 'Delta freq'.

Setting Range		Description
LCD	7-Seg	
Max freq	0	The Accel/Decel time is the time that takes to reach the maximum frequency from 0 Hz.

Delta freq	1	The Accel/Decel time is the time that takes to reach a target frequency from a frequency (currently operating frequency).
------------	---	---

Related Functions: DRV-01, DRV-02 [Accel/Decel Time]
FU2-71 [Accel/Decel Time Scale]
I/O-25 ~ I/O-38 [1st ~ 7th Accel/Decel Time]

FU2-71: Accel/Decel Time Scale

FU2▶ Time scale
71 0.1 sec **71** **0.1**

Factory Default: 0.1 sec **0.1**

This is used to change the time scale.

Related Functions: DRV-01, DRV-02 [Accel/Decel Time]
FU2-70 [Reference Freq. for Accel/Decel]
I/O-25 ~ I/O-38 [1st ~ 7th Accel/Decel Time]

Setting Range		Description
LCD	7-Seg	
0.01 sec	0	The Accel/Decel time is changed by 0.01 second. The maximum setting range is 600 seconds.
0.1 sec	1	The Accel/Decel time is changed by 0.1 second. The maximum setting range is 6000 seconds.
1 sec	2	The Accel/Decel time is changed by 1 second. The maximum setting range is 60000 seconds.

FU2-72: Power On Display

FU2▶PowerOn disp
72 0 **72** **0**

Factory Default: 0 **0**

This code selects the parameter to be displayed first on keypad (DRV-00) when the power is turned on.

Setting Range	Description
0	DRV-00 [Command Frequency]
1	DRV-01 [Acceleration Time]
2	DRV-02 [Deceleration Time]
3	DRV-03 [Drive Mode]

4	DRV-04 [Frequency Mode]
5	DRV-05 [Step Frequency 1]
6	DRV-06 [Step Frequency 2]
7	DRV-07 [Step Frequency 3]
8	DRV-08 [Output Current]
9	DRV-09 [Motor Speed]
10	DRV-10 [DC link Voltage]
11	DRV-11 [User Display selected in FU2-73]
12	DRV-12 [Fault Display]

FU2-73: User display selection

Related parameter : DRV-11 [User display selection]

- Select the display as shown below in FU2-73 [User display selection].

Setting	FU2-73	Name	Description
0	Voltage	Output voltage	Display output voltage of the inverter (Factory setting)
1	Watt	Output power	Display output power of the inverter

Note) The display of "Watt" is approximate value.

FU2-74: Gain for Motor Speed Display

FU2▶ RPM factor	74	100
74 100 %		
Factory Default:	100 %	100

This code is used to change the motor speed display to rotating speed (r/min) or mechanical speed (m/min). The display is calculated by following equation.

Rotating speed = $120 \times F / P$, where F=Output frequency, P= motor pole number

Mechanical speed = Rotating speed x Motor RPM Display Gain

Related Functions:	DRV-00 [Output Frequency] DRV-09 [Motor Speed] FU2-31 [Number of Motor Pole]
---------------------------	--

FU2-75: DB (Dynamic Braking) Resistor Mode Selection

FU2▶ DB mode	75	1
75 Int. DB-R		
Factory Default:	Int. DB-R	1

This code is used to protect the DB resistor from over heating.

Setting Range		Description
LCD	7-Seg	
None	0	This is selected when there is no resistor connected. At this time, inverter does not generate DB turn on signal.
Int. DB-R	1	This is selected when using the internal DB resistor. This must be selected for 1~5 HP inverters because they have internal DB resistor as a default. Enable Duty (%): 2 ~ 3 % Continuous Turn On Time: 5 seconds
Ext. DB-R	2	This is selected when using an external DB resistor. This must be selected for 7.5~10 HP inverters. This must be selected for 1~5 HP inverters in case of using an external DB resistor. Enable Duty (%): 0 ~ 30 % Continuous Turn On Time: 15 seconds

☞ The inverter turns the DB turn on signal OFF when the Continuous Turn On Time expires during dynamic braking, and an over voltage fault can occur. When this happens, increase the deceleration time or install an external high-duty DB resistor.

☞ Install an exterior high-duty DB resistor when the load accelerates and decelerates frequently. Set the FU2-75 [DB Resistor Mode selection] to 'Ext. DB-R', and set the FU2-76 [Duty of DB Resistor].

☞ This does not apply to 15~30 HP inverters. They need the Optional DB unit to use DB resistor.

FU2-76: Duty of DB (Dynamic Braking) Resistor

FU2▶ DB %ED	76	10
76 10 %		
Factory Default:	10 %	10

This must be set when using an external DB resistor. The

duty is calculated by '%ED=Decel time * 100 / (Accel time + Steady speed time + Decel time + Stop status time)'.

FU2-79: Software Version

FU2▶ S/W Version
79 Ver 2.0

79

2.0

Factory Default: Ver. 2.0 **2.0**

Displays the software version.

FU2-81 ~ FU2-90: 2nd Motor Related Functions

These functions are displayed only when one of the multifunction inputs is set at '2nd func' in I/O-12 to I/O-14. When using two motors with an inverter by exchanging them, different values can be set for the 2nd motor by using the multifunction input terminal. Following table is the 2nd functions corresponding to the 1st functions.

2 nd Functions	1 st Functions	Description
FU2-81 [2nd Acc time]	DRV-01 [Acc. time]	Acceleration time
FU2-82 [2nd Dec time]	DRV-02 [Dec. time]	Deceleration time
FU2-83 [2nd BaseFreq]	FU1-21 [Base freq]	Base Frequency
FU2-84 [2nd V/F]	FU1-29 [V/F Pattern]	Volts/Hz mode
FU2-85 [2nd F-boost]	FU1-27 [Fwd Boost]	Forward torque boost
FU2-86 [2nd R-boost]	FU1-28 [Rev Boost]	Reverse torque boost
FU2-87 [2nd Stall]	FU1-60 [Stall Level]	Stall prevention level
FU2-88 [2nd ETH 1min]	FU1-51 [ETH 1min]	ETH level for 1 minute
FU2-88 [2nd ETH cont]	FU1-52 [ETH cont]	ETH level for continuous
FU2-90 [2nd R-Curr]	FU2-33 [Rated-Curr]	Motor rated current

The 1st functions are applied if the multifunction terminal is not defined to '2nd Func' or if it is not ON. The 2nd function parameters are applied when the multifunction input terminal set to '2nd Func' is ON. Parameters not listed on the table above are applied to the 2nd motor as to the 1st motor.

Exchange the motor connection from the 1st motor to the 2nd motor or the opposite when the motor is stopped. Over voltage or over current fault can occur when the motor connection is exchanged during operation.

The 'User V/F' function of FU1-29 [V/F Pattern] is used for both the 1st motor and the 2nd motor.

**FU2-91: Parameter Read
FU2-92: Parameter Write**

FU2▶ Para. read
91 --- No ---

Factory Default: No

FU2▶ Para. write
92 --- No ---

Factory Default: No

This is useful for programming multiple inverters to have same parameter settings. The LCD keypad can read (upload) the parameter settings from the inverter memory and can write (download) them to other inverters. This function is only available with LCD keypad.

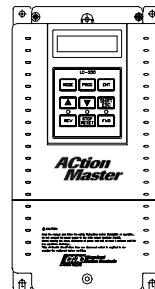

FU2▶ Para. read
91 --- Yes ---

Parameter Upload

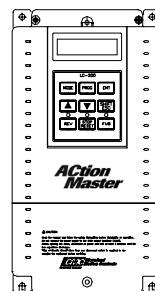
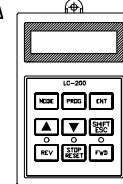

FU2▶ Para. write
92 --- Yes ---

Parameter Download

FU2-93: Parameter Initialize

FU2▶ Para. init 93 --- No ---	93	0
----------------------------------	-----------	----------

Factory Default: No	0
---------------------	----------

This is used to initialize parameters back to the factory default values. Each parameter group can be initialized separately.

Setting Range		Description
LCD	7-Seg	
No	0	Displayed after initializing parameters.
All Groups	1	All parameter groups are initialized to factory default value.
DRV	2	Only Drive group is initialized.
FU1	3	Only Function 1 group is initialized.
FU2	4	Only Function 2 group is initialized.
I/O	5	Only Input/Output group is initialized.
EXT	6	Only External group is initialized.
COM	7	Only Communication group is initialized.
APP	8	Only Application group is initialized.

☞ **Note:** FU1-30 ~ FU1-37 [Motor Parameters] must be set first after initializing parameters.

FU2-94: Parameter Write Protection

FU2▶ Para. lock 94 0	94	0
-------------------------	-----------	----------

Factory Default: 0	0
--------------------	----------

This function is used to lock the parameters from being changed. When the parameters are locked, the display arrow changes from solid to dashed line. The lock and unlock code is '12'.

FU2-99: Return Code (7-Segment Keypad)

99	0
-----------	----------

Factory Default:	0
------------------	----------

This code is used to exit a group when using a 7-segment keypad. After pressing **PROG/ENT** key, set the value to '1' and press the **PROG/ENT** key again to exit.

Related Functions:	FU1-99 [Return Code] I/O-99 [Return Code] EXT-99 [Return Code] COM-99 [Return Code]
---------------------------	--

Notes:

6.4 Input/Output Group [I/O]

I/O-00: Jump to Desired Code

I/O▶ Jump code
00 1

Factory Default: 1

Jumping directly to any parameter code can be accomplished by entering the desired code number. This code is available only with LCD keypad.

I/O-01 ~ I/O-05: Analog Voltage Input (V1) Signal Adjustment

This is used to adjust the analog voltage input signal when the frequency is referenced by the control terminal 'V1'. This function is applied when DRV-04 is set to 'V1' or 'V1+'. Reference frequency versus Analog voltage input curve can be made by four parameters of I/O-02 ~ I/O-04.

I/O▶ V1 filter 01 10 ms **01** **10**

Factory Default: 10 ms **10**

This is the filtering time constant for V1 signal input. Increase this value if the V1 signal is affected by noise causing unstable operation of the inverter. Increasing this value makes response time slower.

I/O▶ V1 volt x1 02 0.00 V **02** **0.00**

Factory Default: 0.00 V **0.00**

This is the minimum voltage of the V1 input at which inverter outputs minimum frequency.

I/O▶ V1 volt y1 03 0.00 Hz **03** **0.00**

Factory Default: 0.00 Hz **0.00**

This is the inverter output minimum frequency when there is the minimum voltage (I/O-02) on the V1 terminal.

I/O▶ V1 volt x2 04 0.00 V **04** **10.00**

Factory Default: 10.00 V **10.00**

This is the maximum voltage of the V1 input at which inverter outputs maximum frequency.

I/O▶ V1 volt y2 05 60.00 Hz **05** **60.00**

Factory Default: 60.00 Hz **60.00**

This is the inverter output maximum frequency when there is the maximum voltage (I/O-03) on the V1 terminal.

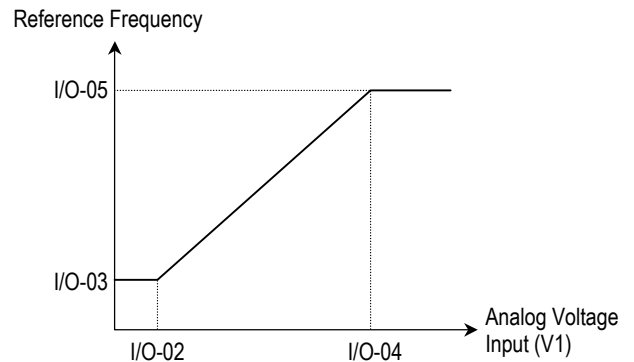

[Reference Frequency vs. Analog Voltage Input, V1 (0 to 10V)]

Related Functions: DRV-04 [Frequency Mode]
FU1-20 [Maximum Frequency]

I/O-06 ~ I/O-10: Analog Current Input (I) Signal Adjustment

This is used to adjust the analog current input signal when the terminal 'I' references the frequency. This function is applied when DRV-04 is set to 'V1' or 'V1+'. Reference frequency versus Analog current input curve can be made by four parameters of I/O-07 ~ I/O-10.

I/O▶ I filter 06 10 ms **06** **10**

Factory Default: 10 ms **10**

This is the filtering time constant for 'I' signal input. If the 'I' signal is affected by noise causing unstable operation of the inverter, increase this value. Increasing this value makes response time slower.

I/O▶ I curr x1 07 4.00 mA	07	4.00
Factory Default: 4.00 mA		4.00

This is the minimum current of the 'I' input at which inverter outputs minimum frequency.

I/O▶ I freq y1 08 0.00 Hz	08	0.00
Factory Default: 0.00 Hz		0.00

This is the inverter output minimum frequency when there is minimum current (I/O-07) on the 'I' terminal.

I/O▶ I curr x2 09 20.00 mA	09	20.00
Factory Default: 20.00 mA		20.00

This is the maximum current of the 'I' input at which inverter outputs maximum frequency.

I/O▶ I freq y2 10 60.00 Hz	10	60.00
Factory Default: 60.00 Hz		60.00

This is the inverter output maximum frequency when there is the maximum current (I/O-09) on the 'I' terminal.

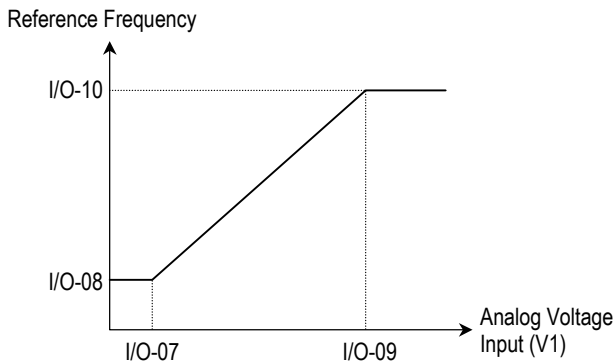

[Reference Frequency vs. Analog Current Input, I (4 to 20mA)]

Related Functions: DRV-04 [Frequency Mode]
FU1-20 [Maximum Frequency]

I/O-11: Criteria for Analog Input Signal Loss

I/O▶ Wire broken 11 None	11	0
Factory Default: None		0

This is to set the criteria for analog input signal loss when DRV-04 [Frequency Mode] is set to 'V1', 'I' or 'V1+I'. Following table shows the setting value.

Setting Range		Description
LCD	7-Seg	
None	0	Does not check the analog input signal.
half of x1	1	The inverter determines that the frequency reference is lost when the analog input signal is less than half of the minimum value (I/O-02 or I/O-07).
below x1	2	The inverter determines that the frequency reference is lost when the analog input signal is less than the minimum value (I/O-02 or I/O-07).

When the analog input signal is lost, inverter displays the following table.

Setting Range		Description
LCD	7-Seg	
LOP	LP	Loss of frequency reference from Option Board (DPRAM time out)
LOR	LR	Loss of frequency reference from Option Board (Communication fault)
LOV	LV	Loss of analog input signal, V1
LOI	LI	Loss of analog input signal, I
LOX	LX	Loss of frequency reference from Sub-Board, V2 or ENC

Related Functions: I/O-48 [Lost command] selects the operation after determining the loss of frequency reference.

The following table shows the selection in I/O-48.

Setting Range		Description
LCD	7-Seg	
None	0	Continuous operating after loss of frequency reference.
FreeRun	1	Inverter cuts off its output after determining loss of frequency reference.
Stop	2	Inverter stops by its Decel pattern and Decel time after determining loss of frequency reference.

I/O-49 [Time out] sets the waiting time before determining the loss of reference signal. Inverter waits to determine the loss of a reference signal until times out.

Note: I/O-48 and I/O-49 also apply when DRV-04 is set to 'Keypad-1' or 'Keypad-2' for determining the loss of command frequency.

Related Functions:	DRV-04 [Frequency Mode] I/O-02 [V1 Input Minimum Voltage] I/O-07 [I Input Minimum Current] I/O-48 [Lost command] I/O-49 [Time out]
---------------------------	--

I/O-12: Multi-function Input Terminal 'P1' Define
I/O-13: Multi-function Input Terminal 'P2' Define
I/O-14: Multi-function Input Terminal 'P3' Define

I/O▶ P1 dedine 12 Speed-L	12	0
------------------------------	-----------	----------

Factory Default: Speed-L	0
--------------------------	----------

I/O▶ P2 dedine 13 Speed-M	13	1
------------------------------	-----------	----------

Factory Default: Speed-M	1
--------------------------	----------

I/O▶ P3 dedine 14 Speed-H	14	2
------------------------------	-----------	----------

Factory Default: Speed-H	2
--------------------------	----------

Multi-function input terminals can be defined for many different applications. The following table shows the various definitions for them.

Setting Range		Description
LCD	7-Seg	
Speed-L	0	Multi-step speed - Low
Speed-M	1	Multi-step speed - Mid
Speed-H	2	Multi-step speed - High
XCEL-L	3	Multi-accel/decel - Low
XCEL-M	4	Multi-accel/decel - Mid
XCEL-H	5	Multi-accel/decel - High
Dc-brake	6	DC injection braking during stop
2nd Func	7	Exchange to 2 nd functions
Exchange	8	Exchange to commercial power line
-Reserved-	9	Reserved for future use
Up	10	Up drive
Down	11	Down drive
3-Wire	12	3 wire operation
Ext Trip-A	13	External trip A
Ext Trip-B	14	External trip B
iTerm Clear	15	Used for PID control
Open-loop	16	Exchange between PID mode and V/F mode
Main-drive	17	Exchange between Option and Inverter
Analog hold	18	Hold the analog input signal
XCEL stop	19	Disable accel and decel
P Gain2	20	Used for PID control
SEQ-L	21	Sequence operation - Low
SEQ-M	22	Sequence operation - Mid
SEQ-H	23	Sequence operation - High
Manual	24	Exchange between Sequence operation and Manual operation
Go step	25	Triggering Sequence operation (Auto-B)
Hold step	26	Hold last step (Auto-A)
Trv Off.Lo	27	Used for Traverse Operation
Trv Off.Hi	28	
Interlock1	29	Used for MMC operation
Interlock2	30	
Interlock3	31	
Interlock4	32	

[Speed-L, Speed-M, Speed-H]

By setting P1, P2, P3 terminals to 'Speed-L', 'Speed-M' and 'Speed-H' respectively, inverter can operate at the preset frequency set in DRV-05 ~ DRV-07 and I/O-20 ~ I/O-24.

The step frequencies are determined by the combination of P1, P2 and P3 terminals as shown in the following table.

Step Frequency	Parameter Code	Speed-H (P3)	Speed-M (P2)	Speed-L (P1)
Step Freq-0	DRV-00	0	0	0
Step Freq-1	DRV-05	0	0	1
Step Freq-2	DRV-06	0	1	0
Step Freq-3	DRV-07	0	1	1
Step Freq-4	I/O-21	1	0	0
Step Freq-5	I/O-22	1	0	1
Step Freq-6	I/O-23	1	1	0
Step Freq-7	I/O-24	1	1	1

0: OFF, 1: ON

☞ I/O-20 [Jog Frequency] can be used as one of the step frequencies.

☞ If the 'Jog' terminal is ON, inverter operates to Jog frequency regardless of other terminal inputs.

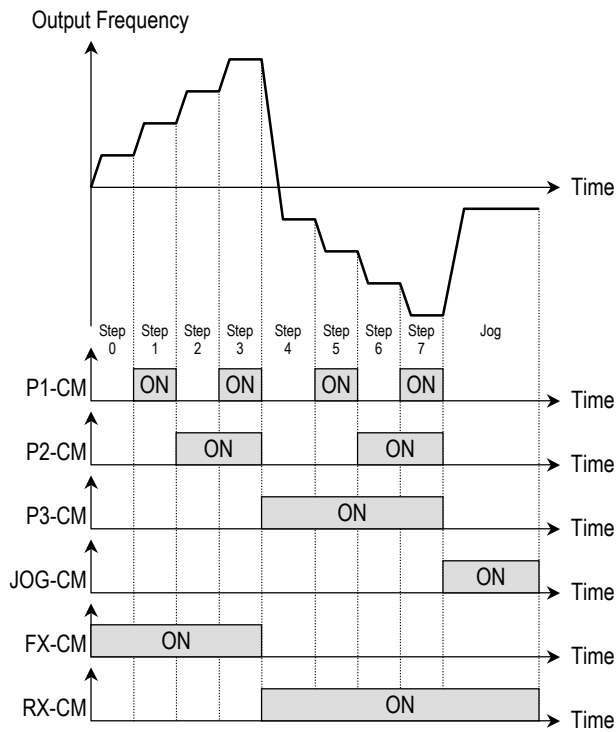

[Multi-Step Frequency Operation]

Related Functions: DRV-05 ~ DRV-07 [Step Frequency]
I/O-20 [Jog Frequency]
I/O-20 ~ I/O-24 [Step Frequency]

☞ **Note:** The frequency for 'Speed 0' is determined by DRV-04.

[XCEL-L, XCEL-M, XCEL-H]

By setting P1, P2 and P3 terminals to 'XCEL-L', 'XCEL-M'

and 'XCEL-H' respectively, up to 8 different Accel and Decel times can be used. The Accel/Decel time is set in DRV-01 ~ DRV-02 and I/O-25 ~ I/O-38.

The Accel/Decel time is determined by the combination of P1, P2 and P3 terminals as shown in the following table.

Accel/Decel Time	Parameter Code	XCEL-H (P3)	XCEL-M (P2)	XCEL-L (P1)
Accel Time-0	DRV-01	0	0	0
Decel Time-0	DRV-02			
Accel Time-1	I/O-25	0	0	1
Decel Time-1	I/O-26			
Accel Time-2	I/O-27	0	1	0
Decel Time-2	I/O-28			
Accel Time-3	I/O-29	0	1	1
Decel Time-3	I/O-30			
Accel Time-4	I/O-31	1	0	0
Decel Time-4	I/O-32			
Accel Time-5	I/O-34	1	0	1
Decel Time-5	I/O-35			
Accel Time-6	I/O-36	1	1	0
Decel Time-6	I/O-37			
Accel Time-7	I/O-38	1	1	1
Decel Time-7	I/O-39			

0: OFF, 1: ON

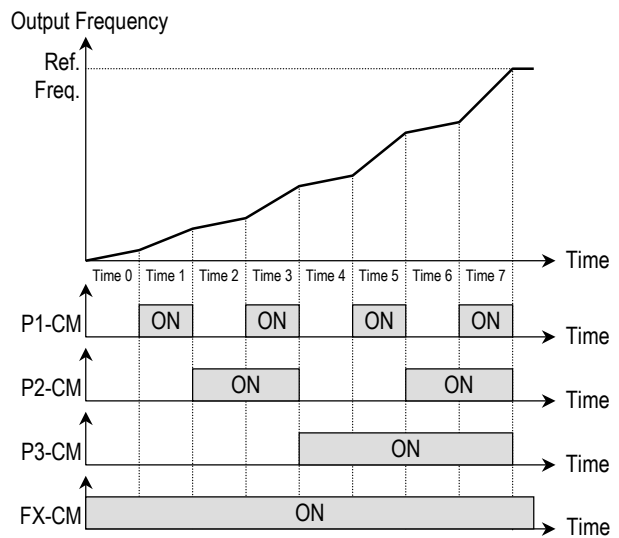

[Multi-Accel/Decel Time Operation]

Related Functions: I/O-25 ~ I/O-38 [1st ~7th Accel/Decel Time]

[Dc-brake]

DC Injection Braking can be activated during inverter stopped by configuring one of the multi-function input terminals (P1, P2, P3) to 'Dc-brake'. To activate the DC Injection Braking, close the contact on the assigned terminal while the inverter is stopped.

[Exchange]

Exchange is used to bypass the motor from the inverter line to commercial power or the opposite. To bypass the motor to commercial line, set the 'Exchange' function in multi-function output terminal and 'INV line', 'COMM line' function in multi-function output terminal. Speed search function (FU2-22) is activated automatically during exchanging operation.

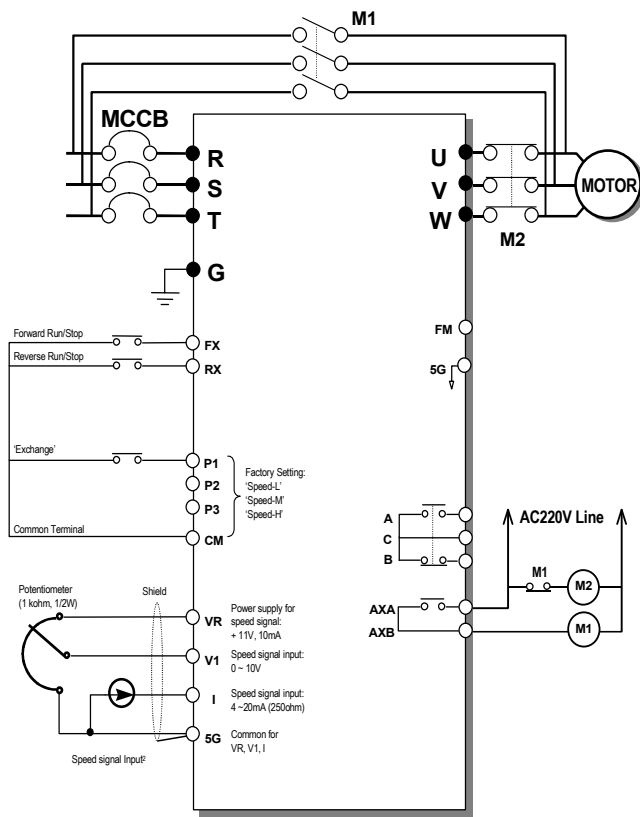

[Wiring to By-Pass Motor to Commercial line]

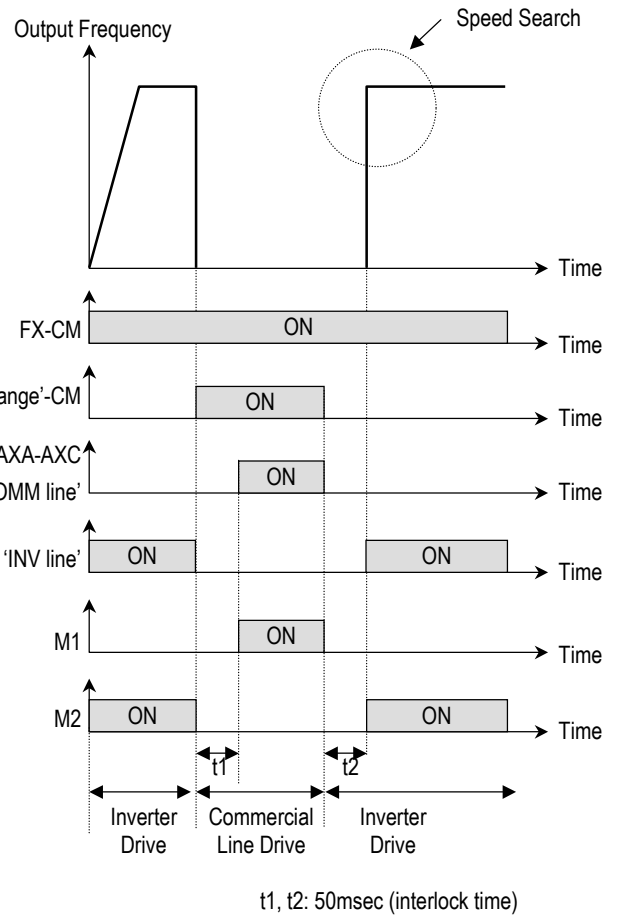

[Exchanging Sequence]

[Up, Down]

By using the Up and Down function, the drive can accelerate to a steady speed and decelerate down to a desired speed by using only two input terminals.

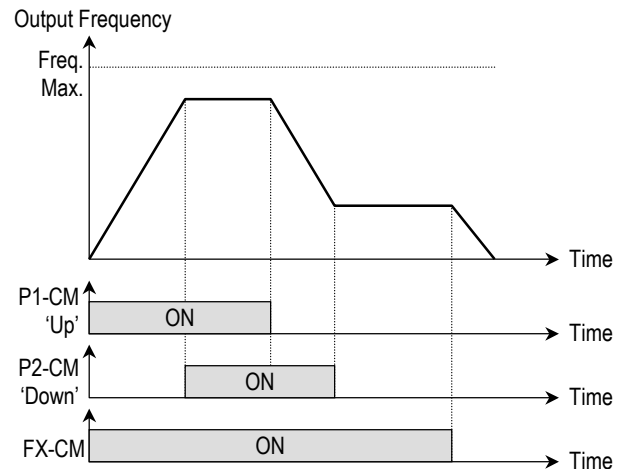

[Up/Down Operation]

[3-Wire]

This function is for 3-wire start/stop control. This function is mainly used with a momentary push button to hold the current frequency output during acceleration or deceleration.

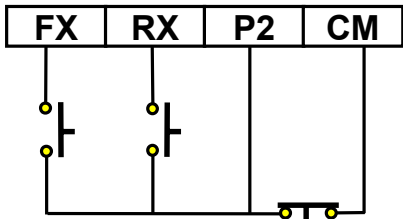

[Wiring for 3-Wire Operation, P2 set to '3-Wire']

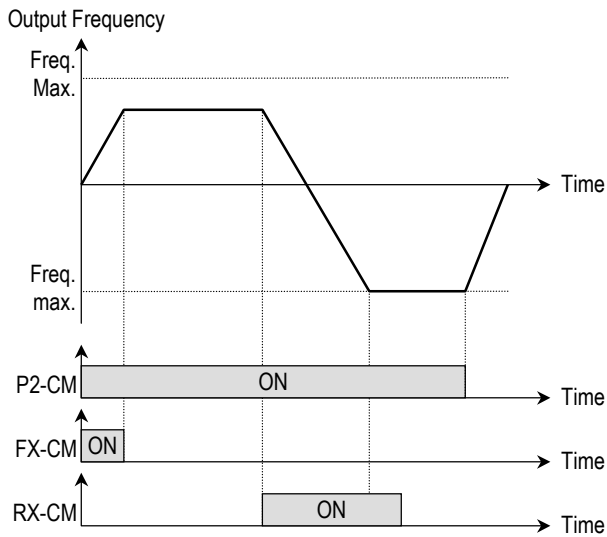

[3-Wire Operation]

[Ext Trip-A]

This is a normally open contact input. When a terminal set to 'Ext Trip-A' is ON, inverter displays the fault and cuts off its output. This can be used as an external latch trip.

[Ext Trip-B]

This is a normally closed contact input. When a terminal set to 'Ext Trip-B' is OFF, inverter displays the fault and cuts off its output. This can be used as an external latch trip.

[iTerm Clear]

This function is used for PID control. When this terminal is ON, the accumulated value by I-Gain is set to '0'. Refer to [PID Control Block Diagram](#).

[Open-loop]

This is used to exchange the control mode of inverter from PID mode (Close Loop) to V/F mode (Open Loop). DRV-03 [Drive Mode] and DRV-04 [Frequency Mode] are applied when the mode has been changed.

Note: This function can be used only when the inverter is stopped.

[Main-drive]

When an option board (like RS485, DeviceNet, F-Net) is installed and used for the frequency setting and the run/stop command, the inverter operation can be changed to manual operation using this function without changing parameters.

FU1-02 [Frequency Mode] and FU1-01 [Drive Mode] are applied when the mode has been changed.

Note: this function can be used only when the inverter is stopped.

[Analog hold]

When there is an analog input signal for frequency reference and 'Analog hold' terminal is ON, inverter fixes its output frequency regardless of the frequency reference change. The changed frequency reference is applied when the terminal is OFF.

This function is useful when a system requires constant speed after acceleration.

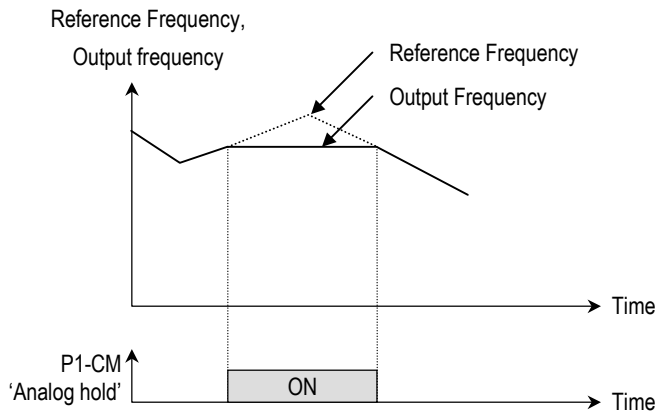

[Analog hold Operation]

[XCEL stop]

Inverter stops accelerating and decelerating when this terminal is ON.

[P Gain2]

This function is used to change P-Gain during PID operation. When this terminal is ON, PID controller changes P-Gain with PID P2-Gain set in FU2-59. Refer to PID Control Block Diagram.

[SEQ-L, SEQ-M, SEQ-H]

These functions are used for Auto drive (I/O-50). Five different sequences can be selected according to the combination of these terminals. Eight step frequencies, Accel/Decel time and steady speed time can be set for each sequence. The following table shows the sequence of selection.

Step Frequency	Parameter Code	Speed-H (P3)	Speed-M (P2)	Speed-L (P1)
Sequence 1	I/O-50 ~ I/O-84	0	0	1
Sequence 2		0	1	0
Sequence 3		1	0	0
Sequence 4		0	1	1
Sequence 5		1	0	1

0: OFF, 1: ON

Note: The inverter stops after finishing all steps of that sequence once the Auto (Sequence) operation is started. To stop the inverter during sequence operation, use 'BX' terminal on the control terminal strip.

Related Functions: I/O-51 ~ I/O-84 [Sequence Operation]

[Manual]

This is used to exchange the operation mode of inverter from Auto (Sequence) to manual operation. DRV-03 [Drive Mode] and DRV-04 [Frequency Mode] are applied when the mode has been changed.

Note: This function can be used only when the inverter is stopped.

[Go step]

This is used to trigger the next step in a sequence of Auto-B operation.

Related Functions: I/O-51 ~ I/O-84 [Sequence Operation]

[Hold step]

This is used to hold the last step frequency in Auto-A operation.

Related Functions: I/O-51 ~ I/O-84 [Sequence Operation]

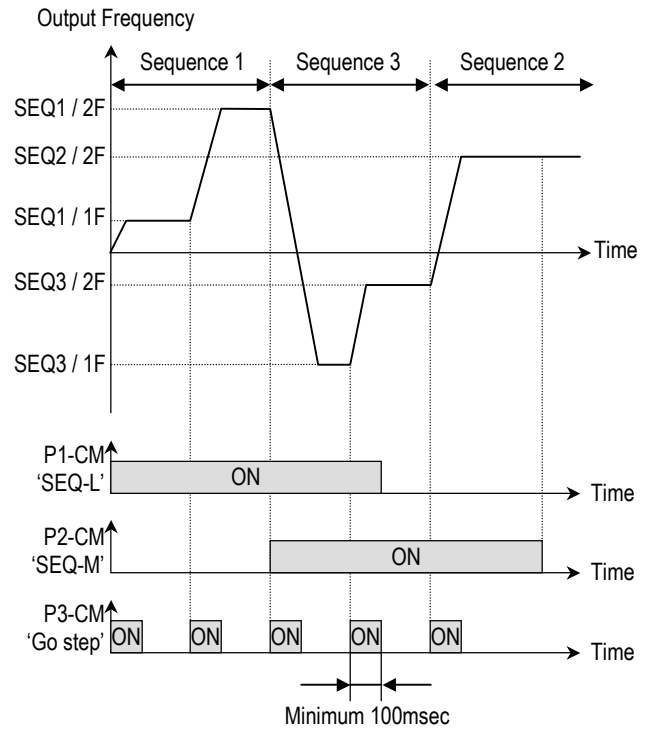

['Go step' in Auto-B Operation]

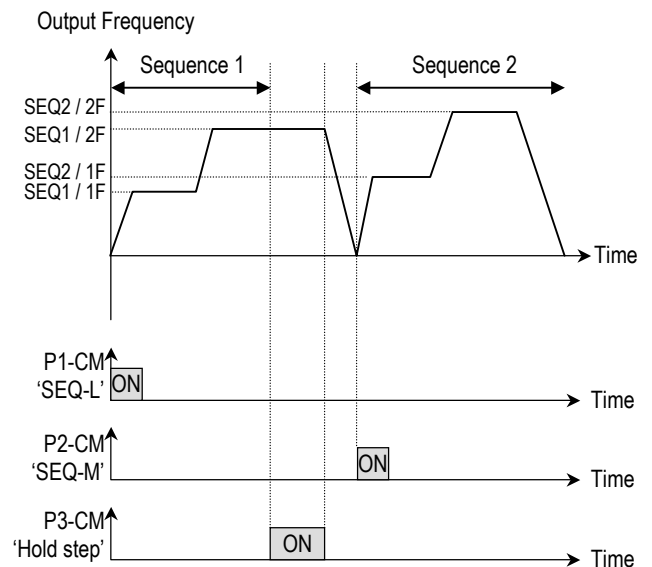

['Hold step' in Auto-A Operation]

[Trv Off.Lo]

This function is used to make negative offset during traverse operation.

Related Functions: APP-06 ~ APP-07 [Traverse Offset]

[Trv Off.Hi]

This function is used to make positive offset during traverse operation.

Related Functions: APP-06 ~ APP-07 [Traverse Offset]

[Interlock1, 2, 3, 4]

This function is used for MMC operation. Refer to MMC operation.

Related Functions: APP-29 [Inter-Lock Selection]

**I/O-15: Terminal Input Status
I/O-16: Terminal Output Status**

I/O▶ In status	15	0000
15	000000000	

Factory Default: 000000000

This code displays the input status of control terminals. Terminals P4, P5, P6 and Q1, Q2, Q3 are provided on optional Sub-Board.

[LCD Keypad Display]

Input	JOG	FX	RX	P6	P5	P4	P3	P2	P1
Terminals	Bit 8	Bit 7	Bit 6	Bit 5	Bit 4	Bit 3	Bit 2	Bit 1	Bit 0
OFF status	0	0	0	0	0	0	0	0	0
ON status	1	1	1	1	1	1	1	1	1

[7-Segment Keypad Display]

The 'JOG' terminal is not displayed on 7-Segment keypad.

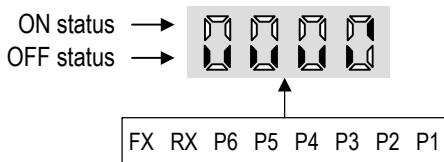

I/O▶ Out status	16	0000
16	0000	

Factory Default: 0000

This code displays the output status of control terminals.

[LCD Keypad Display]

Output	AXA-AXC	Q3	Q2	Q1
Terminals	Bit 3	Bit 2	Bit 1	Bit 0
OFF status	0	0	0	0
ON status	1	1	1	1

[7-Segment Keypad Display]

The 'JOG' terminal is not displayed on 7-Segment keypad.

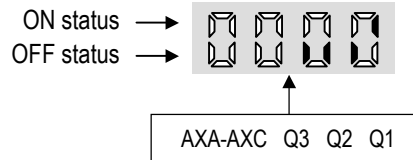

I/O-17: Filtering Time Constant for Multi-function Input Terminals

I/O▶Ti Filt Num	17	15
17	15	

Factory Default: 15

This is the response time constant for terminal inputs (JOG, FX, RX, P3, P2, P1, RST, BX). This is useful where there is a potential for noise. The response time is determined by 'Filtering time constant * 0.5msec'.

I/O-20: Jog Frequency

I/O▶ Jog freq	20	10.00
20	10.00 Hz	

Factory Default: 10.00 Hz

This code sets the jog frequency. See [Speed-L, Speed-M, Speed-H] in I/O-12 ~ I/O-14.

I/O-21 ~ I/O-24: Step Frequency 4, 5, 6, 7

I/O▶ Step freq-4 21 40.00 Hz	21	40.00
--------------------------------------	-----------	--------------

Factory Default: 40.00 Hz **40.00**

-
-
-

I/O▶ Step freq-7 24 30.00 Hz	24	30.00
--------------------------------------	-----------	--------------

Factory Default: 30.00 Hz **30.00**

These codes set the step frequencies. These frequencies are applied when the multi-function input terminals (P1, P2, P3) select the step. See [Speed-L, Speed-M, Speed-H] in I/O-12 ~ I/O-14.

Related Functions: DRV-05 ~ DRV-07 [Step Frequency 1 ~ 3]
 I/O-12 ~ I/O-14 [Multi-function inputs]
 I/O-17 [Filtering Time Constant]

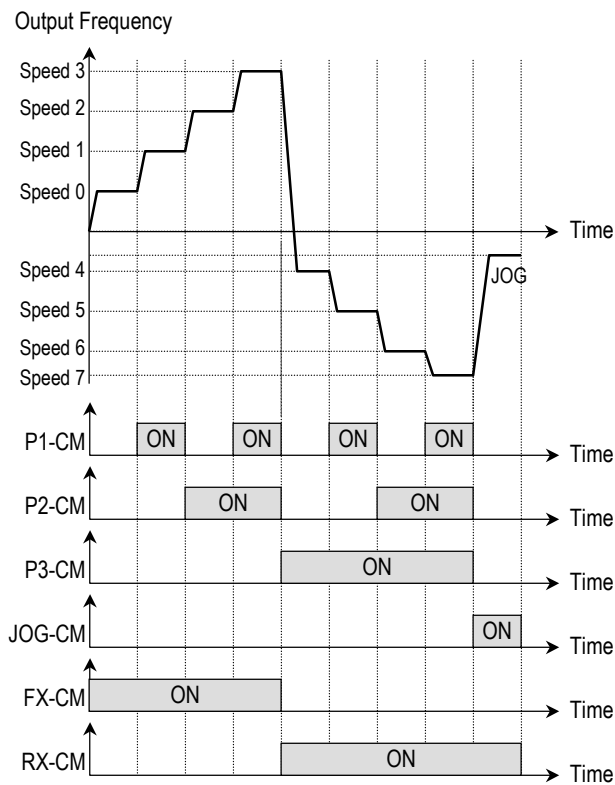

[‘JOG’ and ‘Multi-Step’ Operation]

I/O-25 ~ I/O-38: 1st ~ 7th Accel/Decel Time

I/O▶ Acc time-1 25 20.0 sec	25	20.00
-------------------------------------	-----------	--------------

Factory Default: 20.0 sec **20.0**

-
-
-

I/O▶ Dec time-7 38 20.0 sec	38	20
-------------------------------------	-----------	-----------

Factory Default: 20.0 sec **20.0**

These codes are applied when the multi-function input terminals (P1, P2, P3) select the Accel/Decel time. See [XCEL-L, XCEL-M, XCEL-H] in I/O-12 ~ I/O-14.

Related Functions: DRV-01 ~ DRV-02 [Accel/Decel Time]
 FU2-70 [Reference Freq. for Accel/Decel]
 FU2-71 [Accel/Decel Time Scale]
 I/O-12 ~ I/O-14 [Multi-function inputs]

**I/O-40: FM (Frequency Meter) Output
I/O-41: FM Adjustment**

I/O▶ FM mode 40 Frequency	40	0
-----------------------------------	-----------	----------

Factory Default: Frequency **0**

I/O▶ FM Adjust 41 100 %	41	100
---------------------------------	-----------	------------

Factory Default: 100 % **100**

Frequency meter displays the inverter output Frequency, Current, Voltage and DC link voltage with pulse signals on the FM terminal. The average ranges from 0V to 10V. I/O-41 is used to adjust the FM value.

[Frequency]

FM terminal outputs inverter output frequency. The output value is determined by,
FM Output Voltage = (Output freq. / Max. freq.) × 10V × IO-41 / 100

[Current]

FM terminal outputs inverter output current. The output value is determined by,
 FM Output Voltage = (Output current / Rated current) × 10V × IO-41 / 150

[Voltage]

FM terminal outputs inverter output voltage. The output value is determined by,
 FM Output Voltage = (Output voltage / Max. output voltage) × 10V × IO-41 / 100

[DC link vtg]

FM terminal outputs the DC link voltage of inverter. The output value is determined by,
 FM Output Voltage = (DC link voltage / Max. DC link voltage) × 10V × IO-41 / 100

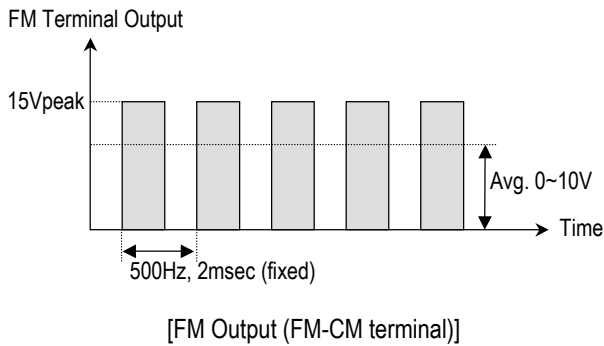

[Torque]

FM terminal outputs the torque of inverter. The output value is determined by
 FM Output Voltage = (Torque current / Max.Torque current) × 10V × IO-41 / 150

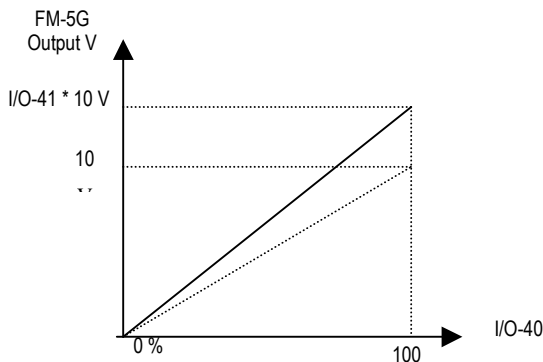

Note : 1. Max output voltage : 200V class -> 220V

- 400V class -> 440V
- 2. Max DC link voltage : 200V class -> 400V
400V class -> 800V
- 3. Refer to chapter 2 Specification for inverter rated current.

**I/O-42: FDT (Frequency Detection) Level
I/O-43: FDT Bandwidth**

I/O▶ FDT freq 42	30.00 Hz	42	30.00
Factory Default:		30.00 Hz	30.00

I/O▶ FDT band 43	10.00 Hz	43	10.00
Factory Default:		10.00 Hz	10.00

These functions are used in I/O-44 [Multi-function Auxiliary Contact Output]. See [FDT-#] in I/O-44.

Related Functions: I/O-44 [Multi-function Auxiliary Output]

I/O-44: Multi-function Auxiliary Contact Output define (AXA-AXC)

I/O▶ Aux mode 44	Run	44	12
Factory Default:		Run	12

The auxiliary contact works (Close) when the defined condition has occurred.

Setting Range		Description
LCD	7-Seg	
FDT-1	0	Output frequency arrival detection
FDT-2	1	Specific frequency level detection
FDT-3	2	Frequency detection with pulse
FDT-4	3	Frequency detection with contact closure
FDT-5	4	Frequency detection with contact closure (inverted FDT-4)
OL	5	Overload detection
IOL	6	Inverter overload detection
Stall	7	Stall prevention mode detection
OV	8	Over voltage detection
LV	9	Low voltage detection
OH	10	Overheat detection

Setting Range		Description
LCD	7-Seg	
Lost Command	11	Lost command detection
Run	12	Inverter running detection
Stop	13	Inverter stop detection
Steady	14	Steady speed detection
INV line	15	Exchange signal outputs
COMM line	16	
Ssearch	17	Speed search mode detection
Step pulse	18	Step detection in Auto mode
Seq pulse	19	Sequence detection in Auto mode
Ready	20	Inverter ready detection
Trv. ACC	21	Traverse acceleration frequency
Trv. DEC	22	Traverse deceleration frequency
MMC	23	Used for MMC operation
Zspd Dect	24	0 Rpm detection signal during vector control
Torq Dect	25	Torque detection signal during vector and sensorless control.

[FDT-1]

When the output frequency reaches the reference frequency (target frequency), AXA-AXC terminal is CLOSED.

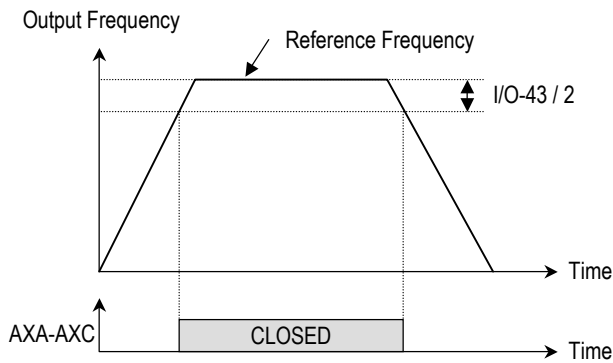

[AXA-AXC configured as 'FDT-1']

[FDT-2]

AXA-AXC is CLOSED when the reference frequency is in I/O-43 [FDT Bandwidth] centered on I/O-42 [FDT Frequency], and the output frequency reaches I/O-43 centered on I/O-42.

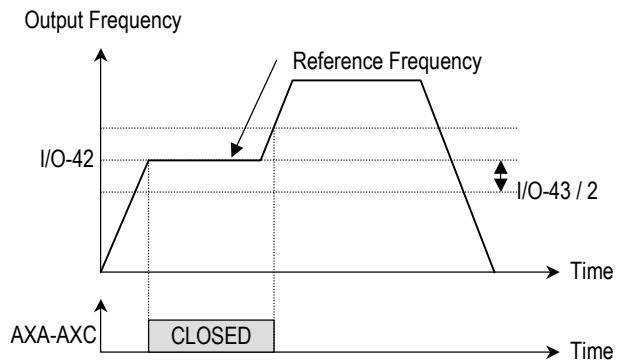

[AXA-AXC configured as 'FDT-2']

[FDT-3]

AXA-AXC is CLOSED when the output frequency reaches the band centered on the FDT frequency. The output is OPENED when the output frequency goes outside the FDT bandwidth centered on the FDT frequency.

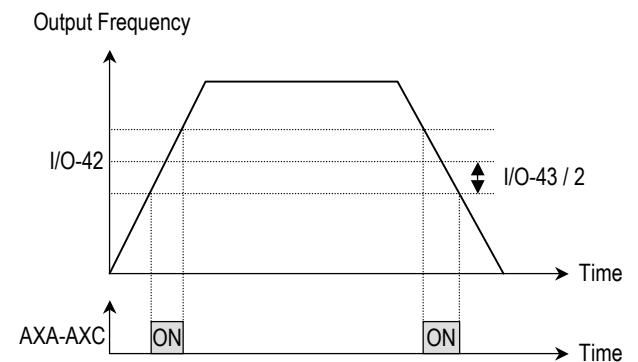

[AXA-AXC configured as 'FDT-3']

[FDT-4]

AXA-AXC is CLOSED when the output frequency reaches the FDT frequency. The output is OPENED when the output frequency goes below the FDT bandwidth centered on the FDT frequency.

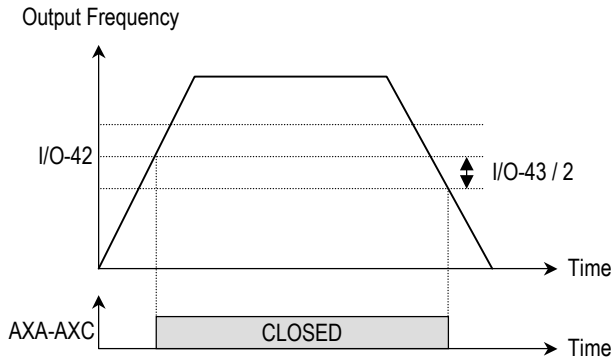

[AXA-AXC configured as 'FDT-4']

[FDT-5]

This is the inverted output of [FDT-4].

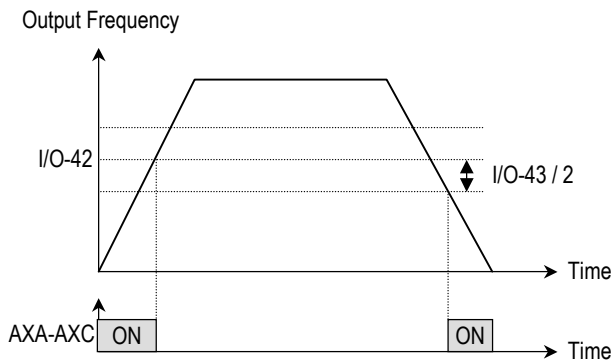

[AXA-AXC configured as 'FDT-5']

[OL]

AXA-AXC is CLOSED when the output current has reached the FU1-54 [Overload Warning Level] for the FU1-55 [Overload Warning Time].

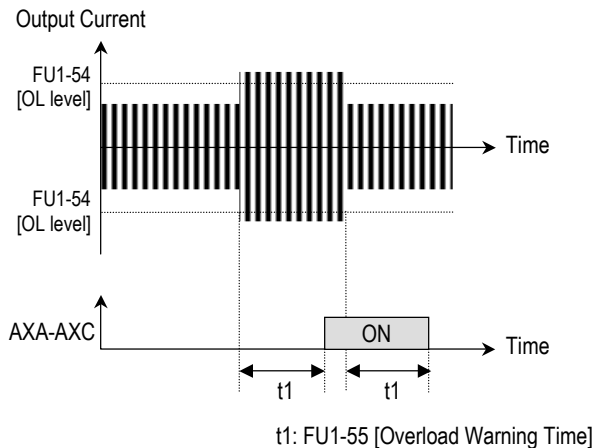

[[AXA-AXC configured as 'OL']

Related Functions: FU1-54 [Overload Warning Level]
FU1-55 [Overload Warning Time]

[IOL]

AXA-AXC is CLOSED when the output current is above the 150% of rated inverter current for 36 seconds. If this situation is continued for one minute, the inverter will cut off its output and displays 'IOL' (Inverter overload) Trip. See the nameplate for the rated inverter current.

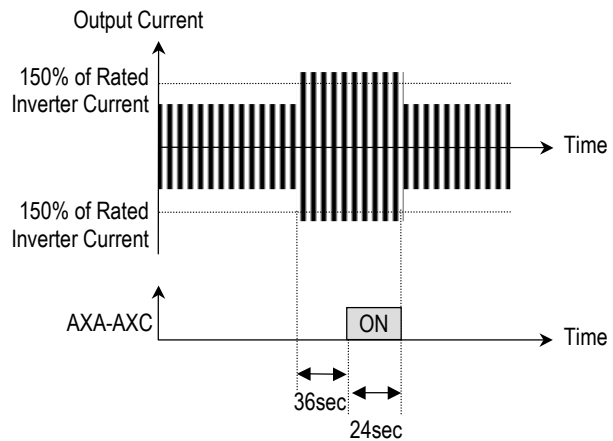

[AXA-AXC configured as 'IOL']

[Stall]

AXA-AXC is CLOSED when the inverter is on the stall prevention mode.

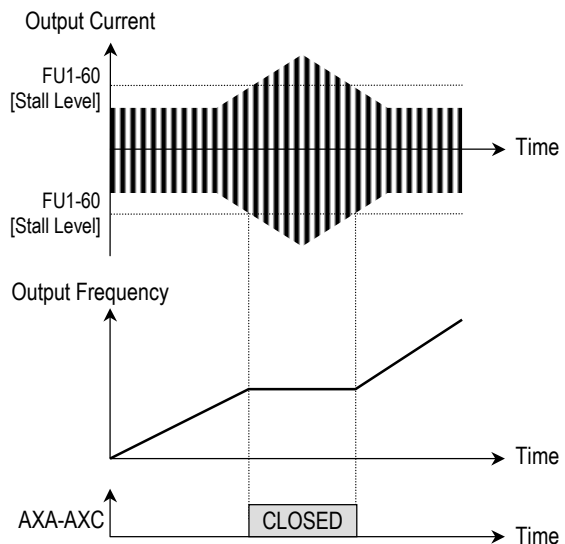

[AXA-AXC configured as 'Stall']

Related Functions: FU1-59 [Stall Prevention Mode]
FU1-60 [Stall Prevention Level]

[OV]

AXA-AXC is CLOSED when the DC link voltage is above the Over-voltage level.

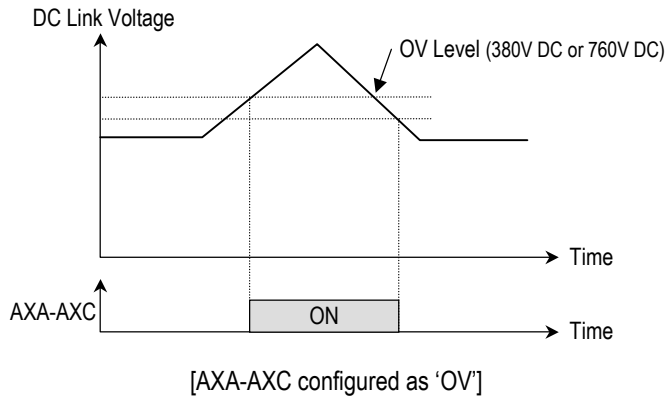

[LV]

AXA-AXC is CLOSED when the DC link voltage is below the Low-voltage level.

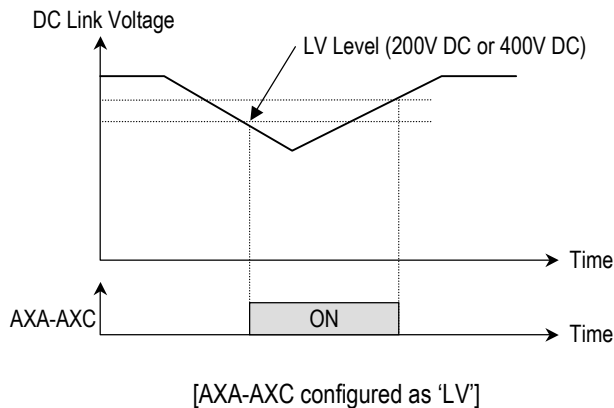

[OH]

AXA-AXC is CLOSED when the heat sink of the inverter is above the reference level.

[Lost Command]

AXA-AXC is CLOSED when frequency reference is lost.

Related Functions: I/O-11 [Criteria for Analog Signal Loss]
I/O-48 [Operating Method at Signal Loss]
I/O-49 [Waiting Time for Time Out]

[Run]

AXA-AXC is CLOSED when the inverter is running.

[Stop]

AXA-AXC is CLOSED when the inverter is stopped.

[INV line, COMM line]

This function is used in conjunction with 'Exchange' function of multi-function input for commercial line exchange. To use both signal of 'INV line' and 'COMM line', the optional Sub-A or Sub-C board must be installed.

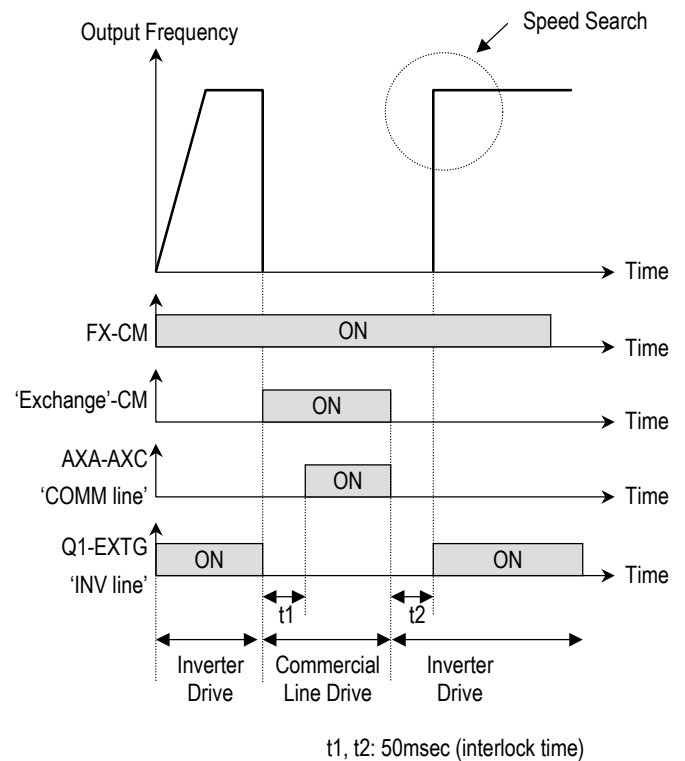

[AXA-AXC configured as 'COMM line' and 'Q1' as INV line]

Related Functions: I/O-12 ~ I/O-14 [Multi-function input]
- [Exchange]

[Ssearch]

AXA-AXC is CLOSED during the inverter is speed searching.

[Step pulse]

When Auto (Sequence) operation is selected in I/O-50, AXA-AXC outputs pulse signals on every step.

Related Functions: I/O-50 ~ I/O-84 [Auto Operation]

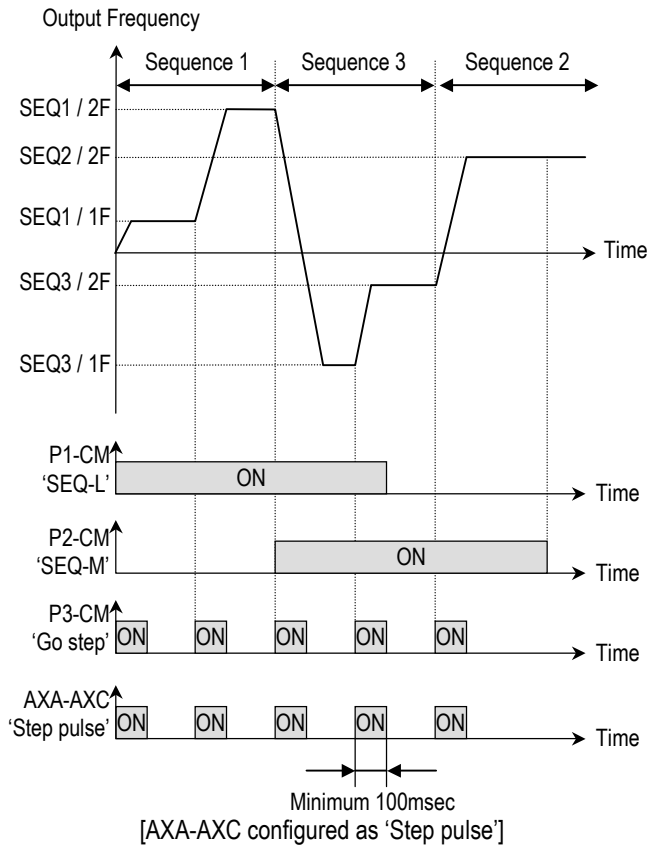

[Seq pulse]

When Auto (Sequence) operation is selected in I/O-50, AXA-AXC outputs pulse signals on the last step.

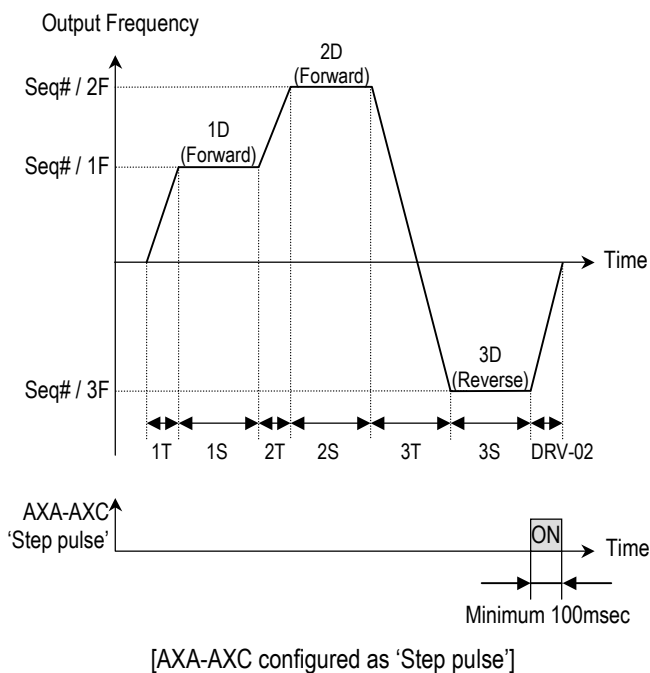

[Ready]

AXA-AXC is CLOED when the inverter is ready to run.

[Trv. ACC]

CLOSED when output frequency reaches Accel frequency.

[Trv. DEC]

CLOSED when output frequency reaches Decel frequency.

[MMC]

Automatically set to 'MMC' when 'MMC' is selected in APP-01.

[Zspd Dect]

0 Rpm detection signal during vector control

[Torq Dect]

Torque detection signal during vector and sensorless control.

I/O-45: Fault Output Relay (30A, 30B, 30C)

I/O ▶ Relay mode	45	010
45	010	

Factory Default:	010	010
------------------	-----	------------

This function is used to allow the fault output relay to operate when a fault occurs. The output relay terminal is 30A, 30B, 30C where 30A-30C is a normally open contact and 30B-30C is a normally closed contact.

Bit	Setting	Display	Description
Bit 0 (LV)	0	000	Fault output relay does not operate at 'Low voltage' trip.
	1	001	Fault output relay operates at 'Low voltage' trip.
Bit 1 (Trip)	0	000	Fault output relay does not operate at any fault.
	1	010	Fault output relay operates at any fault except 'Low voltage' and 'BX' (inverter disable) fault.
Bit 2 (Retry)	0	000	Fault output relay does not operate regardless of the retry number.
	1	100	Fault output relay operates when the retry number set in FU2-26 decreases to 0 by faults.

☞ When several faults occurred at the same time, Bit 0 has the first priority.

Related Functions: DRV-12 [Fault Display]
FU2-26 [Retry number]

I/O-46: Inverter Number
I/O-47: Baud Rate

I/O▶ Inv No. 46	1	46	1
Factory Default:	1		1

This code sets the inverter number. This number is used in communication between inverter and communication board.

I/O▶ Baud rate 47	9600 bps	47	9600
Factory Default:	9600		9600

This code sets the communication speed. This is used in communication between inverter and communication board.

I/O-48: Operating at Loss of Freq. Reference
I/O-49: Waiting Time after Loss of Freq. Reference

I/O▶ Lost command 48	None	48	0
Factory Default:	None		0

There are two kinds of loss of frequency reference. One is the loss of digital frequency reference and the other is of analog frequency reference.

Loss of digital frequency reference is applied when DRV-04 [Frequency Mode] is set to 'Keypad-1' or 'Kepad-2'. At this time, the 'Loss' means the communication error between inverter and keypad or communication board during the time set in I/O-49.

Loss of analog frequency reference is applied when DRV-04 [Frequency Mode] is set to other than 'Keypad-1' or 'Kepad-2'. At this time, the 'Loss' is determined by the criteria set in I/O-11 [Criteria for Analog Input Signal Loss].

Setting Range		Description
LCD	7-Seg	
None	0	Inverter keeps on operating at the previous frequency.
FreeRun	1	Inverter cuts off its output.

(Coast to stop)		
Stop	2	Inverter stops with Decel time (DRV-02) and Decel pattern (FU1-26).

I/O▶ Time out 49	1.0 sec	49	1.0
Factory Default:	1.0 sec		1.0

This is the time inverter determines whether there is a frequency reference or not. If there is no frequency reference satisfying I/O-11 during this time, inverter determines that it has lost of frequency reference.

Related Functions: DRV-04 [Frequency Mode]
 I/O-11 [Criteria for Analog Signal Loss]

I/O-50: Auto (Sequence) Operation
I/O-51: Sequence Number Selection (Seq #)
I/O-52: The Number of Steps of Sequence #

I/O▶ Auto mode 50	None	50	0
Factory Default:	None		0

There are two modes of 'Auto-A' and 'Auto-B' in Auto mode. Auto operation is activated by the multi-function input terminals set to [SEQ-L], [SEQ-M], [SEQ-H] and [Go step] in I/O-12 ~ I/O-14.

I/O▶ Seq select 51	3	51	1
Factory Default:	1		1

This code selects the sequence to set frequency, transient time, steady speed time and motor direction the steps.

I/O▶ Step number 52	2	52	2
Factory Default:	2		2

This code sets the number of steps to use for the sequence number selected in I/O-51.

[Auto-A]

This mode will allow the inverter to operate automatically followed by its pre-programmed sequence. According to this sequence, eight different steps of Frequency, Transient Time, Steady Speed time and Motor Direction can be initiated with only a single multi-function input contact closure (I/O-12 ~ I/O-14). The sequence and steps are set in I/O-51 ~ I/O-84.

Step Frequency	Parameter Code	Speed-H (P3)	Speed-M (P2)	Speed-L (P1)
Sequence 1	I/O-50 ~ I/O-84	0	0	1
Sequence 2		0	1	0
Sequence 3		1	0	0
Sequence 4		0	1	1
Sequence 5		1	0	1

0: OFF, 1: ON

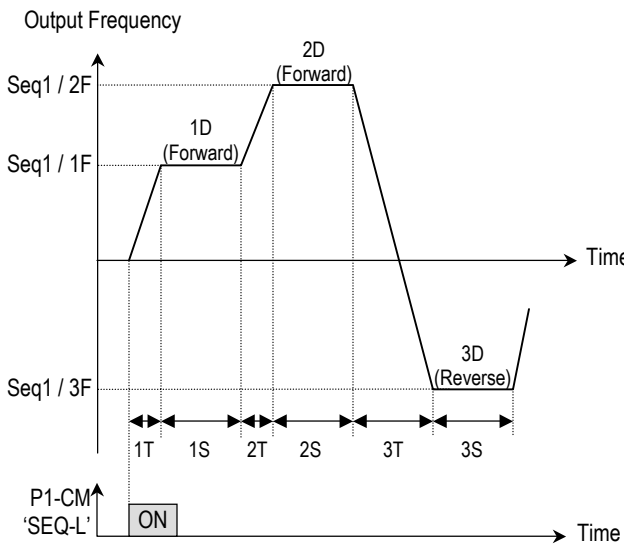

[Example 1 of 'Auto-A' operation]

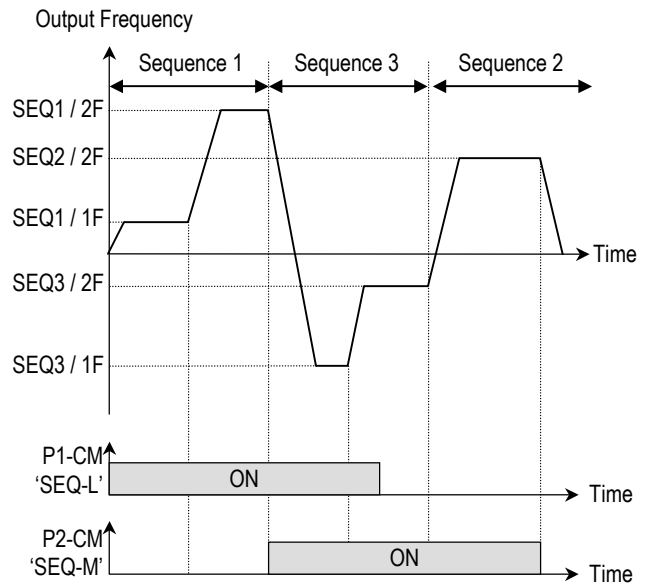

[Example 2 of 'Auto-A' operation]

[AUTO B]

This mode can be also used to program up to 8 different steps as Auto A. However, to switch from one step to another, an external contact closure set to 'Go step' is required.

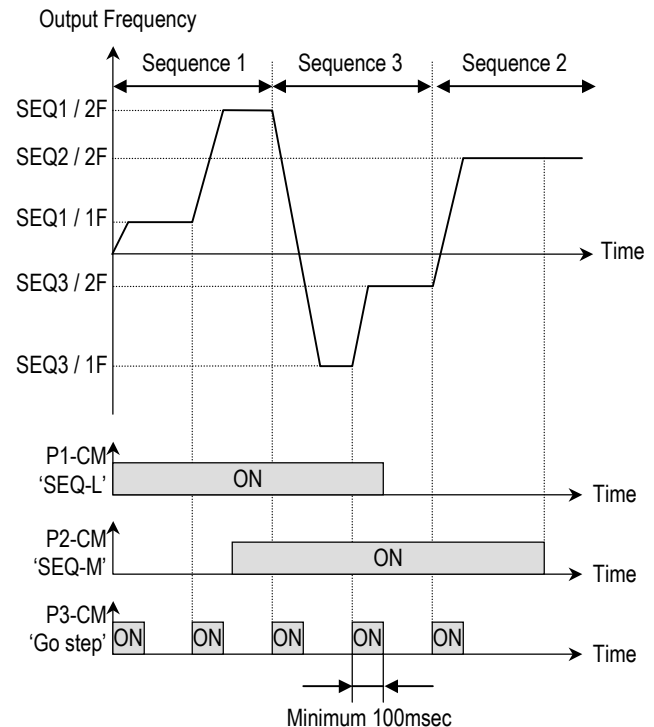

[Example of 'Auto-B' operation]

☞ **Note:** When a new sequence is selected during a sequence operating, the new sequence starts after the current sequence is finished.

I/O-53 ~ I/O-84: Frequency, Transient Time, Steady Speed Time, Motor Direction setting of each Step and Sequence

These parameter codes set the frequency, transient time, steady speed time, and motor direction. These codes are displayed according to the sequence number and steps.

Notes:

6.5 External Group [EXT]

EXT group appears only when an optional Sub-Board is installed.

EXT-00: Jump to Desired Code

EXT▶	Jump code	
00		1

Factory Default: 1

Jumping directly to any parameter code can be accomplished by entering the desired code number. This code is available only with LCD keypad.

EXT-01: Sub-Board Display

EXT▶	Sub B/D	01	1
01	Sub-A		

Factory Default: Sub-A 1

This code automatically displays the types of Sub-Board installed.

Setting Range		Description
LCD	7-Seg	
Sub-A	1	This board provides three multi-function input terminals (P4, P5, P6), three multi-function output terminals (Q1, Q2, Q3), Load meter output (LM) and second input frequency reference (V2).
Sub-B	2	This board provides encoder input terminals (AOC, BOC / A+, A-, B+, B-), encoder output terminals (FBA, FBB) and power terminals (+5V input, Vcc output).
Sub-C	3	This board provides three multi-function input terminals (P4, P5, P6), one multi-function output terminal (Q1), isolated second input frequency reference (V2) and two analog meters (AM1, AM2).
Sub-D	4	Three multi-function input terminals (P4, P5, P6), two multi-function output terminals (Q1, Q2), Encoder input signal A, B (LD/Open collector), isolated second input frequency reference (V2) and Pulse frequency reference

See 'Chapter 7 - Options' for more detail function, wiring, and terminal descriptions.

EXT-02 ~ EXT-04: Multi-Function Input Terminal Define (P4, P5, P6) – Sub-A, Sub-C

EXT▶	P4 define	02	17
02	XCEL-L		

Factory Default: XCEL-L 17

An optional Sub-Board is needed if an application requires more than three multi-function input terminals. 'Sub-A' and 'Sub-C' boards provide additional three multi-function terminals. These terminals are used in conjunction with P1, P2 and P3 terminals. Refer to I/O-12 ~ I/O-14 for use. The following table shows the terminal definitions.

Setting Range		Description
LCD	7-Seg	
Speed-L	0	Multi-Step Speed - Low
Speed-M	1	Multi-Step Speed - Mid
Speed-H	2	Multi-Step Speed - High
XCEL-L	3	Multi-Accel/Decel - Low
XCEL-M	4	Multi-Accel/Decel - Mid
XCEL-H	5	Multi-Accel/Decel - High
Dc-brake	6	DC injection braking during stop
2nd Func	7	Exchange to 2 nd functions
Exchange	8	Exchange to commercial power line
iTerm Clear	9	Reserved for future use
Up	10	Up drive
Down	11	Down drive
3-Wire	12	3 wire operation
Ext Trip-A	13	External trip A
Ext Trip-B	14	External trip B
iTerm Clear	15	Used for PID control
Open-loop	16	Exchange between PID mode and V/F mode
Main-drive	17	Exchange between Option and Inverter
Analog hold	18	Hold the analog input signal
XCEL stop	19	Disable accel and decel
P Gain2	20	Used for PID control
SEQ-L	21	Sequence operation - Low
SEQ-M	22	Sequence operation - Mid
SEQ-H	23	Sequence operation - High
Manual	24	Exchange between Sequence operation and Manual operation
Go step	25	Triggering Sequence operation (Auto-B)
Hold step	26	Hold last step (Auto-A)
Trv Off.Lo	27	Used for Traverse Operation
Trv Off.Hi	28	
Interlock1	29	Used for MMC operation
Interlock2	30	

Related Functions: DRV-04 [Frequency Mode]
I/O-01 ~ I/O-05 [V1 Adjustment]

EXT-12: Usage of Pulse Input Signal – Sub-B

EXT▶ F mode 14 None	14	0
Factory Default: None		0

This function is to select the usage of encoder pulse signal of 'Sub-B' board. The pulse signal from encoder can be used as the motor speed feedback or frequency reference. When 'Sub-B' board is installed, FU2-40 must be set to 'V/F'.

[None]

The encoder pulse signal is not used.

[Feed-back]

The encoder pulse signal is used as the motor speed feedback. The inverter can maintain the motor speed constantly, regardless of the load fluctuation, by using the encoder feedback. The encoder pulse related functions must be set correctly for better performance in EXT-15 ~ EXT-24.

Related Functions: EXT-15 [Pulse Input Signal selection]
EXT-16 [Encoder Pulse Number]
EXT-22 [P-Gain for 'Sub-B']
EXT-23 [I-Gain for 'Sub-B']
EXT-24 [Slip Frequency for 'Sub-B']

[Reference]

The encoder pulse signal is used as the frequency reference. When this function is selected, the frequency reference selected in DRV-04 is ignored. Reference Frequency versus Pulse Input Curve can be made by four parameters of EXT-18 ~ EXT-20.

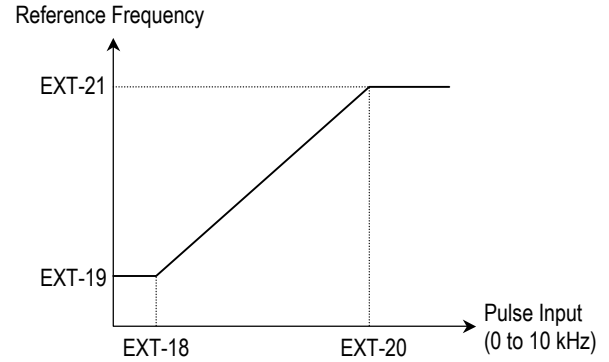

[Reference Frequency vs. Pulse Input]

Related Functions: EXT-15 [Pulse Input Signal selection]
EXT-17 [Filtering Time Constant]
EXT-18 [Minimum Pulse Frequency]
EXT-19 [Minimum Output Frequency]
EXT-20 [Maximum Pulse Frequency]
EXT-21 [Maximum Output Frequency]

EXT-13: Real Motor Speed Direction

EXT▶ RealSpdDir 13 None	13	0
Factory Default: None		0

If EXT-12 is set to 1 Feed-back with SUB-B mounted, motor rotation direction is displayed in this parameter.

EXT-14: Encoder Feedback Frequency

EXT▶ ENC Feedback 14 None	14	0
Factory Default: None		0

Read frequency regardless of control mode if SUB-B is installed with EXT-12 set to Feed-back.

EXT-15: Pulse Input Signal Selection – Sub-B

EXT▶ F pulse set 15 A + B	15	0
Factory Default: A + B		0

This code sets the encoder pulse to use. [A+B] uses two encoder signal lines of A and B, and [A] uses one encoder signal line of A or B. -[A+B] is used when encoder and mot or rotation direction is opposite.

EXT-16: Encoder Pulse Number – Sub-B

EXT▶ F pulse num	16	1024
16 1024		

Factory Default: 1024 **1024**

This code sets the encoder pulse per rotation of encoder.

EXT-17: Filtering Time Constant for Pulse Input Signal – Sub-B

EXT▶ F filter	17	10
17 10 ms		

Factory Default: 10 ms **10**

This is the filtering time constant of pulse input signal. This is used to make the inverter respond slowly to the pulse input signal when the EXT-14 is set to 'Reference'.

EXT-18 ~ EXT-21: Pulse Input Signal Adjustment – Sub-B

This is used to adjust the pulse input signal when the pulse input through Sub-B board references the frequency. This function is applied when EXT-14 is set to 'Reference'. Reference Frequency versus Analog Voltage Input Curve can be made by four parameters of EXT-18 ~ EXT-21.

EXT▶ F pulse x1	18	0.0
18 0.0 kHz		

Factory Default: 0.0 kHz **0.0**

This is the minimum pulse frequency at which the inverter outputs minimum frequency.

EXT▶ F freq y1	19	0.00
19 0.00 Hz		

Factory Default: 0.00 Hz **0.00**

This is the minimum frequency the inverter outputs when there is the minimum pulse frequency (EXT-18).

EXT▶ F pulse x2	20	10.0
20 10.0 kHz		

Factory Default: 10.0 kHz **10.0**

This is the maximum pulse frequency at which the inverter outputs maximum frequency.

EXT▶ F freq y2	21	60.00
21 60.00 Hz		

Factory Default: 60.00 Hz **60.00**

This is the maximum frequency the inverter outputs when there is the maximum pulse frequency (EXT-20).

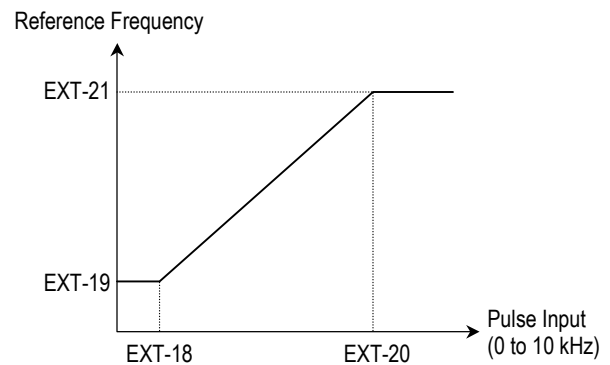

[Reference Frequency vs. Pulse Input]

EXT-22 ~ EXT-23: Gains for 'Sub-B' Board

EXT▶ PG P-gain	22	3000
22 3000		

Factory Default: 3000 **3000**

This is the proportional gain when the EXT-14 is set to 'Feed-back'.

EXT▶ PG I-gain	23	300
23 300		

Factory Default: 300 **300**

This is the integral gain when the EXT-14 is set to 'Feed-back'.

EXT-24: Slip Frequency for 'Sub-B' Board

EXT▶ PG Slip Freq 24 100 %	24	100
Factory Default: 100 %		100

This is the limit frequency the inverter uses to compensate the motor speed drop due to load fluctuation. The set point value is the percentage of FUN-32 [Rated Motor Slip].

**EXT-25: P Gain for Sensored Vector_SPD
EXT-25: I Gain for Sensored Vector_SPD
EXT-27: Forward Torque Limit
EXT-28: Reverse Torque Limit**

EXT▶ ASR P-gain 25 100 %	25	150
Factory Default: 150 %		150

EXT▶ ASR I-gain 26 200 ms	26	200
Factory Default: 200 ms		200

EXT▶ TRQ + Limit 27 100 %	27	150
Factory Default: 150 %		150

EXT▶ TRQ - Limit 28 100 %	28	150
Factory Default: 150 %		150

EXT-30 ~ EXT-32: Multi-Function Output Terminal (Q1, Q2, Q3) Define – Sub-A, Sub-C

Q1, Q2, Q3 terminals are provided on Sub-A and Sub-C board as an open collector output. The functions of these terminals can be selected the same as I/O-44 [Multi-function Auxiliary Contact Output Define].

EXT▶ Q1 define 30 FDT-1	30	0
---------------------------------------	-----------	----------

Factory Default: FDT-1		0
---------------------------	--	----------

EXT▶ Q2 define 31 FDT-2	31	1
---------------------------------------	-----------	----------

Factory Default: FDT-2		1
---------------------------	--	----------

EXT▶ Q3 define 32 FDT-3	32	2
---------------------------------------	-----------	----------

Factory Default: FDT-3		2
---------------------------	--	----------

Related Functions: FU1-54 [Overload Warning Level]
FU1-55 [Overload Warning Time]
FU1-59 [Stall Prevention Mode]
FU1-60 [Stall Prevention Level]
I/O-12 ~ I/O-14 [Multi-function Input Terminal define]
I/O-42 ~ I/O-43 [Frequency Detection]
I/O-44 [Multi-function Auxiliary Contact Output define]
I/O-50 ~ I/O-56 [Auto Operation]

**EXT-34: LM (Load Meter) Output – Sub-A
EXT-35: LM Adjustment**

EXT▶ LM mode 34 Current	34	1
---------------------------------------	-----------	----------

Factory Default: Current		1
-----------------------------	--	----------

EXT▶ LM Adjust 35 100 %	35	100
---------------------------------------	-----------	------------

Factory Default: 100 %		100
---------------------------	--	------------

Load meter displays the inverter output Frequency, Current, Voltage and DC link voltage with pulse signals on the LM terminal of Sub-A board. The average ranges from 0V to 10V. EXT-35 is used to adjust the LM value.

[Frequency]

LM terminal outputs inverter output frequency. The output value is determined by,
LM Output Voltage = (Output freq. / Max. freq.) × 10V × EXT-35 / 100

[Current]

LM terminal outputs inverter output current. The output value is determined by,
 $LM\ Output\ Voltage = (Output\ current / Rated\ current) \times 10V \times EXT-35 / 150$

[Voltage]

LM terminal output inverter output voltage. The output value is determined by,
 $LM\ Output\ Voltage = (Output\ voltage / Max.\ output\ voltage) \times 10V \times EXT-35 / 100$

[DC link vtg]

LM terminal outputs the DC link voltage of inverter. The output value is determined by,
 $LM\ Output\ Voltage = (DC\ link\ voltage / Max.\ DC\ link\ voltage) \times 10V \times EXT-35 / 100$

[Torque]

FM terminal outputs the motor torque. The output value is determined by,
 $FM\ terminal\ output\ voltage = (Torque\ current / Rated\ torque\ current) \times 10V \times FM\ output\ gain (I/O-41) / 150$

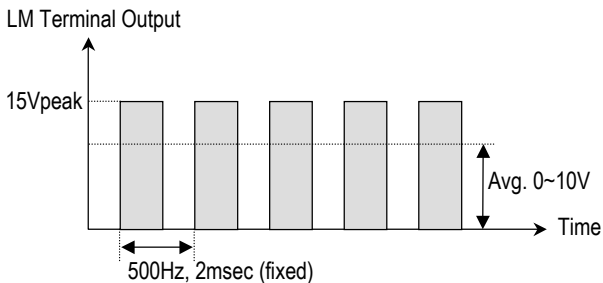

[LM Output (LM-CM terminal)]

Related Functions: I/O-40 ~ I/O-41 [FM Output]

EXT-40: AM1 (Analog Meter 1) Output – Sub-C
EXT-41: AM1 Adjustment
EXT-42: AM2 (Analog Meter 2) Output – Sub-C
EXT-43: AM2 Adjustment

These terminals are provided on Sub-C board.

EXT▶ AM1 mode 40 Frequency	40	0
-------------------------------	-----------	----------

Factory Default: Frequency	0
----------------------------	----------

EXT▶ AM1 Adjust 41 100 %	41	100
-----------------------------	-----------	------------

Factory Default: 100 %	100
------------------------	------------

EXT▶ AM2 mode 42 DC link Vtg	42	3
---------------------------------	-----------	----------

Factory Default: DC link Vtg	3
------------------------------	----------

EXT▶ AM2 Adjust 43 100 %	43	100
-----------------------------	-----------	------------

Factory Default: 100 %	100
------------------------	------------

Analog meter displays the inverter output Frequency, Current, Voltage and DC link voltage with analog voltage on the AM1 and AM2 terminals of Sub-C board. The output voltage ranges from 0V to 10V. EXT-41 and EXT-43 are used to adjust the AM output value.

[Frequency]

The AM terminal outputs inverter output frequency. The output value is determined by,
 $AM\ Output\ Voltage = (Output\ freq. / Max.\ freq.) \times 10V$

[Current]

The M terminal outputs inverter output current. The output value is determined by,
 $AM\ Output\ Voltage = (Output\ current / Rated\ current) \times 10V$

[Voltage]

The AM terminal outputs inverter output voltage. The output value is determined by,

AM Output Voltage = (Output voltage / Max. output voltage) × 10V

[DC link vtg]

The AM terminal outputs the DC link voltage of inverter.

The output value is determined by,

AM Output Voltage = (DC link voltage / Max. DC link voltage) × 10V

[Torque]

The AM terminal outputs the Torque of the motor. The output value is determined by,

AM Output Voltage = (Torque current/ Rated Torque current) * 10V* AM output gain (EXT-41~42) / 150

EXT-50~53 [Speed limit for Torque mode operation]

Related parameters : FU2-39 [Control mode selection]

FU1-20 [max Freq]

EXT-27[Trq + Limit] EXT-28[Trq - Limit]

Code	LCD display	Description	Factory setting	Setting range
EXT-50	Speed Limit	Speed Limit Level	100[%]	0 – 100[%]
EXT-51	Speed Bias	Speed Limit Bias	10[%]	0 – 200[%]
EXT-52	Speed Gain	Speed Limit Gain	1	1 – 10
EXT-53	Speed Dir	Speed Limit Direction	1 (Forward)	0 (Reverse) 1 (Forward)

By setting speed limit, this parameter prevents the motor from rotating excessively high speed due to no-load or light load connection during Vector_TRQ in FU2-39 [Control mode].

Set as the percent of EXT-50 [Speed limit level] and EXT-51 [Speed Limit Bias] to FU1-20 [Max Freq].

If EXT-53 [Speed Limit Direction]= FWD, EXT-51 [Speed Limit Bias]

FWD Torque control is set, the FWD Torque control is shown as below. In other words, when the motor rotates in Forward direction, FWD torque is kept controlled in the

range of EXT-50 [Speed Limit Level] + EXT-51 [Speed bias]. When the motor rotates in Reverse direction, REV torque is controlled in EXT-51[Speed Limit Bias] and torque is controlled constant in the above speed range. EXT-52 [Speed limit gain] is the curve value to reduce the FWD torque or to increase to the constant torque in Reverse direction.

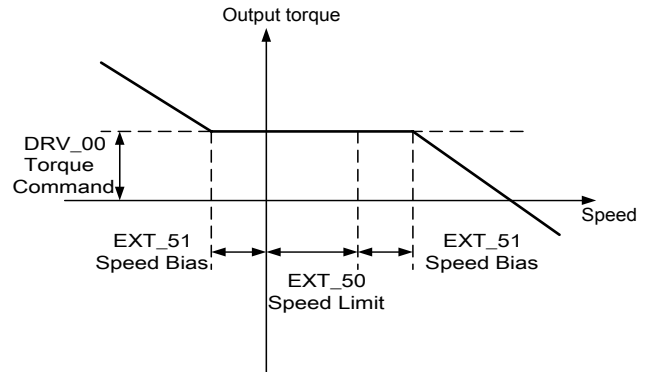

The following illustrations show the relationship between torque, motor speed and speed limit direction.

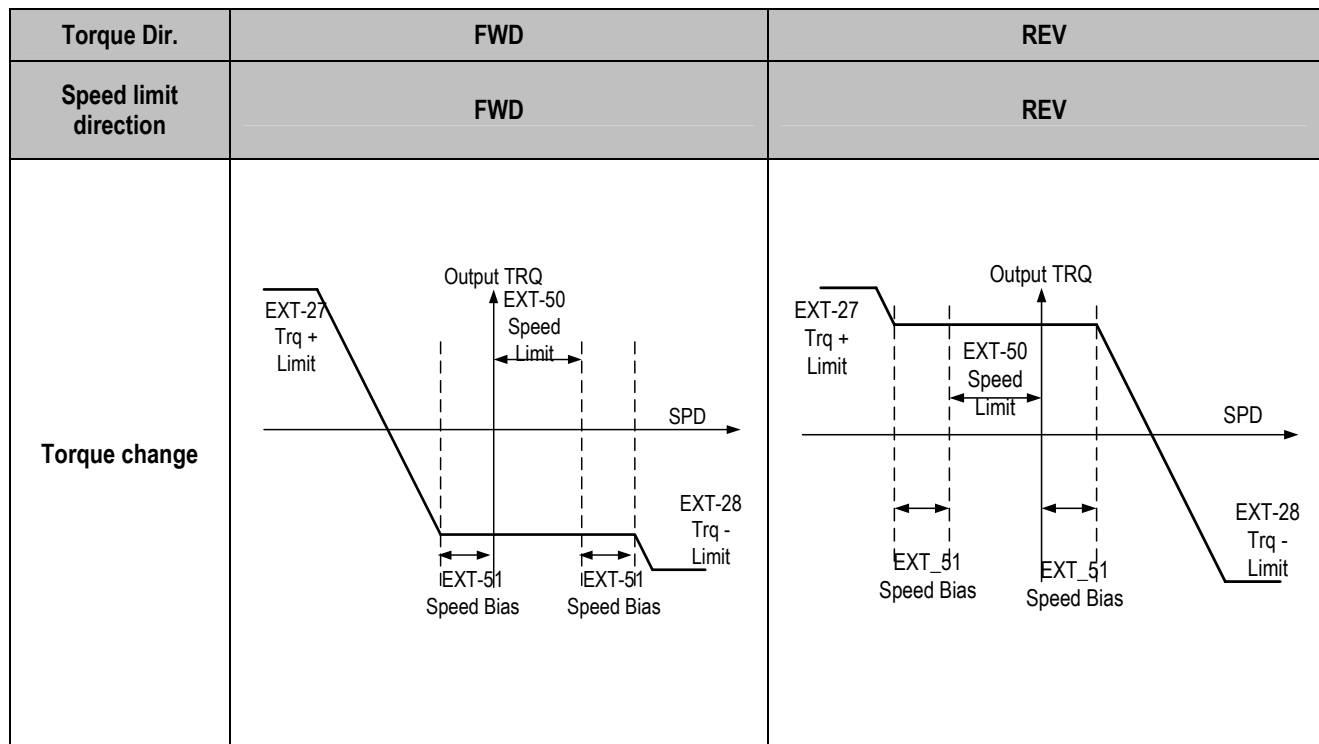
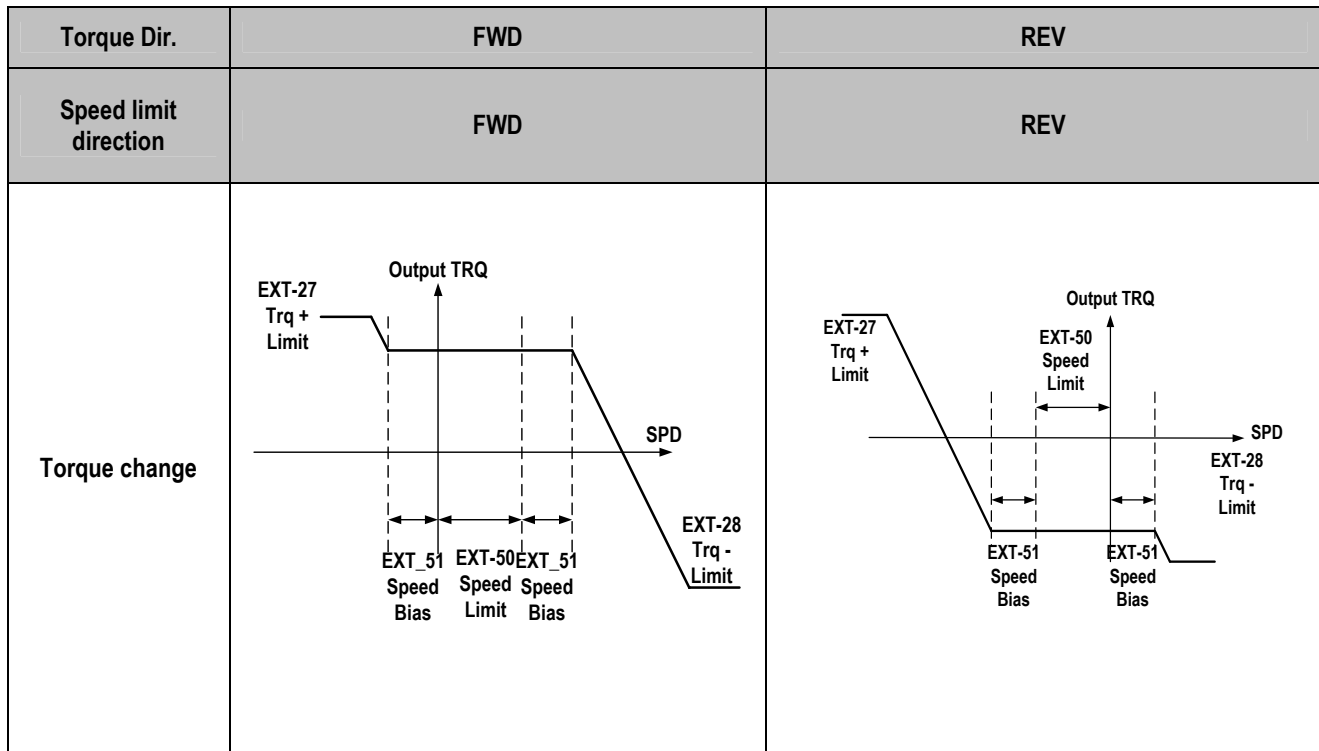

EXT-54: Zero Speed Detection Level
EXT-55: Zero Speed Detection Bandwidth

Used to set the zero speed detection (SUB-B)

- Only valid when FU2-39 [Control mode selection] is set to Vector_SPD, Vector_TRQ.
- Detect the zero speed using I/O-44 [Multi-function auxiliary contact output selection]. Set Zspd Dect in I/O-44 [Multi-function auxiliary contact output] to activate this function.

➔ Note : Sub-board is needed to use multi-function output terminal Q1,Q2,Q3.

Code	Keypad Display	Parameter Name	Factory setting	Setting range
EXT-54	ZSD Level	Zero Speed Detection Level	0.3[Hz]	0 – 120 [Hz]
EXT-55	ZSD Band	Zero Speed Detection Bandwidth	0.1[Hz]	0 – 0.3 [Hz]

Auxiliary contact relay activates as shown below if the following settings are applied to EXT-54 [Zero Speed Detection Level] and EXT-55 [Zero Speed Detection Bandwidth].

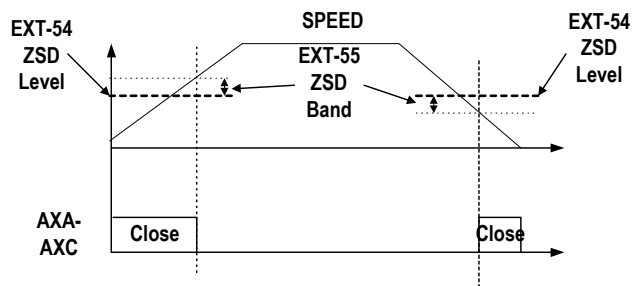

Related parameters : FU2-39 [Control mode selection]
 I/O-44 [Multi-function auxiliary contact output]

EXT-56: Torque Detection Level
EXT-57: Torque Detection Bandwidth

Use to set output torque detection (SUB-B)

- Only valid when FU2-39 [Control mode selection] is set to Vector_SPD, Vector_TRQ.
- Detect Torque using I/O-44 [Multi-function auxiliary contact output selection].

➔ Note : Sub-board should be mounted to use multi-function output terminal Q1,Q2,Q3.

Code	Keypad Display	Description	Factory setting	Setting range
EXT-56	TD Level	Torque Detection Level	100[%]	0 – 150 [%]
EXT-57	TD Band	Torque Detection Bandwidth	5[%]	0 – 10 [%]

EXT-56 [Torque Detection Level] and EXT-57 [Torque Detection Bandwidth] are activated in the following conditions as shown below.

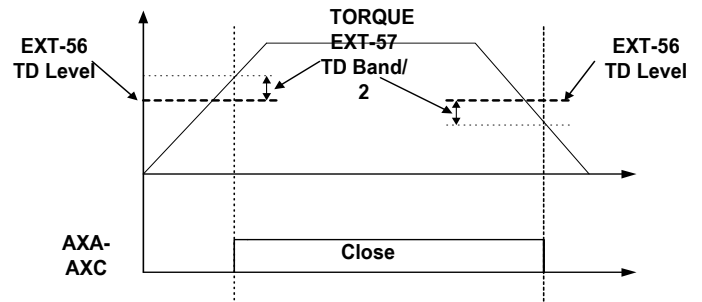

Related parameters : FU2-39 [Control mode select]
 I/O-44 [Multi-function auxiliary contact output selection]

6.6 Application Group [APP]

APP-00: Jump to desired code

APP▶ Jump code
00 1

Factory Default: 1

Jumping directly to any parameter code can be accomplished by entering the desired code number. This code is available only with LCD keypad.

APP-01: Application Mode Selection

APP▶ App. mode
01 None

01

0

Factory Default: None

This code sets the application mode.

Setting Range		Description
LCD	7-Seg	
None	0	Application mode is not selected.
Traverse	1	Traverse mode is selected in application group. Related functions (APP-02~07) are displayed.
MMC	2	MMC (Multi-Motor Control) mode is selected in application group. Related functions (APP-08~31) are displayed.
DRAW	3	DRAW mode is selected in application group. Related functions (APP-32~33) are displayed.

[Traverse]: This is a mechanism to wind thread to an intended shape on a reel with a rotary motion and reciprocation. Adjusting the speed of mechanical reciprocation can make different shapes of thread reel. The following figure shows an example. The guide should move with low speed at the center of the reel and fast at the edge of the reel.

Related Functions: APP-02 to APP-07 [Traverse Parameters]
I/O-12 to I/O-14 [Multi-Function Input]
EXT-30 to EXT-32 [Multi-Function Output]

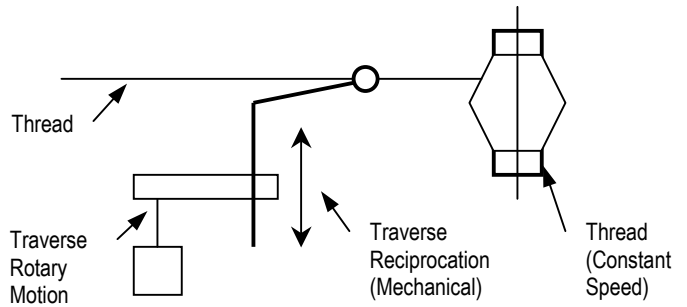

[An example of Traverse Operation]

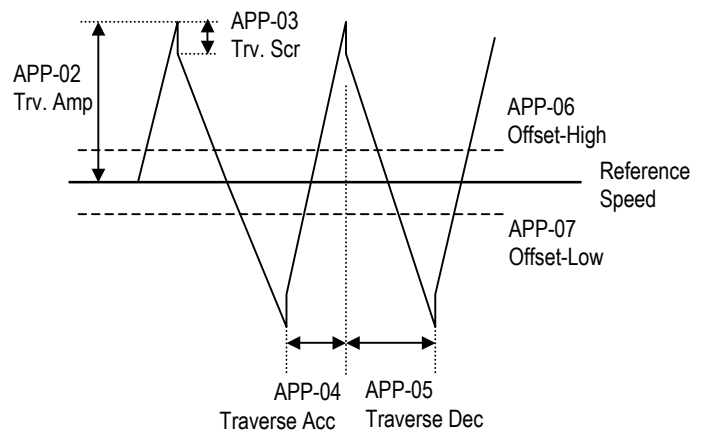

[Traverse Operation Pattern]

[MMC]: The 'PID' control should be selected in FU2-47 to use this function.

◆ One inverter can control multiple motors. This function is often used when controlling the amount and pressure of flow in fans or pumps. Built-in PI controller controls a main motor after receiving process control value and keeps the control value constant by connecting auxiliary motors to commercial line when needed.

◆ In case that flow amount or flow pressure is beyond or below the reference so the main drive cannot control by itself, auxiliary motors are automatically turned on/off. Maximum four (Q1~3 and Aux. output) auxiliary motors can be run. Each Starting and Stop Frequency should be set to four auxiliary motors.

◆ Auto Change can be selected to automatically switch the order of the running motors for keeping motor run-time constant. Set mode '1' for automatic changing of auxiliary motors only and set mode '2' for automatic changing of all

motors including main motor. For mode '2', external sequence (Refer to APP-26) should be configured.

◆ Abnormal motor can be skipped from running by using the multi-function input terminals (P1, P2, P3, and P4). If a multi-function terminal is opened, the inverter stops all running motors and restarts operation with only normal motors except the abnormal motor. (Refer to APP-29)

◆ Sleep function is initiated when flow demand is low. Inverter stops motor when the motor runs below Sleep Frequency (APP-24) during Sleep Delay Time (APP-23). While in the sleep state, inverter keeps monitoring and initiates Wake-Up function when the real value of the controlling amount has decreased below the Wake-Up level (APP-25).

☞ **Note:** Only one auxiliary motor can be connected with AUX terminal on control terminal strip without using MMC Option Board.

Related Functions: APP-08 to APP-31 [MMC Parameters]
 DRV-04 [Frequency Mode]
 FU2-47 [PID Operation Selection]
 I/O-01 to I/O-10 [Analog Signal Input]
 EXT 15 to EXT21 [Pulse Input Signal]
 I/O-12 to I/O-14 [Multi-Function Input]
 EXT-30 to EXT-32 [Multi-Function Output]

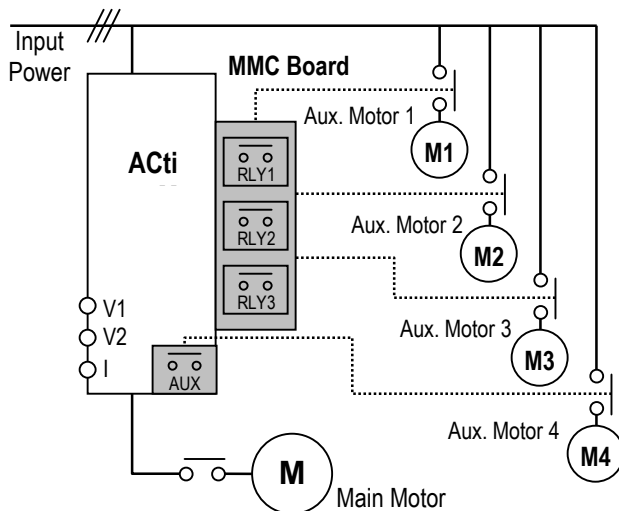

[MMC Diagram]

[Draw]: This is a kind of Open-Loop Tension Control. This is used to maintain constant tension of material with the speed difference between main motor and subordinate motor.

Related Functions: APP-32 to APP-33 [Draw Parameters]
 DRV-04 [Frequency Mode]
 I/O-01 to I/O-10 [Analog Signal Input]
 EXT 06 to EXT-10 [Analog Input Setting]
 I/O-12 to I/O-14 [Multi-Function Input]
 EXT-02 to EXT-04 [Multi-Function Input]

APP-02: Traverse Amplitude

APP▶Trv. Amp [%] 02 0.0%	02	0.0
Factory Default:	0.0%	0.0

This code sets the frequency amplitude of traverse operation. The value is the percentage of reference frequency. The output value is determined by,
 $Trv. Amp Frequency = (Reference Freq. * Trv. Amp)/100$

APP-03: Traverse Scramble Amplitude

APP▶Trv. Scr [%] 03 0.0%	03	0.0
Factory Default:	0.0%	0.0

This code sets the frequency amplitude of scramble operation. The output value is determined by,
 $Trv. Scr Frequency = (Trv. Amp Frequency * (100 - Trv. Scr))/100$

APP-04: Traverse Accel Time
APP-05: Traverse Decel Time

APP▶Trv Acc Time 04 2.0 sec	04	2.0
Factory Default:	2.0 sec	2.0

APP▶Trv Dec Time 05 3.0 sec	05	3.0
Factory Default:	3.0 sec	3.0

Sets the acceleration and deceleration time for traverse operation.

- ☞ The 'Trv Acc' terminal set in EXT-30 to EXT-32 is ON during traverse acceleration time. (Open Collector Output)
- ☞ The 'Trv Dec' terminal set in EXT-30 to EXT-32 is ON during traverse deceleration time. (Open Collector Output)
- ☞ APP-04 and APP-05 should be set to a value less than APP-03. If not, traverse control does not accomplished correctly.

APP-06: Traverse Offset (Hi) Setting
APP-07: Traverse Offset (Lo) Setting

APP▶ Trv Off Hi 06 0.0 %	06	0.0
Factory Default:	0.0 %	0.0

This code makes positive offset during traverse operation by multi-function input terminal. When the 'Trv Off Hi' terminal is ON, the offset frequency is added to the reference frequency. To use this function, set a terminal out of multi-function input terminals (P1, P2, P3) to 'Trv Off Hi' in I/O-12 ~ I/O-14. The offset value is determined by, Trv. Off Hi Frequency =(Reference Frequency * Trv. Off Hi)/100

APP▶ Trv Off Lo 07 0.0 %	07	0.0
Factory Default:	0.0 %	0.0

This code makes negative offset during traverse operation by multi-function input terminal. When the 'Trv Off Lo' terminal is ON, the offset frequency is subtracted from the reference frequency. To use this function, set a terminal out of multi-function input terminals (P1, P2, P3) to 'Trv Off Lo' in I/O-12 ~ I/O-14. The offset value is determined by, Trv. Off Lo Frequency =(Reference Frequency * Trv. Off Lo)/100

APP-08: Running Auxiliary Motor Number Display

APP▶Aux Mot Run 08 0	08	0
Factory Default:	0	0

This code shows how many auxiliary motors are running by MMC control.

APP-09: Starting Auxiliary Motor Selection

APP▶Starting Aux 09 1	09	1
Factory Default:	1	1

This code sets the starting auxiliary motor for MMC control.

APP-10: Operation Time Display on Auto Change

APP▶Auto Op Time 10 00:00	10	00:00
Factory Default:	00:00	00:00

This code displays the operation time after Auto Change is accomplished.

APP-11: Start Frequency of Aux. Motor 1
APP-12: Start Frequency of Aux. Motor 2
APP-13: Start Frequency of Aux. Motor 3
APP-14: Start Frequency of Aux. Motor 4

APP▶Start freq1 11 49.99 Hz	11	49.99
Factory Default:	49.99 Hz	49.99

APP▶Start freq2 12 49.99 Hz	12	49.99
Factory Default:	49.99 Hz	49.99

APP▶Start freq3 13 49.99 Hz	13	49.99
-------------------------------------	-----------	--------------

Factory Default: 49.99 Hz **49.99**

APP▶Start freq4 14 49.99 Hz	14	49.99
-------------------------------------	-----------	--------------

Factory Default: 49.99 Hz **49.99**

The inverter turns on AUX, RLY1, RLY2, and RLY3 in order if the output frequency is over the frequencies set in APP-11 to APP-14, respectively, and the time is over APP-19.

APP-15: Stop Frequency of Aux. Motor 1
APP-16: Stop Frequency of Aux. Motor 2
APP-17: Stop Frequency of Aux. Motor 3
APP-18: Stop Frequency of Aux. Motor 4

APP▶Stop freq1 15 15.00 Hz	15	15.00
------------------------------------	-----------	--------------

Factory Default: 15.00 Hz **15.00**

APP▶Stop freq2 16 15.00 Hz	16	15.00
------------------------------------	-----------	--------------

Factory Default: 15.00 Hz **15.00**

APP▶Stop freq3 17 15.00 Hz	17	15.00
------------------------------------	-----------	--------------

Factory Default: 15.00 Hz **15.00**

APP▶Stop freq4 18 15.00 Hz	18	15.00
------------------------------------	-----------	--------------

Factory Default: 15.00 Hz **15.00**

The inverter turns off RLY3, RLY2, RLY1, and AUX in order if the output frequency is below the frequencies set in APP-15 to APP-18, respectively, and the time is over APP-20.

APP-19: Delay Time before Operating Aux. Motor
APP-20: Delay Time before Stopping Aux. Motor

APP▶Aux Start DT 19 60.0 sec	19	60.0
--------------------------------------	-----------	-------------

Factory Default: 60.0 sec **60.0**

Sets the time the inverter waits before starting the auxiliary motors.

APP▶Aux Stop DT 20 60.0 sec	20	60.0
-------------------------------------	-----------	-------------

Factory Default: 60.0 sec **60.0**

Sets the time the inverter waits before stopping the auxiliary motors.

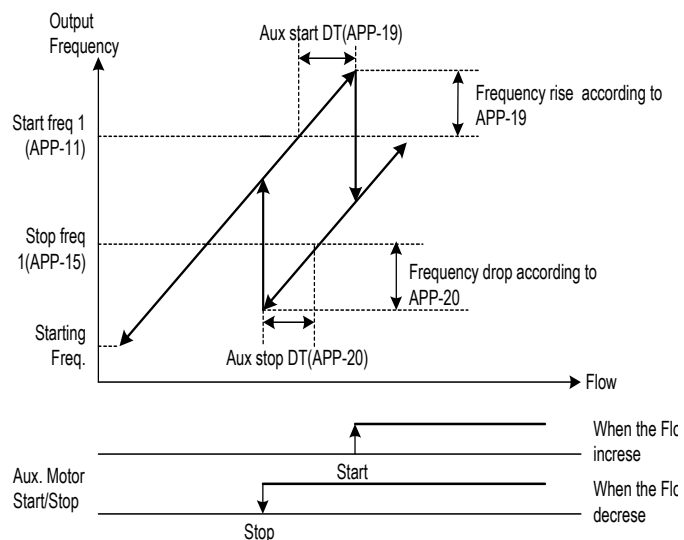

[Aux. Motor Start/Stop with MMC]

APP-21: The Number of Aux. Motors

APP▶Nbr Aux's 21 4	21	4
----------------------------	-----------	----------

Factory Default: 4 **4**

Sets the number of auxiliary motors connected to the inverter.

APP-22: PID Bypass Selection

APP▶Regul Bypass
22 --- No ---

22

0

Factory Default: No **0**

This is used to bypass the PID operation selected in FU2-47. Select this code to 'Yes' when using MMC function without PID control. The frequency is determined by real value of control amount instead PID controller output. The real value is also used as the Start/Stop reference of Aux. motors.

The following figure shows the running pattern with this function applied for controlling the flow rate of a tank. To control the flow rate according to the water level of a tank, divide the water level of the tank into the region to the number of Aux. motors plus one, and map each region from starting frequency to maximum frequency. The inverter increases output frequency to lower the water level in the tank when the water level in the tank rises. When reaching maximum frequency, inverter connects aux. motors connected directly to commercial line. After connecting aux. motor, inverter starts again from the starting frequency. By selecting APP-22 to 'Yes', PID operation is disabled and Control Mode (FU2-47) is changed to 'V/F'. PID Bypass is available only when Freq. Mode (DRV-04) is set to 'V1', '1' or 'V2'. The level in a tank can be checked in APP-30 [Actual Value] and APP-31 [Actual Percent].

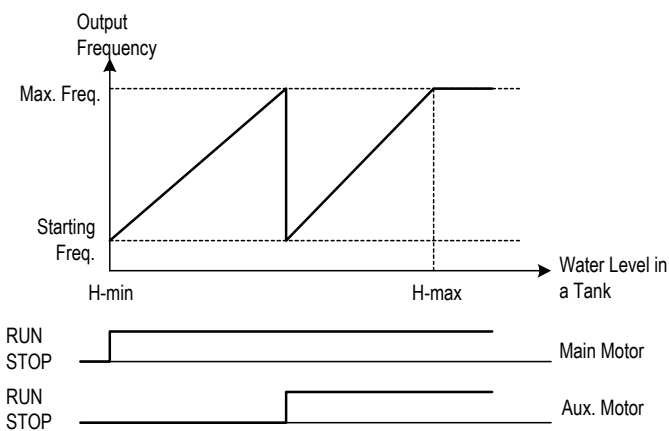

[Aux. Motor Start/Stop without PID Control]

APP-23: Sleep Delay Time

APP-24: Sleep Frequency

APP-25: Wake-Up Level

APP▶Sleep Delay
23 60.0 sec

23

60.0

Factory Default: 60.0 sec **60.0**

APP▶Sleep Freq
24 19.00 Hz

23

19.00

Factory Default: 19.00 Hz **19.00**

APP▶WakeUp level
25 35 %

25

35

Factory Default: 35 % **35**

Sleep function is initiated when flow demand is low. Inverter stops motor when the motor runs below Sleep Frequency (APP-24) during Sleep Delay Time (APP-23). While in the sleep state, inverter keeps monitoring and initiates Wake-Up function when the real value of the controlling amount has decreased below the Wake-Up level (APP-25).

Note: Sleep function is not operated if the Sleep Delay Time (APP-23) is set to '0'.

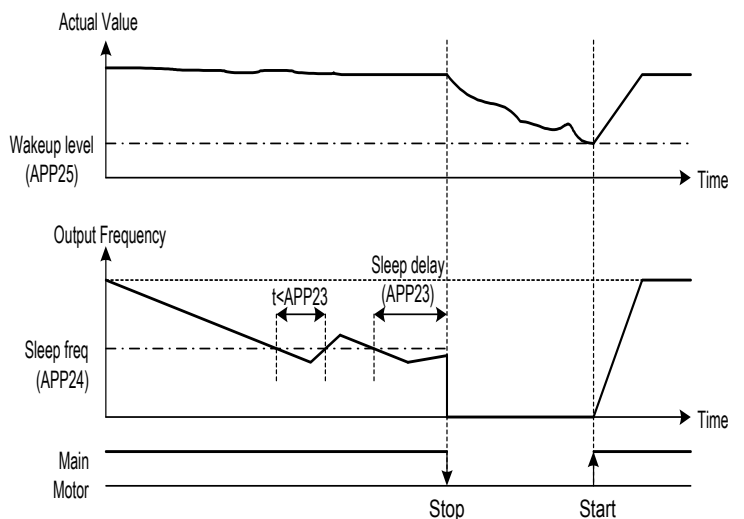

[Sleep Operation]

APP-26: Auto Change Mode Selection

APP▶AutoCh_Mode 26	0	26	0
Factory Default:	0		0

This function is used to change the running order of the motors to regulate their run-time when multiple motors are connected for MMC.

[0]: Not using Auto Change Function.
The inverter keeps the order Main motor ⇒ RLY1 ⇒ RLY2 ⇒ RLY3 ⇒ AUX and do not change the running order of auxiliary motors.

[1]: Auto Change Function is applied only to aux. motors.
The inverter changes the order of auxiliary motors except the main motor connected to the drive. Running order is Main Motor ⇒ RLY1 ⇒ RLY2 ⇒ RLY3 ⇒ AUX. And then it is changed to Main Motor ⇒ RLY2 ⇒ RLY3 ⇒ AUX ⇒ RLY1.

[2]: Auto Change Function is applied to all motors. The inverter changes the order of all motors. The inverter operates the initial motor and the others are directly powered by commercial line. It should be used with Inter-lock function after configuring external inter-lock sequence circuit as shown below.

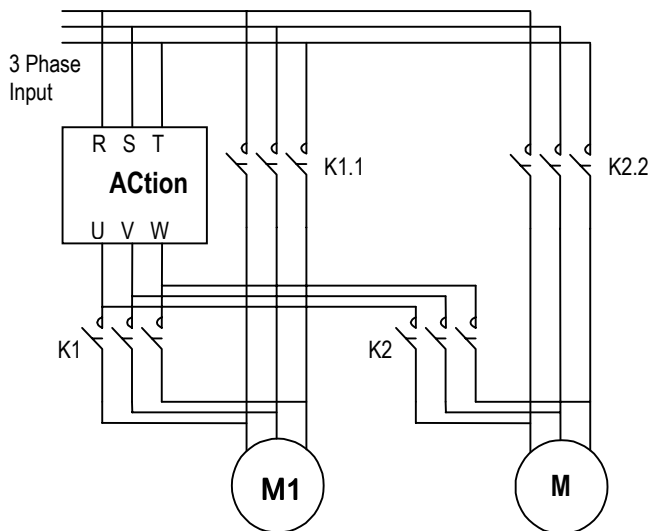

[Wiring Diagram for Inter-Lock Configuration]

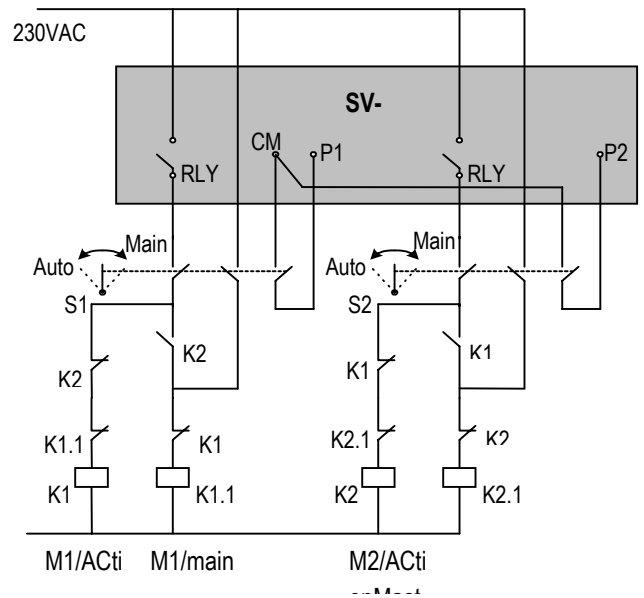

[Sequence Circuit for Inter-Lock Configuration]

APP-27: Auto Change Time
APP-28: Auto Change Level

APP▶AutoEx-intv 27	72:00	27	72:00
Factory Default:	72:00		72:00

APP▶AutoEx-level 28	20 %	28	20
Factory Default:	20 %		20

This function is used to protect motor from running alone for a long time by changing operation to other motor.

Auto Change is accomplished when the following conditions are satisfied:

- 1) The time set in APP-27 is over.
- 2) The actual value of controlling amount is less than the value set in APP-28.
- 3) Only one motor is running.

When above three conditions are met, the inverter stops the running motor, and changes motor to run by the order set in APP-26. and then continues operation according to new order.

If Auto Change Level (APP-28) is set to '0', the function is initiated only when the motor is in Stop or Sleep state. The

count time for Auto Change is depend on Auto Change Mode (APP-26). In mode '0', inverter starts counting only when auxiliary motor is running. In mode '1' or '2', inverter starts counting when any motor is running including main motor.

APP-29: Inter-Lock Selection

APP▶Inter-lock 29 --- No ---	29	0
Factory Default: No		0

By setting this code to 'Yes', the multi-function input terminals (P1 ~ P4) are used as auxiliary motor operating condition of RLY1, RLY2, RLY3, and AUX. The multi-function input terminal should be turned on to run the corresponding auxiliary motor. If running with any multi-function input terminal open with this function, the inverter starts motors except the corresponding motor. If multi-function input happens to be turned off during motor running, the inverter stops all running motors and restarts running with only normal motors except the subject motor. By setting this parameter to 'Yes', the multi-function input terminals (P1~P4) are set to 'Interlock1' through 'Interlock4' automatically.

Note: P1 through P4 cannot be used for other purpose if this code is set to 'Yes'.

Related Functions: I/O-12 to I/O-14 [Multi-Function Input]
EXT-02 to EXT-04 [Multi-Function Input]

APP-30: Actual Value Display

APP▶Actual Value 30 0.00 Hz	30	0.00
Factory Default: 0.00 Hz		0.00

This code displays the value using on PID controller in frequency.

APP-31: Actual Value Display in Percentage

APP▶Actual Perc 31 0 %	31	0
Factory Default: 0 %		0

This code displays the value using on PID controller in percentage.

APP-32: Draw Mode Selection

APP▶Draw Mode 32 None	32	0
Factory Default: None		0

This code sets the signal input to use for Draw operation. The main reference frequency is set in DRV-04. This parameter should be set to a signal that is not selected in DRV-04.

APP-33: Draw Size Setting

APP▶Draw Perc 33 100 %	33	100
Factory Default: 100 %		100

This code sets the frequency bandwidth during Draw operation. For example, when Reference Frequency (DRV-00) is set to '30Hz', Draw Mode (APP-32) to 'V1_Draw' and Draw Size (APP-33) to '10%', the frequency difference during Draw operation is between 27 Hz and 33Hz. The following figure shows the block diagram for Draw and Override operation.

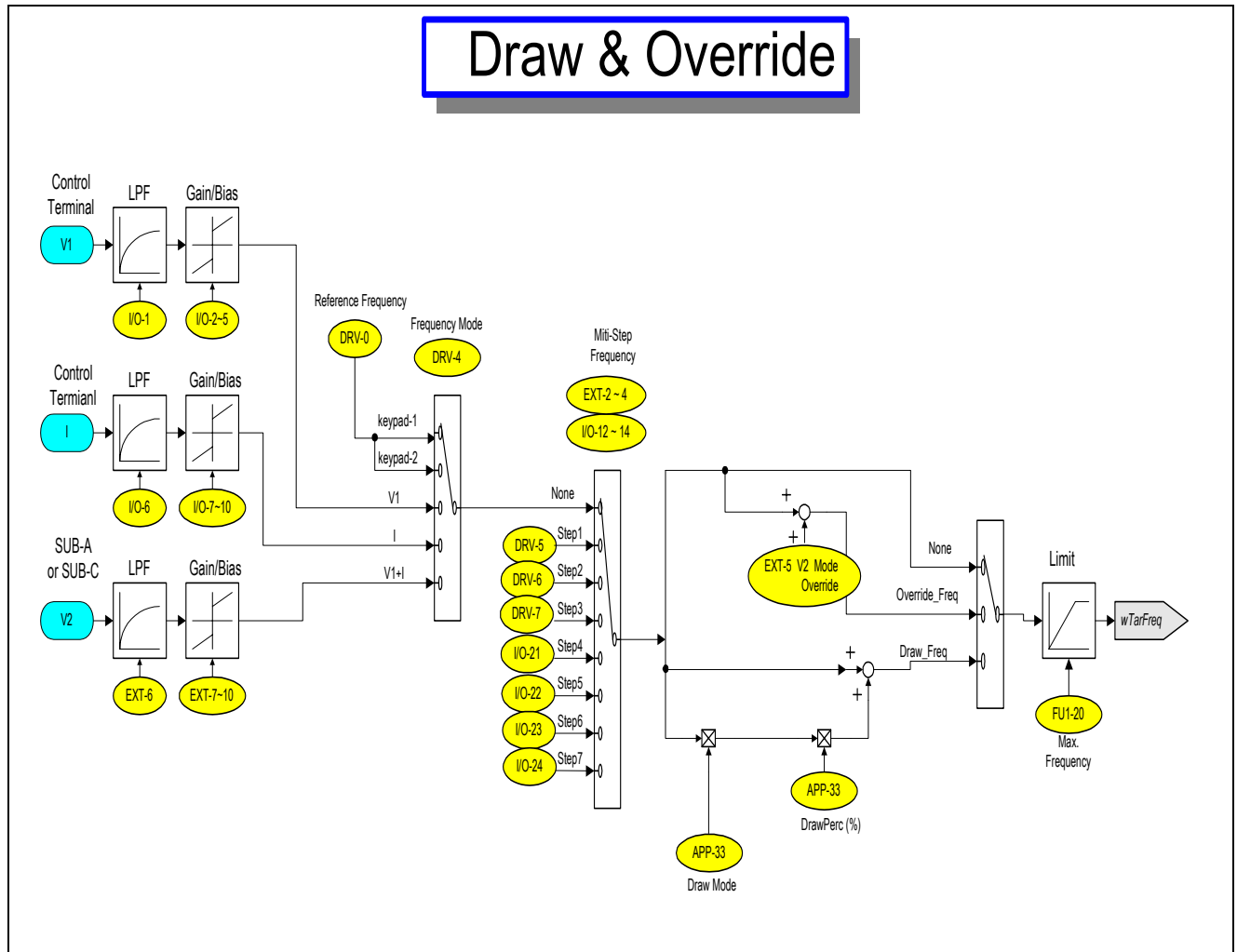

CHAPTER 7 - OPTIONS

The AActionMaster series inverter provides many options for various applications. See the following option table and select the proper options according to your application.

Option	Name	Description		
Internal Installation	Sub Boards	Sub-A Board (Extended I/O)	<input type="checkbox"/> Extended I/O Module <input type="checkbox"/> Three Multi-Function Inputs (P4, P5, P6) <input type="checkbox"/> Three Multi-Function Outputs (Q1, Q2, Q3) <input type="checkbox"/> Auxiliary Analog Frequency Reference (V2) <input type="checkbox"/> LM (Load Meter) Output (0 ~ 10V)	
		Sub-B Board (Speed Feedback)	<input type="checkbox"/> Encoder Pulse Input – Speed Feedback (AOC, BOC / A+, A-, B+, B-) <input type="checkbox"/> Encoder Pulse Output (FBA, FBB) <input type="checkbox"/> Vector control (PG operation) and reference freq via pulse input	
		Sub-C Board (Extended I/O)	<input type="checkbox"/> Extended I/O Module <input type="checkbox"/> Three Multi-Function Inputs (P4, P5, P6) <input type="checkbox"/> One Multi-Function Outputs (Q1) <input type="checkbox"/> Isolated Auxiliary Analog Frequency Reference (V2) <input type="checkbox"/> Two Isolated Analog Meter Output (AM1, AM2)	
		Sub-D Board (Extended I/O, Speed Feedback)	<input type="checkbox"/> Extended I/O Module <input type="checkbox"/> Three Multi-Function Inputs (P4, P5, P6) <input type="checkbox"/> Two Multi-Function Outputs (Q1, Q2) <input type="checkbox"/> Auxiliary Analog Frequency Reference (V2) <input type="checkbox"/> Encoder Pulse Input – Speed Feedback (AOC, BOC / A+, A-, B+, B-) <input type="checkbox"/> Encoder Pulse Output (FBA, FBB)	
	Option Boards	Device Net	<input type="checkbox"/> Embedded DeviceNet protocol <input type="checkbox"/> CAN Controller <input type="checkbox"/> Inverter Connection: Max. 64 <input type="checkbox"/> Input Voltage: DC 11 ~ 25V <input type="checkbox"/> Baud Rate: 125, 250, 500k bps <input type="checkbox"/> CSMA/CD-NBA Method	
		PLC Communication (F-Net)	<input type="checkbox"/> Connection with Fnet Communication Module for GLOFA PLC <input type="checkbox"/> Inverter Connection: Max. 64 <input type="checkbox"/> Baud Rate: 1M bps <input type="checkbox"/> Token Method	
		RS-485	<input type="checkbox"/> RS-485 Communication <input type="checkbox"/> Inverter Connection: Max. 32 <input type="checkbox"/> Baud Rate: Max. 19200 bps	
		Profi-Bus	<input type="checkbox"/> Connection to ProfiBus Network <input type="checkbox"/> Device Type: Profibus DP Slave <input type="checkbox"/> Inverter Connection: Max. 64 <input type="checkbox"/> Baud Rate: Max. 12M bps	
	External Installation	Keypad	LCD	<input type="checkbox"/> 32-Character Display <input type="checkbox"/> Download and Upload from the Keypad
			7-Segment	<input type="checkbox"/> Six Digit 7-Segment Display

Chapter 7 - Options

Option	Name	Description
Remote Cable	Remote Cable	<input type="checkbox"/> 2m, 3m, 5m long keypad cables for separate keypad installation
Dynamic Braking	DB Resistor	<input type="checkbox"/> Enables Inverter to decelerate rapidly
	DB Unit	<input type="checkbox"/> DB units are provided as an option for 15 ~ 30 HP inverters

Note) Refer to option manual for more details.

The following table shows the Sub-Board Selection Guide According To Functions.

Code	Function Description	Sub-Board Type			
		SUB-A Board	SUB-B Board	SUB-C Board	SUB-D Board
EXT-02	Multi-Function Input Terminal 'P4'	√		√	√
EXT-03	Multi-Function Input Terminal 'P5'	√		√	√
EXT-04	Multi-Function Input Terminal 'P6'	√		√	√
EXT-05	V2 Mode Selection	√		√	√
EXT-06	Filtering Time Constant for V2 Input Signal	√		√	√
EXT-07	V2 Input Minimum Voltage	√		√	√
EXT-08	Frequency Corresponding to V2 Input Minimum Voltage	√		√	√
EXT-09	V2 Input Maximum Voltage	√		√	√
EXT-10	Frequency Corresponding to V2 Input Maximum Voltage	√		√	√
EXT-14	Usage for Pulse Input Signal		√		√
EXT-15	Pulse Input Signal Selection		√		√
EXT-16	Encoder Pulse Selection		√		√
EXT-17	Filtering Time Constant for Pulse Input Signal		√		√
EXT-18	Pulse Input Minimum Frequency		√		√
EXT-19	Frequency Output corresponding to Pulse Input Minimum Frequency		√		√
EXT-20	Pulse Input Maximum Frequency		√		√
EXT-21	Frequency Output corresponding to Pulse Input Maximum Frequency		√		√
EXT-22	P-Gain for PG Option		√		√
EXT-23	I-Gain for PG Option		√		√
EXT-24	Slip Frequency for PG Option		√		√
EXT-25	P-Gain for (Sensored) Vector_SPD				√
EXT-26	I-Gain for (Sensored) Vector_SPD				√
EXT-27	Forward Torque Limit				√
EXT-28	Reverse Torque Limit				√
EXT-30	Multi-function Output Terminal 'Q1'	√		√	√
EXT-31	Multi-function Output Terminal 'Q2'	√			√
EXT-32	Multi-function Output Terminal 'Q3'	√			
EXT-34	LM (Load Meter) Output Selection	√			
EXT-35	LM Output Adjustment	√			
EXT-40	AM1 (Analog Meter 1) Output Selection			√	
EXT-41	AM1 Output Adjustment			√	
EXT-42	AM2 (Analog Meter 2) Output Selection			√	
EXT-43	AM2 Output Adjustment			√	

7.1 Sub-A board

7.1.1 Board configuration

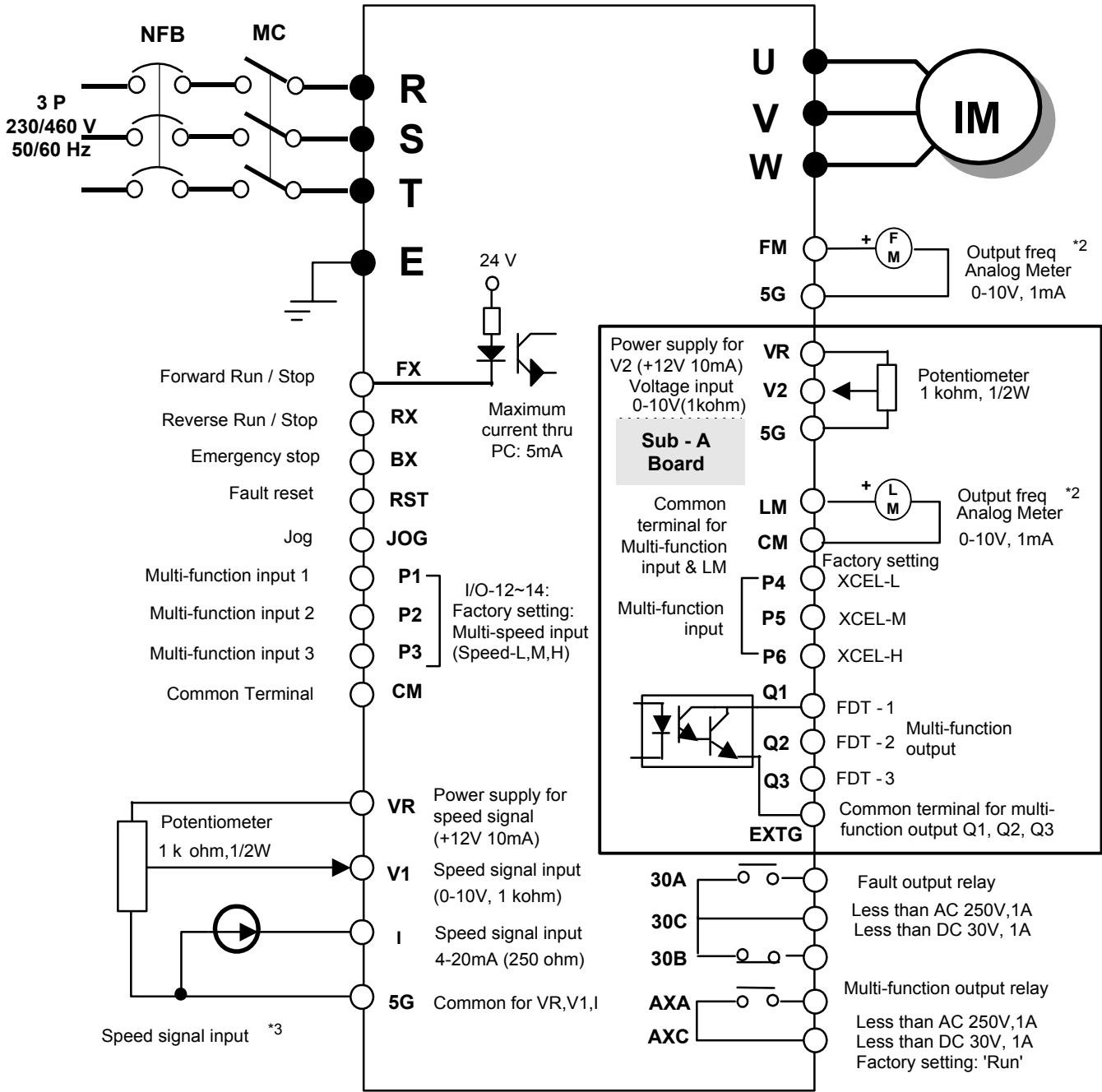

- Note) 1. ● : Main circuit ○ : Control circuit
 2. Output voltage is adjustable up to 12V.
 3. Three types of External speed signal input available.
 (V, I, V+I, Refer to Parameter list and description for more details)

7.1.2 Terminal Configuration

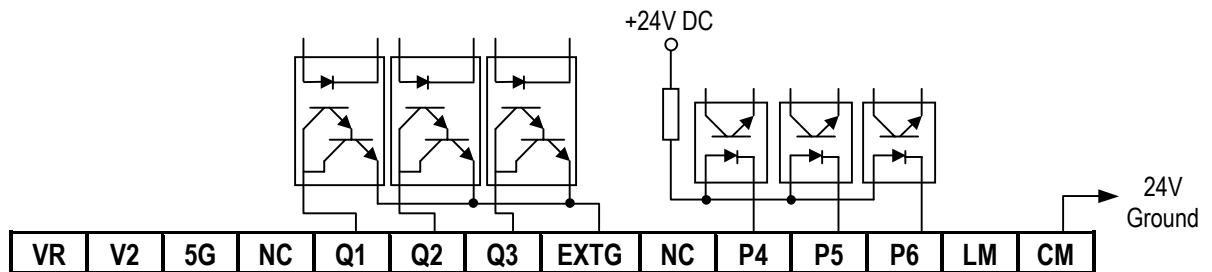

7.1.3 Terminal Description

Section		Terminal	Name	Description
Input	Contact Input	P4, P5, P6	Multi-Function Input	Used as the extended function of P1, P2, P3 (I/O-12 ~ I/O-14)
		CM	Common Terminal	Common terminal for P4, P5, P6
	Analog Frequency Reference	VR	Power Supply for V2	DC voltage output terminal for V2 (+12V, 10mA)
		V2	Analog Voltage Input	Analog voltage input terminal for frequency reference or override.
		5G	Common Terminal	Common terminal for VR and V2
Output	+15V Pulse Output	LM	Load Meter	Used to monitor one of Output Frequency, Output Current, Output Voltage, DC link Voltage. (+15V Pulse output, Average voltage: 0 ~ 10V DC)
		CM	Common Terminal	Common terminal for LM
	Open Collector Output	Q1, Q2, Q3	Multi-Function Output (Open-Collector Output)	Used as the extended function of AXA, AXC (I/O-44)
		EXTG	External Common Terminal	Common terminal for Q1, Q2, Q3
		NC	Not Used	

7.1.4 Parameters of Sub-A Board

Code	Parameter Description	Code	Parameter Description
EXT-01	Sub Board Type Display	EXT-09	Analog Voltage Input Signal (V2) Adjustment
EXT-02	Multi-Function Input Terminal (P4, P4, P6) Define	EXT-10	
EXT-03		Multi-Function Output Terminal (Q1, Q2, Q3) Define	EXT-30
EXT-04	EXT-31		
EXT-05	V2 Mode Selection		EXT-32
EXT-06	Filtering Time Constant for V2 Input Signal	EXT-34	LM Output Adjustment
EXT-07	Analog Voltage Input Signal (V2) Adjustment	EXT-35	
EXT-08			

7.2 Sub-B Board

7.2.1 Board configuration

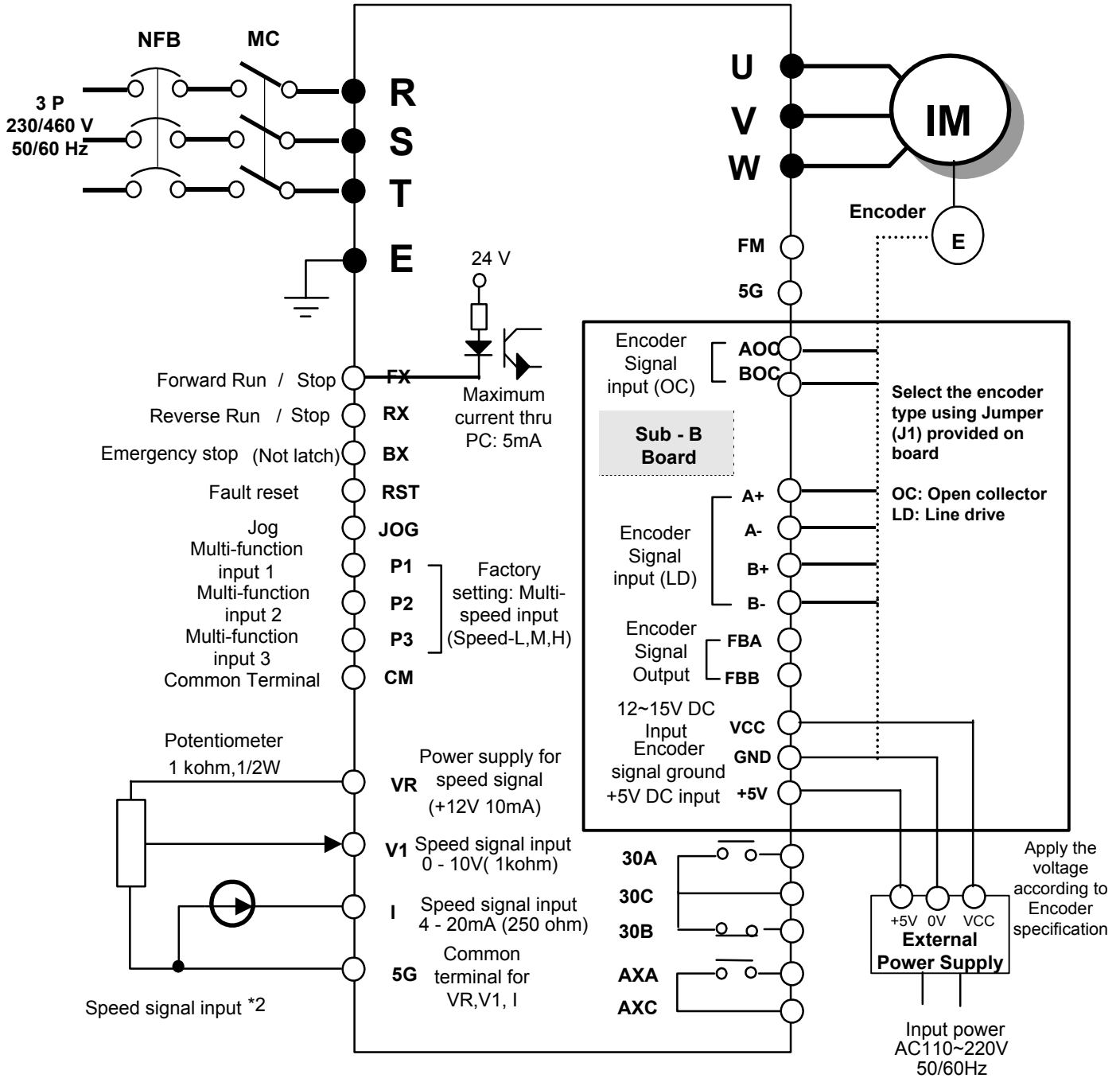

- Note) 1. ● : Main circuit ○ : Control circuit
 2. Three types of External speed signal input available
 (V, I, V+I, Refer to Parameter list and description for more details)

7.2.2 Terminal Configuration (total 14 pins)

AOC	BOC	A+	A-	B+	B-	FBA	FBB	GND	GND	+5V	+5V	VCC	VCC
-----	-----	----	----	----	----	-----	-----	-----	-----	-----	-----	-----	-----

7.2.3 Terminal Description

Section		Terminal	Name	Description
Encoder Signal Input	Open Collector Type	AOC	A Pulse Input Terminal	Connects A signal of Open Collector type encoder
		BOC	B Pulse Input Terminal	Connects B signal of Open Collector type encoder
	Line Drive Type	A+	A+ Pulse Input Terminal	Connects A+ signal of Line Drive type encoder
		A-	A- Pulse Input Terminal	Connects A- signal of Line Drive type encoder
		B+	B+ Pulse Input Terminal	Connects B+ signal of Line Drive type encoder
		B-	B- Pulse Input Terminal	Connects B- signal of Line Drive type encoder
Signal Output	Encoder Signal Output	FBA	Encoder A Pulse Output	Outputs A signal received from the encoder
		FBB	Encoder B Pulse Output	Outputs B signal received from the encoder
Power Supply Input		+5V	+5V DC Input Terminal (For Line Drive type)	Provides +5V DC power output to encoder (5V DC, Minimum 0.5A)
		VCC	+12 to 15V DC Input/output Terminal from External Power Supply to Encoder (For Open collector type)	This is the encoder supply voltage. Supply proper voltage according to the encoder specification. (+12 to 15V DC, Minimum 0.5A)
		GND	Ground Terminal	Ground for Power supply and encoder signal

7.2.4 Parameters of Sub-B Board

Code	Parameter Description	Code	Parameter Description
EXT-01	Sub Board Type Display	EXT-21	Pulse Input Signal Adjustment
EXT-14	Usage for Pulse Input Signal	EXT-22	P-Gain
EXT-15	Pulse Input Signal Selection	EXT-23	I-Gain
EXT-16	Encoder Pulse Number	EXT-24	Slip Frequency
EXT-17	Filtering Time Constant	EXT-25	P-Gain for (Sensored) Vector_SPD
EXT-18	Pulse Input Signal Adjustment	EXT-26	I-Gain for (Sensored) Vector_SPD
EXT-19		EXT-27	Forward Torque Limit
EXT-20		EXT-28	Reverse Torque Limit

1. Sub-B board with Line Drive type encoder

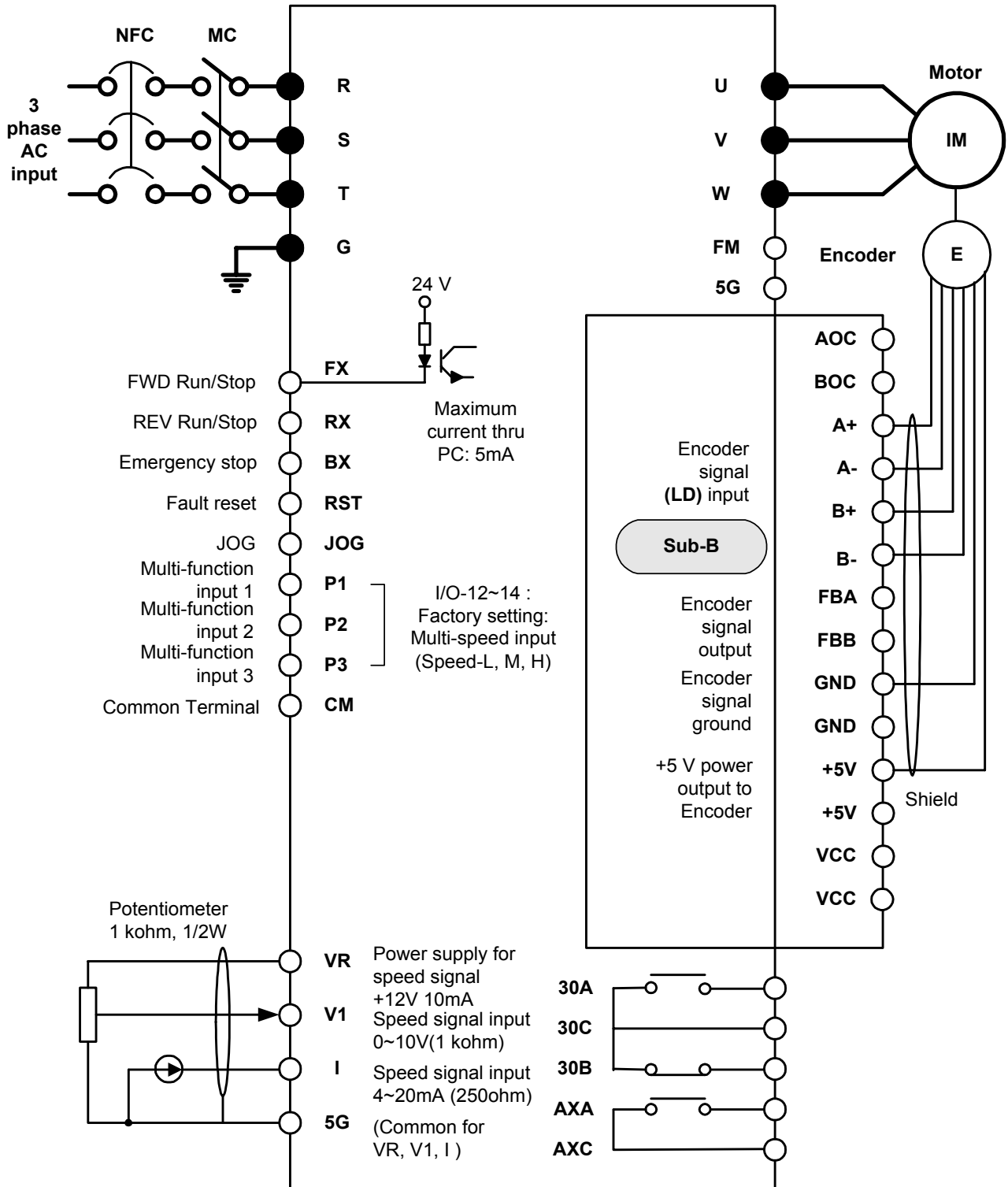

Note) 1. ● : Main circuit, ○ : Control circuit.
 2. External speed signal: V1, I, V1+I (Refer to Parameter list)

2. Sub-B board with Open collector type encoder

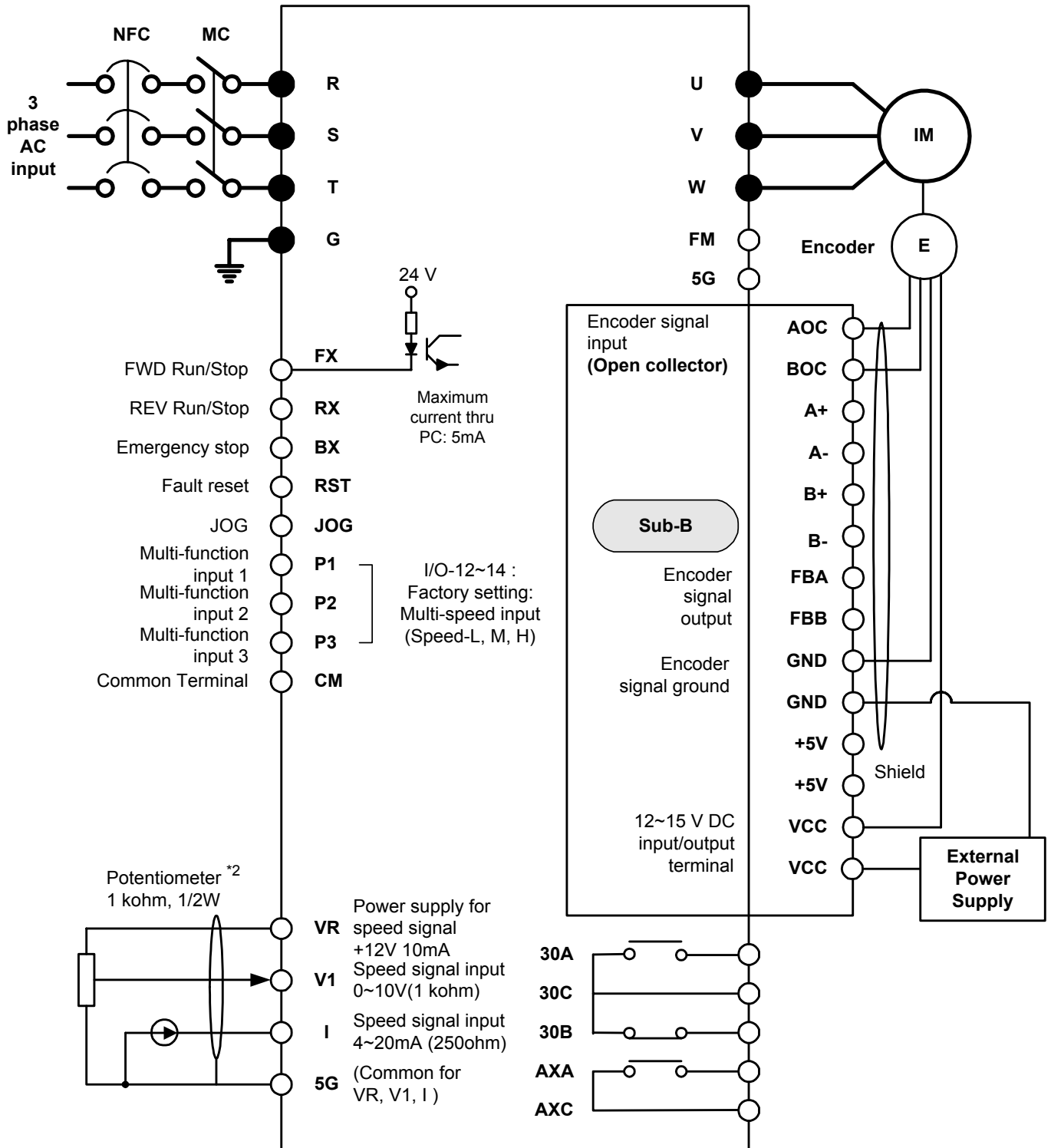

7.3 Sub-C Board (Isolated)

7.3.1 Board Configuration

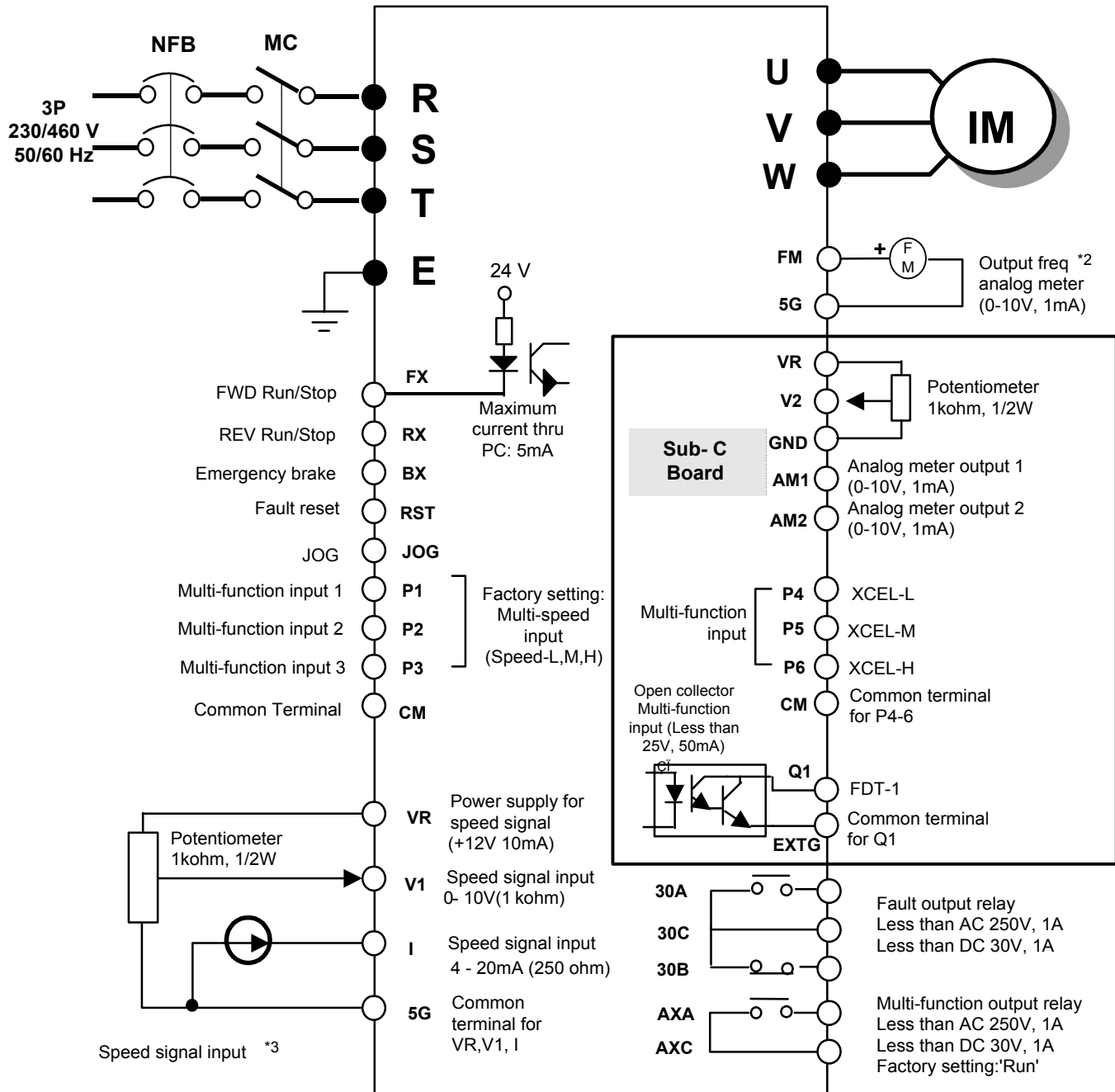

- Note) 1. ● : Main circuit ○ : Control circuit
 2. Output voltage is adjustable up to 12V
 3. Three types of External speed signal input available (V, I, V+I, Refer to Parameter list and description for more details)

7.3.2 Terminal Configuration

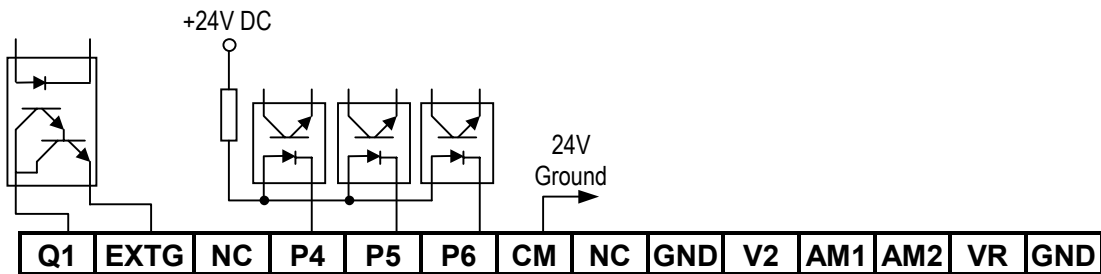

7.3.3 Terminal Description

Section		Terminal	Name	Description
Input	Contact Input	P4, P5, P6	Multi-Function Input	Used as the extended function of P1, P2, P3 (I/O-12 ~ I/O-14).
		CM	Common Terminal	Common terminal for P4, P5, P6
	Analog Frequency Reference	VR	Power supply for V2	DC voltage output terminal for V2 (+12V, 10mA)
		V2	Analog Voltage Input	Analog voltage or current input terminal for frequency reference or override. (0 ~ 10V DC, 4 ~ 20mA) Connecting jumper pin (J1) select current input.
		5G	Common Terminal	Common terminal for VR and V2
Output	Analog Voltage	AM1	Analog Meter 1	Used to monitor one of Output Frequency, Output Current, Output Voltage, DC link Voltage (0 ~ 10V DC analog output, 1mA)
		AM2	Analog Meter 2	
		GND	Common Terminal	Common terminal for LM
	Open Collector Output	Q1	Multi-function Output	Used as the extended function of AXA, AXC (I/O-44)
		EXTG	External Common Terminal	Common terminal for Q1
		NC	Not Used	

7.3.4 Parameters of Sub-C Board

Code	Parameter Description	Code	Parameter Description
EXT-01	Sub Board Type Display	EXT-09	Analog Voltage Input Signal (V2) Adjustment
EXT-02	Multi-Function Input Terminal (P4, P5, P6) define	EXT-10	
EXT-03		EXT-30	Multi-function Output Terminal (Q1) define
EXT-04		AM1, AM2 Adjustment	EXT-40
EXT-05	EXT-41		
EXT-06	EXT-43		
EXT-07	EXT-43		
EXT-08	Analog Voltage Input Signal (V2) Adjustment		

7.4 Sub-D Board

7.4.1 Board Configuration

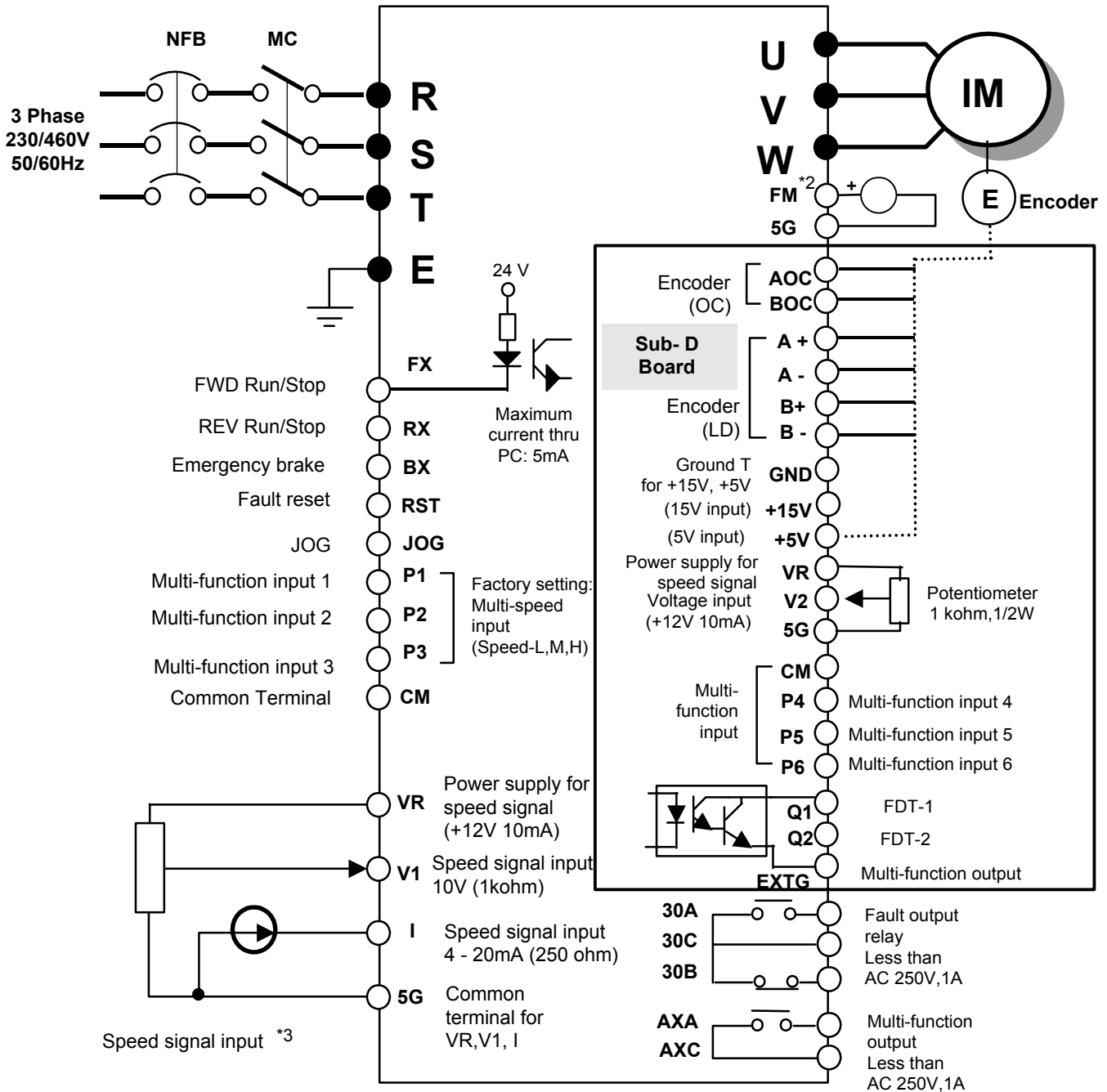

- Note) 1. ● : Main circuit ○ : Control circuit
 2. Output voltage is adjustable up to 12V
 3. Three types of External speed signal input available (V, I, V+I, Refer to Parameter list and description for more details)

7.4.2 Parameters of Sub-D board

Sub-D board comprises of Multi-function input P4, P5, P6, Multi-function output Q1, Q2, input/output terminal for Auxiliary analog frequency V2, and Encoder interface to receive pulse encoder input.

Encoder Pulse function

Code	Description	LCD display
EXT-01	Sub Board Type Display	Sub D
EXT-14	Usage for Pulse Input Signal	F mode
EXT-15	Pulse Input Signal Selection	F pulse set
EXT-16	Encoder Pulse Selection	F pulse num
EXT-17	Filtering Time Constant for Pulse Input Signal	F filter
EXT-18	Pulse Input Minimum Frequency	F pulse x1
EXT-19	Frequency Output corresponding to Pulse Input Minimum Frequency	F freq y1
EXT-20	Pulse Input Maximum Frequency	F pulse x2
EXT-21	Frequency Output corresponding to Pulse Input Maximum Frequency	F freq y2
EXT-22	P-Gain for PG Option	PG P gain
EXT-23	I-Gain for PG Option	PG I gain
EXT-24	Slip Frequency for PG Option	PG slip freq
EXT-25	P-Gain for (Sensored) Vector_SPD	ASR P-Gain
EXT-26	I-Gain for (Sensored) Vector_SPD	ASR I-Gain
EXT-27	Forward Torque Limit	Trq + Limit
EXT-28	Reverse Torque Limit	Trq - Limit

Input/Output function

Code	Description	LCD display
EXT-01	Sub Board Type Display	Sub D
EXT-02	Multi-Function Input Terminal 'P4'	P4 define
EXT-03	Multi-Function Input Terminal 'P5'	P5 define
EXT-04	Multi-Function Input Terminal 'P6'	P6 define
EXT-05	V2 Mode Selection	V2 mode
EXT-06	Filtering Time Constant for V2 Input Signal	V2 filter
EXT-07	V2 Input Minimum Voltage	V2 volt x1
EXT-08	Frequency Corresponding to V2 Input Minimum Voltage	V2 freq y1
EXT-09	V2 Input Maximum Voltage	V2 volt x2
EXT-10	Frequency Corresponding to V2 Input Maximum Voltage	V2 freq y2
EXT-30	Multi-function Output Terminal 'Q1'	Q1 define
EXT-31	Multi-function Output Terminal 'Q2'	Q2 define

7.4.3 Terminals Configuration (10 pins + 14 pins)

Q1	Q2	EXTG	NC	P4	P5	P6	CM	NC	V2	VR	5G	NC	NC
----	----	------	----	----	----	----	----	----	----	----	----	----	----

7.4.4 Terminal Descriptions

Section		Terminal	Terminal name	Terminal description
Input	Contact Input	P4,P5,P6	Multi-Function Input	Used as the extended function of P1, P2, P3. (I/O-12 ~ I/O-14).
		CM	Common Terminal	Common terminal for P4, P5, P6
	Analog Frequency Reference	VR	Power supply for V2	DC voltage output terminal for V2 (+12V, 10mA)
		V2	Analog Voltage Input	Sets the frequency by applying DC 0~10V. Input resistor: 20 kΩ
		5G	Common Terminal	Common terminal for VR and V2
Output	+15V Pulse Output	LM	Load Meter	Used to monitor one of Output Frequency, Output Current, Output Voltage, DC link Voltage. Factory setting: Output frequency. Output voltage: 0~10V, Output current: 1mA Preset freq: 500Hz
		CM	Common Terminal	Common terminal for LM
	Open Collector Output	Q1,Q2	Multi-Function Output (Open-Collect Output)	Used as the extended function of AXA, AXC (I/O-44) Below DC 25V, 50mA
		EXTG	External Common Terminal	Common terminal for Q1, Q2.
		NC	-	Not used.

FG	GND	+5V	+15V	AOC	BOC	A+	A-	B+	B-
----	-----	-----	------	-----	-----	----	----	----	----

Section		Terminal	Terminal name	Terminal description
Encoder input signal	Open Collector	AOC	A Pulse Input Terminal	Connects A signal of Open Collector type encoder
		BOC	B Pulse Input Terminal	Connects B signal of Open Collector type encoder
	Line Drive	A+	A+ Pulse Input Terminal	Connects A+ signal of Line Drive type encoder
		A-	A- Pulse Input Terminal	Connects A- signal of Line Drive type encoder
		B+	B+ Pulse Input Terminal	Connects B+ signal of Line Drive type encoder
		B-	B- Pulse Input Terminal	Connects B- signal of Line Drive type encoder
Power supply	+5V	+5V DC Input Terminal	Provides +5V DC power output to encoder (5V DC, Minimum 0.5A)	
	+15V	+15V DC Input/Output Terminal	Provides 15V DC Input/output Terminal from External Power Supply to Encoder (For Open collector type)	
	GND	Common for Encoder Input/output	Common terminal connecting encoder input/output signal	
Grounding	FG	Ground Terminal	Used to connect shield of encoder signal	

7.5 Communication option boards

7.5.1 F-Net (Needed for Communcation with CMC GLOFA PLC)

Open network system protocol based on IEC/ISA FieldBus

✧ Specification

- Topology : Linear Bus Topology
- Band Method : Baseband
- Protocol : Fnet Protocol
- Media Access Method : Token
- Drive link : Fiber optics
- Number of nodes : up to 64 nodes/Bus
- Max. Data transmission size : 256byte
- Baud rate : 1Mbps
- Transmission distance : 750m Max.
- Error check : CRC-16
- Encoding method : Menchester Biphase-L
- Station : 0 – 63 (Setting via Keypad. Dip-swich not provided)

7.5.2 Device-Net (Field bus)

✧ Features

- Topology: Linear Bus Topology
- Band Method : Baseband
- Protocol : DeviceNet Protocol
- Media Access Method : CSMA/CD-NBA
- (Carrier Sense Multiple Access / Collision Detection – Nondestructive Bitwise Arbitration)
- Drive link : 5-wire Cable (Twisted Pair)
- Number of nodes: 64 nodes/Bus Max
- Max. Data transmission size : max 8 bytes(64bits)
- Data rates and Max. Cable length (thick) : 125kbps (500m/1640ft), 250kbps (250m/820ft), 500kbps (100m/328ft)

✧ Specification

- Device type : AC Drive
- Communication control method :
 - ① Explicit Peer to Peer Messaging
 - ② Master/Scanner (Predefined M/S Connection)
 - ③ I/O Slave Messaging : Polling Connection
- Baud rate: 125kbps, 250kbps, 500kbps
- Supply voltage : 11 - 25V
- Faulted Node Recovery
- Station: 0 – 63 (Setting via Keypad, Dip-swich not provided)
- Output Assembly Instance : 20, 21(100, 101 vendor specific)
- Input Assembly Instance : 70, 71(110, 111 vendor specific)
- Open Style Connector
- Interface : DPRAM
- Supports EDS files

* Refer to communication option manuals for details.

7.5.3 RS485 Communication

The serial interface supports operation, configuration and monitoring of inverter functions through RS485 connection.

- 1) Terminal block configuration



- 2) Terminal Description

Terminal Name	Description
T1,T2	Short the terminal to connect the termination resistor on board
S	SHEILD
G	Power grounding terminal for RS485
P	Connect the RS485 signal - High Signal input/output terminal for RS 485
N	Connect the RS485 signal - Low Reference terminal for RS 485

7.5.4 Remote cable

Ordering Number	Description
	Remote cable - 2m
	Remote cable - 3m
	Remote cable - 5m

7.5.5 Mounting the option boards

Connect the option board to Control board using Connector CN2. .

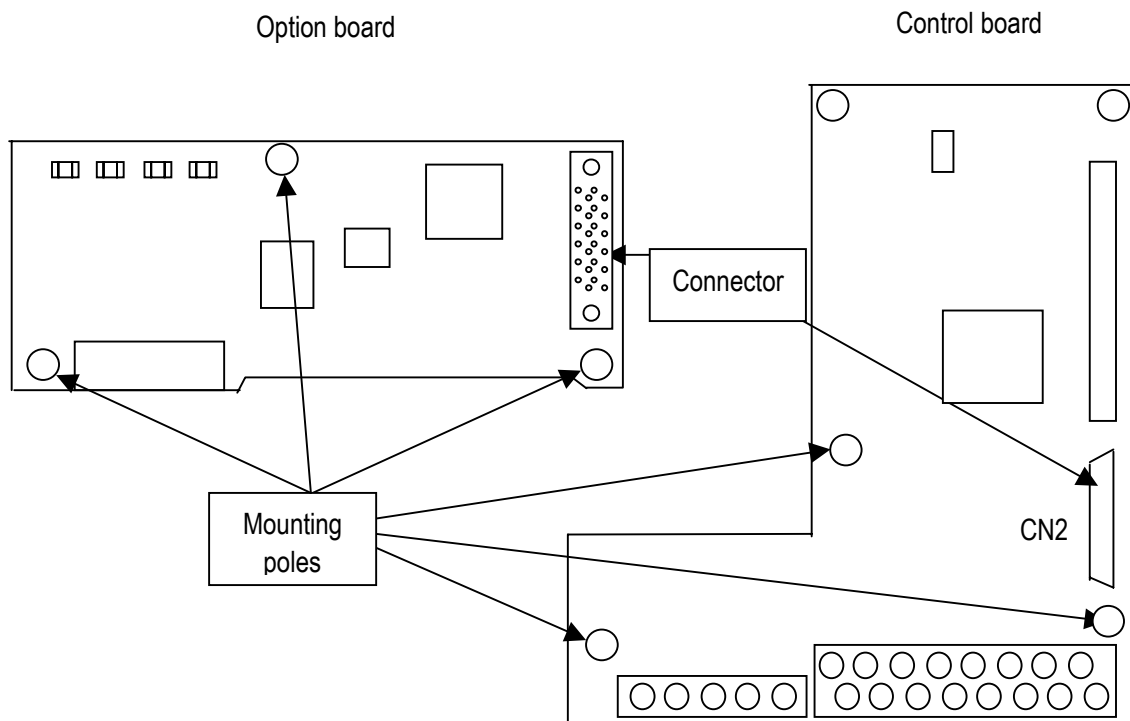

7.6 External options

7.6.1 Optional Keypads

SV-ACTIONMaster inverter has two different types of keypads for your convenience.

1) 7-Segment keypad (Weight: 110g, Unit: mm)

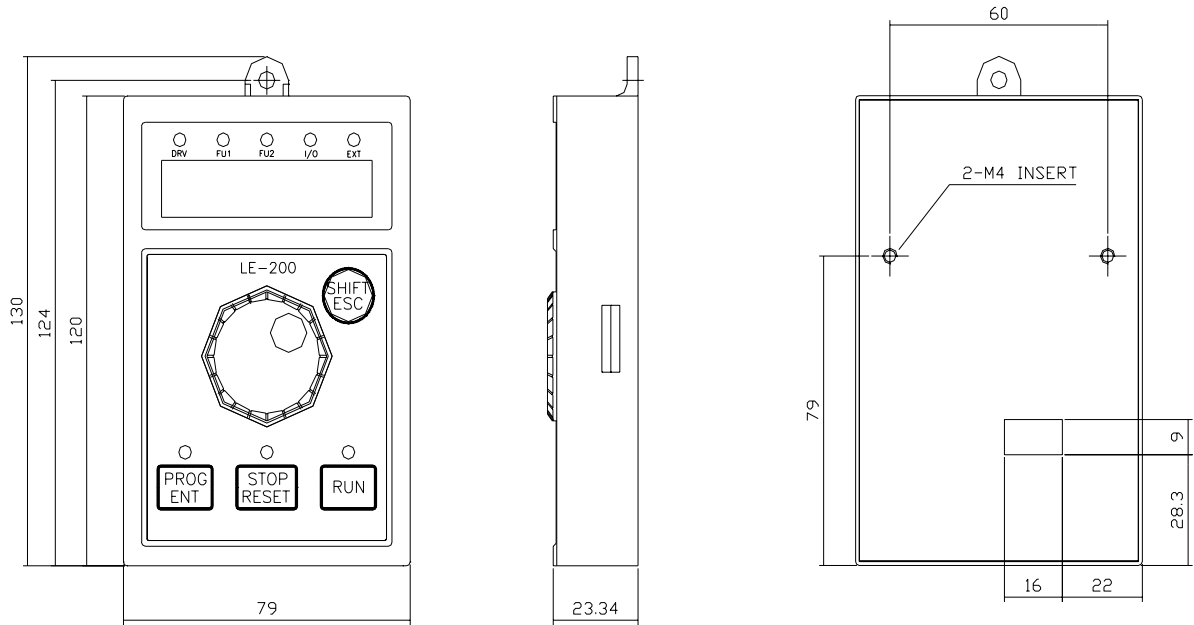

2) LCD Keypad (Weight: 140g, Unit: mm)

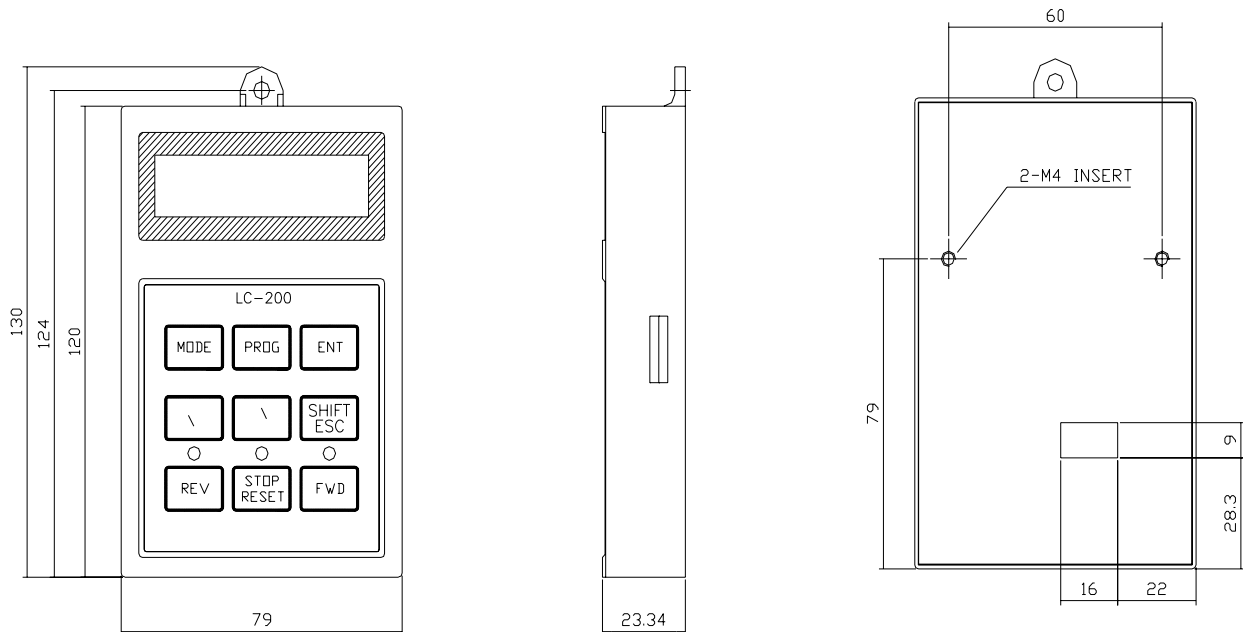

7.6.2 DB Resistors

1) Internal DB Resistor

SV-ACtionMaster inverters up to 3.7kW have built-in DB resistor on Power stack as factory installation. Installing the external DB resistor (Optional) kit is strongly recommended when the unit is used for continuous operation or motor rating is above 3.7kW.

Voltage	Applied motor capacity (kW/HP)	Operating rate (%ED/Continuous Braking Time)	Built in DB resistor (Braking Torque: 100%)
200V Class	0.75 / 1	3% / 5Sec	200 ohm, 100W
	1.5 / 2	3% / 5 Sec	100 ohm, 100W
	2.2 / 3	2% / 5 Sec	60 ohm, 100W
	3.7 / 5	2% / 5 Sec	40 ohm, 100W
400V Class	0.75 / 1	3% / 5 Sec	900 ohm, 100W
	1.5 / 2	3% / 5 Sec	450 ohm, 100W
	2.2 / 3	2% / 5 Sec	300 ohm, 100W
	3.7 / 5	2% / 5 Sec	200 ohm, 100W

2) DB Resistor (For External Installation, Optional)

DB transistor is integrated for ratings below 7.5kW. Install the external DB resistor if necessary. However, DB transistor is not provided for the ratings above 11kW, installing both external DB unit and DB resistor are required. See the following table for more details (ED: 5%, Continuous Braking Time:15 sec). If Enable duty (%ED) is increased to 10%, use the external DB resistor having twice Wattage rating.

	Applied motor capacity (kW / HP)	Operating rate (ED/Continuous Braking Time)	100 % Braking Torque			150% Braking Torque		
			[ohm]	[W]	Type	[ohm]	[W]	Type
200V	0.75 / 1	5% / 15 Sec	200	100	TYPE 1	150	150	TYPE 1
	1.5 / 2	5% / 15 Sec	100	200	TYPE 1	60	300	TYPE 1
	2.2 / 3	5% / 15 Sec	60	300	TYPE 1	50	400	TYPE 1
	3.7 / 5	5% / 15 Sec	40	500	TYPE 2	33	600	TYPE 2
	5.5 / 7.5	5% / 15 Sec	30	700	TYPE 3	20	800	TYPE 3
	7.5 / 10	5% / 15 Sec	20	1000	TYPE 3	15	1200	TYPE 3
	11 / 15	5% / 15 Sec	15	1400	TYPE 3	10	2400	TYPE 3
	15 / 20	5% / 15 Sec	11	2000	TYPE 3	8	2400	TYPE 3
	18.5 / 25	5% / 15 Sec	9	2400	TYPE 3	5	3600	TYPE 3
	22 / 30	5% / 15 Sec	8	2800	TYPE 3	5	3600	TYPE 3
400V	0.75 / 1	5% / 15 Sec	900	100	TYPE 1	600	150	TYPE 1
	1.5 / 2	5% / 15 Sec	450	200	TYPE 1	300	300	TYPE 1
	2.2 / 3	5% / 15 Sec	300	300	TYPE 1	200	400	TYPE 1

	Applied motor capacity (kW / HP)	Operating rate (ED/Continuous Braking Time)	100 % Braking Torque			150% Braking Torque		
			[ohm]	[W]	Type	[ohm]	[W]	Type
4 0 0 V	3.7 / 5	5% / 15 Sec	200	500	TYPE 2	130	600	TYPE 2
	5.5 / 7.5	5% / 15 Sec	120	700	TYPE 3	85	1000	TYPE 3
	7.5 / 10	5% / 15 Sec	90	1000	TYPE 3	60	1200	TYPE 3
	11 / 15	5% / 15 Sec	60	1400	TYPE 3	40	2000	TYPE 3
	15 / 20	5% / 15 Sec	45	2000	TYPE 3	30	2400	TYPE 3
	18.5 / 25	5% / 15 Sec	35	2400	TYPE 3	20	3600	TYPE 3
	22 / 30	5% / 15 Sec	30	2800	TYPE 3	20	3600	TYPE 3
	30/ 40							
	37/ 50							
	45/ 60							
	55/ 75							
	75/ 100							

3) DB Resistor Wiring

When wiring, connect the DB Resistor as SHORT as possible.

- DB resistor wiring for 1 – 5 HP Inverter

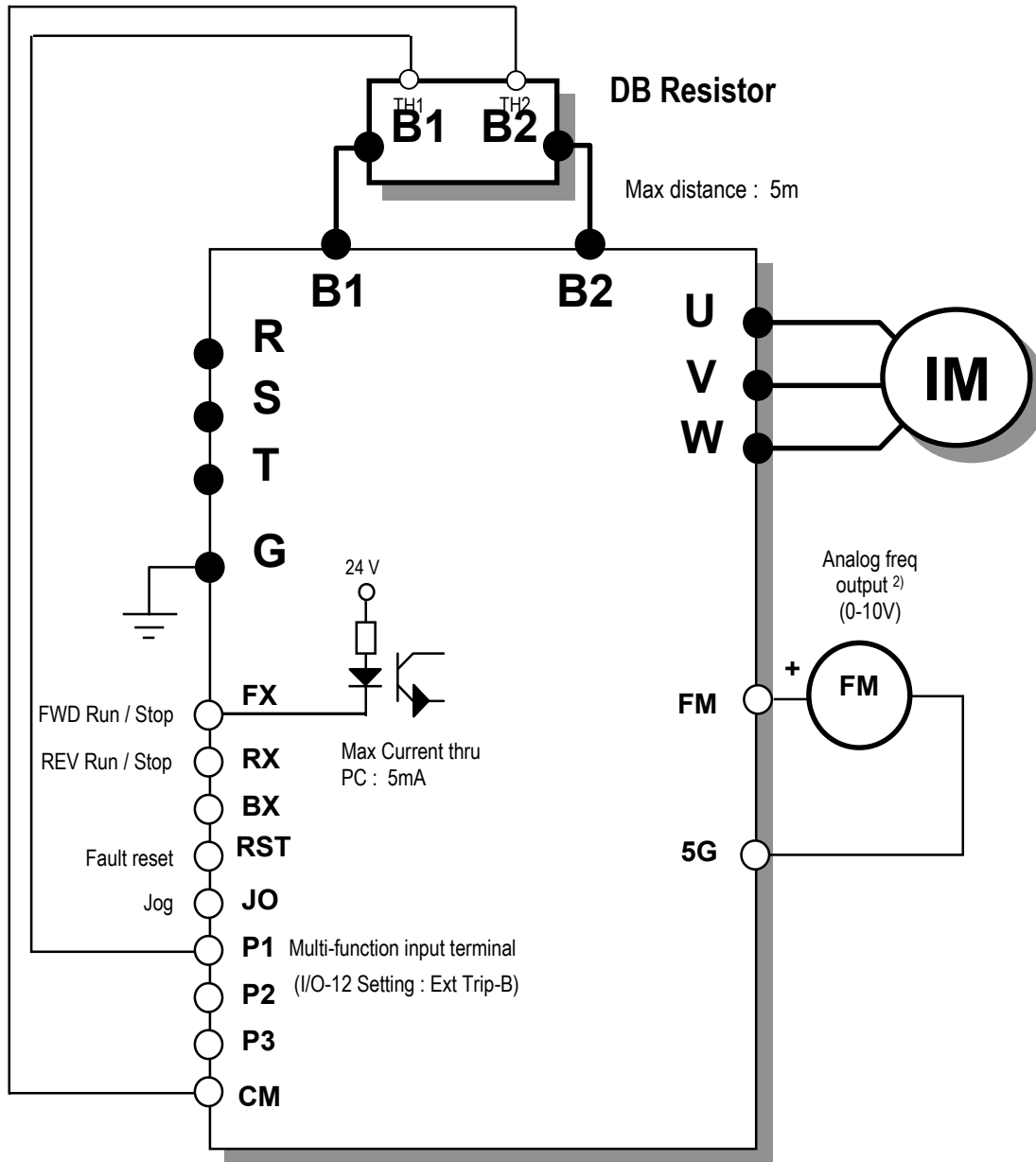

DB resistor terminal	Terminal description
B1, B2	Connect the DB Resistor to Inverter terminal B1,B2.
TH1, TH2	Thermal sensors provided with the DB resistor. P1 is ON (TH1-TH2 Shorted) at normal (ambient temp) and P1 is OFF (TH1-TH2 Open) at overheated status. Connect the thermal sensor to one of the multi-function input (P1, P2 or P3, I/O 12-14 setting: Ext Trip-B).

- DB resistor wiring for 7.5 - 10HP Inverter

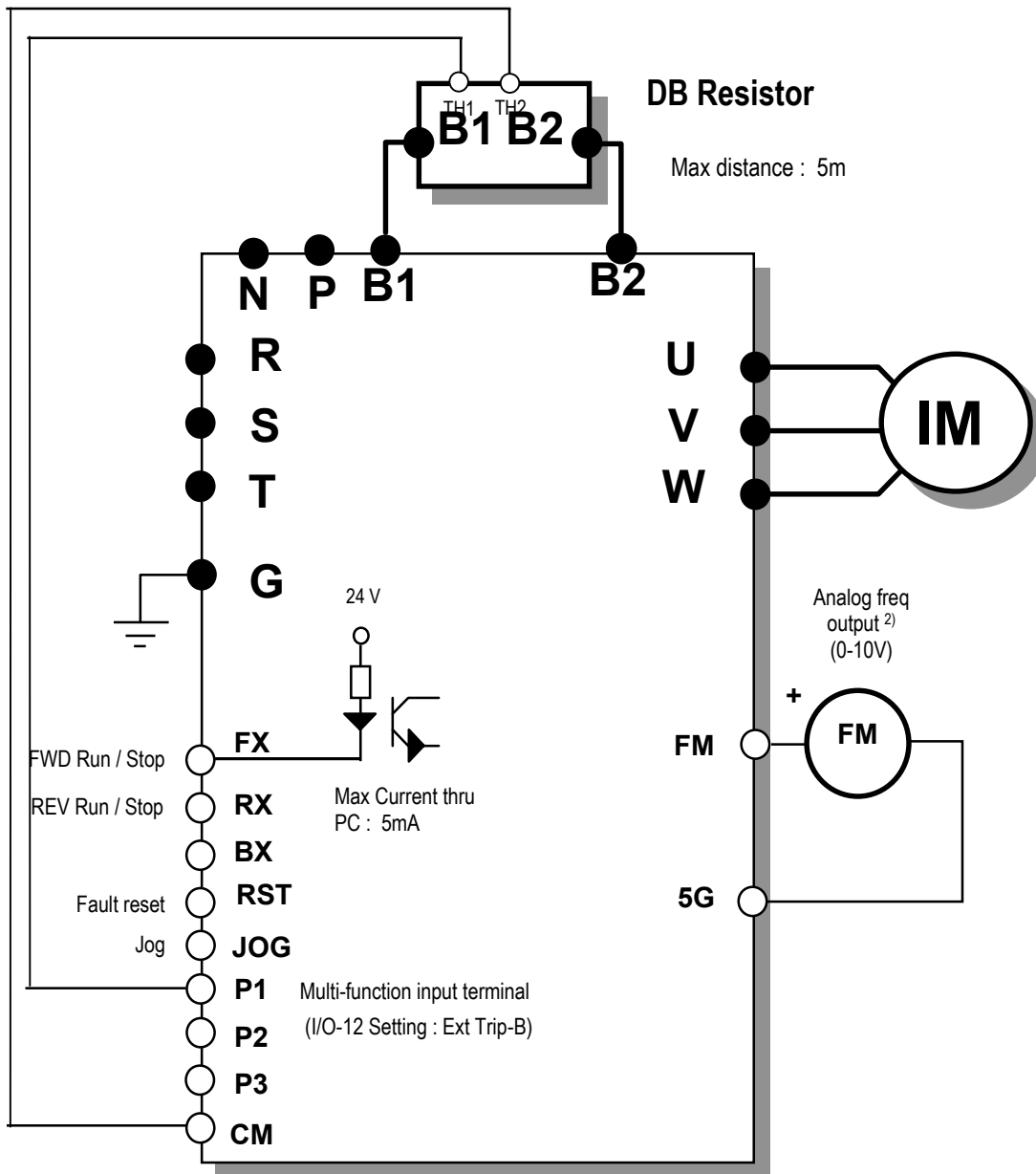

DB resistor terminal	Terminal description
B1, B2	Connect the DB Resistor to Inverter terminal B1,B2.
TH1, TH2	Thermal sensors provided with the DB resistor. P1 is ON (TH1-TH2 Shorted) at normal (ambient temp) and P1 is OFF (TH1-TH2 Open) at overheated status. Connect the thermal sensor to one of the multi-function input (P1, P2 or P3, I/O 12-14 setting: Ext Trip-B).

- DB Resistor/Unit wiring for 15-30 HP Inverter

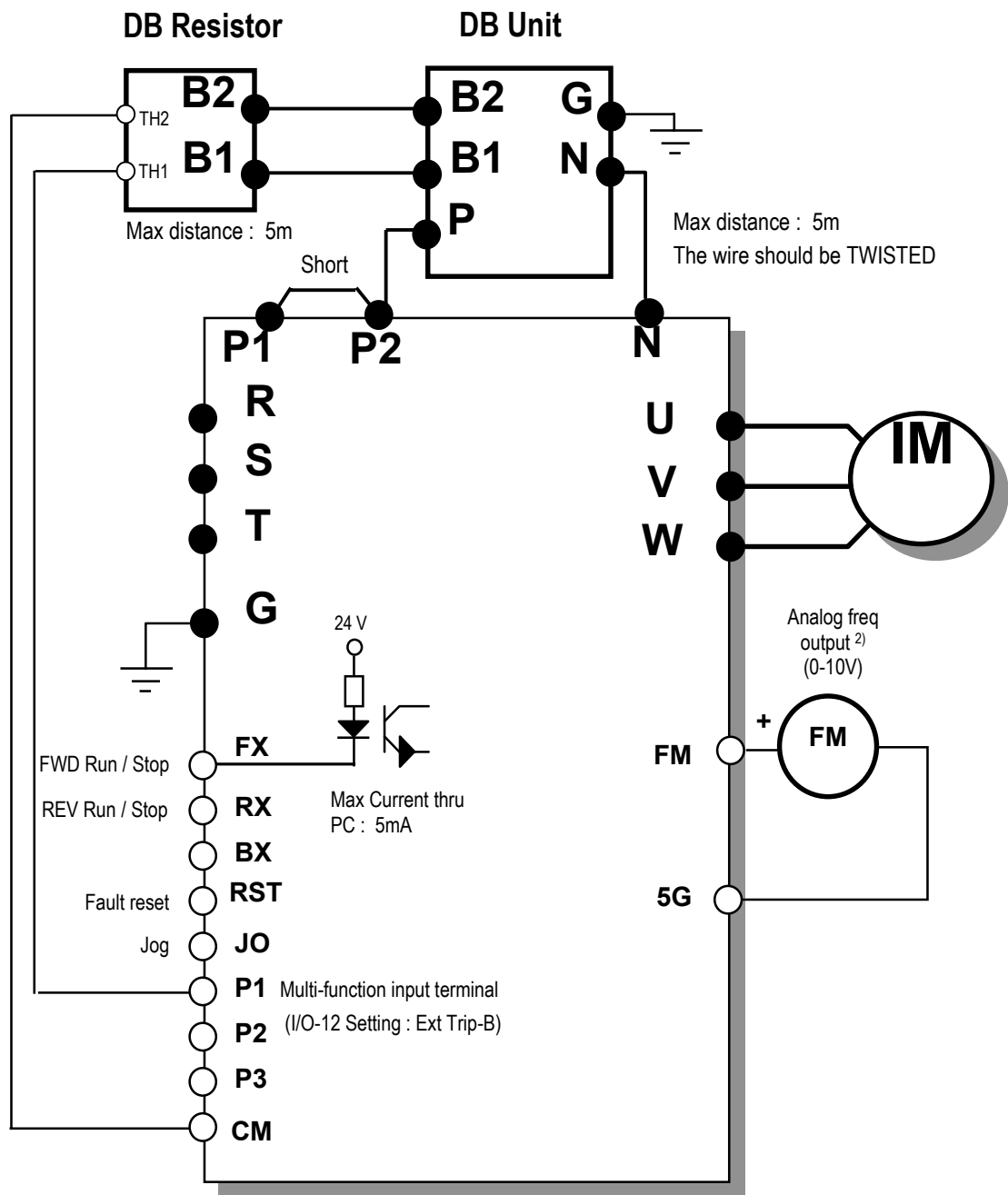

DB resistor terminal	Terminal description
B1, B2	Connect the DB Resistor to Inverter terminal B1,B2.
TH1, TH2	Thermal sensors provided with the DB resistor. P1 is ON (TH1-TH2 Shorted) at normal (ambient temp) and P1 is OFF (TH1-TH2 Open) at overheated status. Connect the thermal sensor to one of the multi-function input (P1, P2 or P3, I/O 12-14 setting: Ext Trip-B).

* For DBU, refer to 7.6.3 DB Unit.

4) DB Resistor Dimensions

DB Resistor	Inverter Model	Type	Dimensions [mm]					
			W	H	D	A	B	C
BR0400W150J	SV 008ACTIONMAST ER-2	1	64	412	40	-	400	6.3
BR0400W060J	SV 015ACTIONMAST ER-2	1	64	412	40	-	400	6.3
BR0400W050J	SV 022ACTIONMAST ER-2	1	64	412	40	-	400	6.3
BR0600W033J	SV 037ACTIONMAST ER-2	2	128	390	43	64	370	5
BR0800W020J	SV 055ACTIONMAST ER-2	3	220	345	93	140	330	7.8
BR1200W015J	SV 075ACTIONMAST ER-2	3	220	345	93	140	330	7.8
BR2400W010J	SV 110ACTIONMAST ER-2	3	220	445	93	140	430	7.8
BR2400W008J	SV 150ACTIONMAST ER-2	3	220	445	93	140	430	7.8
BR3600W005J	SV 185ACTIONMAST ER-2	3	220	445	165	140	430	7.8
BR3600W005J	SV 220ACTIONMAST ER-2	3	220	445	165	140	430	7.8
BR0400W600J	SV 008ACTIONMAST ER-4	1	64	412	40	-	400	6.3
BR0400W300J	SV 015ACTIONMAST ER-4	1	64	412	40	-	400	6.3
BR0400W200J	SV 022ACTIONMAST ER-4	1	64	412	40	-	400	6.3
BR0600W130J	SV 037ACTIONMAST ER-4	2	128	390	43	64	370	5

BR1000W085J	SV 055ACTIONMAST ER-4	3	220	345	93	140	330	7.8
BR1200W060J	SV 075ACTIONMAST ER-4	3	220	345	93	140	330	7.8
BR2000W040J	SV 110ACTIONMAST ER-4	3	220	445	93	140	430	7.8
BR2400W030J	SV 150ACTIONMAST ER-4	3	220	445	93	140	430	7.8
BR3600W020J	SV 185ACTIONMAST ER-4	3	220	445	165	140	430	7.8
BR3600W020J	SV 220ACTIONMAST ER-4	3	220	445	165	140	430	7.8
	SV 300ACTIONMAST ER-4							
	SV 370ACTIONMAST ER-4							
	SV 450ACTIONMAST ER-4							
	SV 550ACTIONMAST ER-4							
	SV 750ACTIONMAST ER-4							

* Type 1 (Max. 400 Watt)

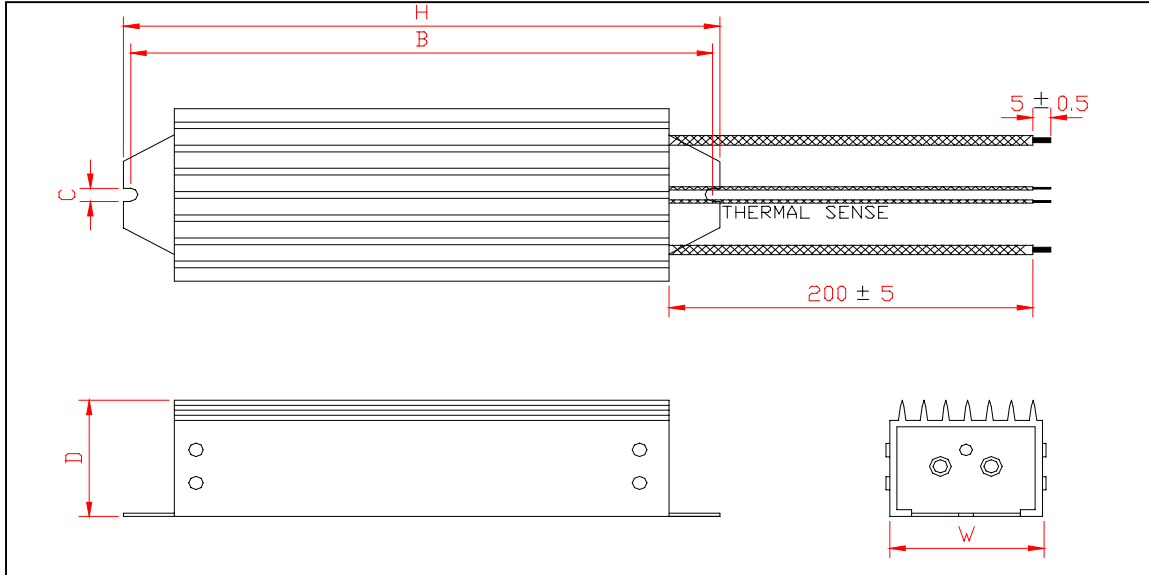

* Type 2 (Max. 600 Watt)

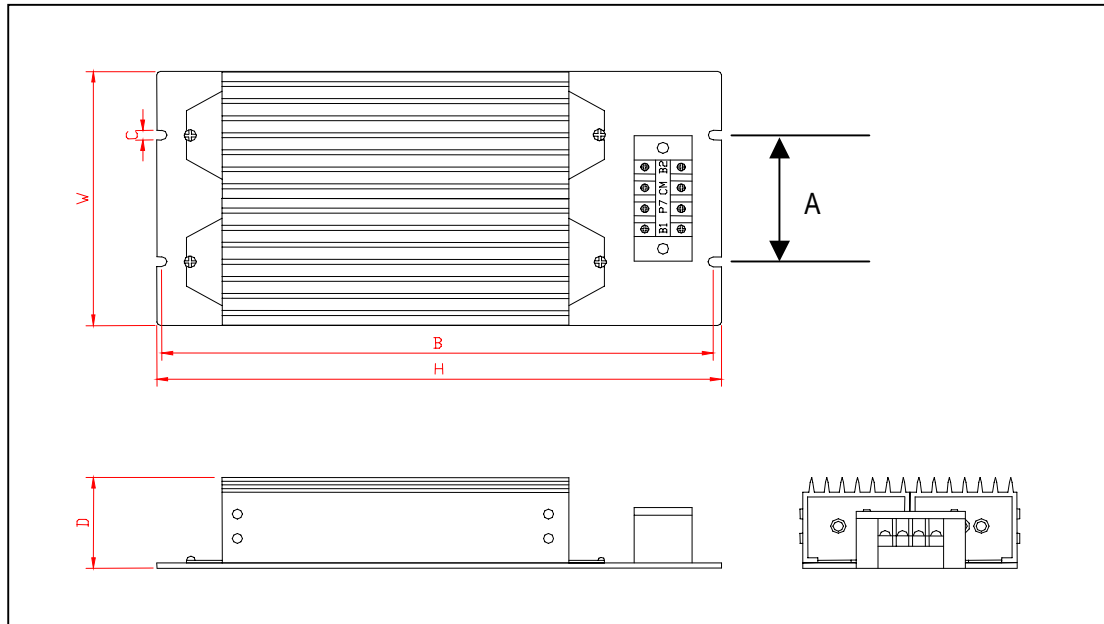

* Type 3

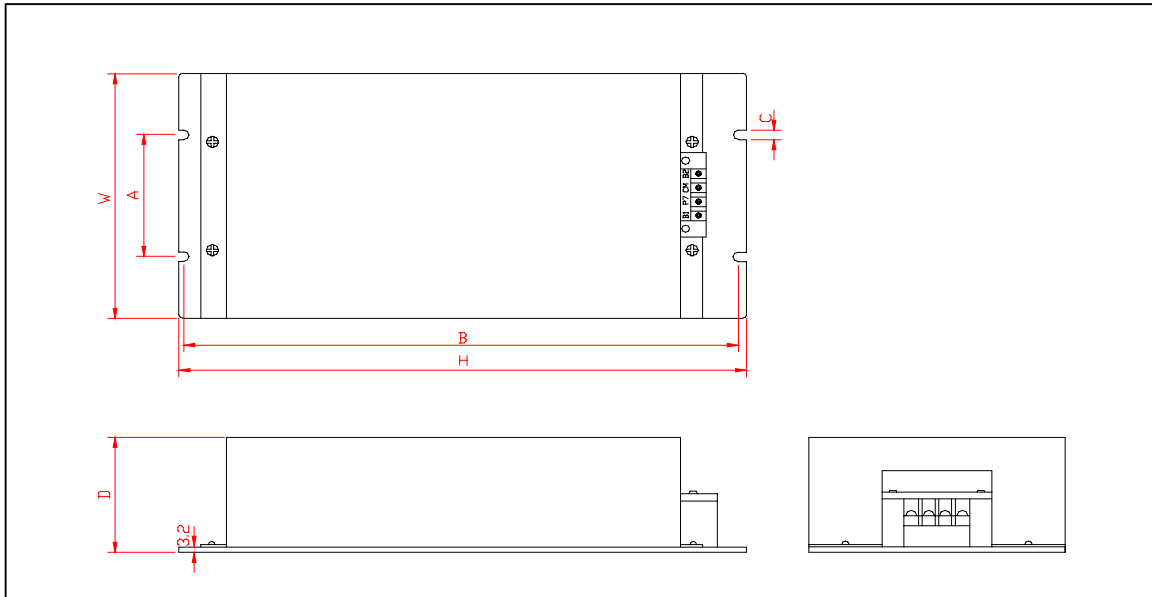

7.6.3 DB (Dynamic Brake) Unit

1) DBU models

Inverter	Applicable motor rating	DB Unit	Dimension
200V	11 ~ 15 kW	SV150DBU-2	See 4) Dimension
200V	18.5 ~ 22 kW	SV220DBU-2	
400V	11 ~ 15 kW	SV150DBU-4	
400V	18.5 ~ 22 kW	SV220DBU-4	
400V	30 ~ 37 kW	SV370DBU-4U	
400V	45 ~ 55 kW	SV550DBU-4U	
400V	75 kW	SV750DBU-4U	

2) Terminal configuration



Terminal	Description
G	Grounding terminal
B2	Connect it to DB Resistor terminal B2
B1	Connect it to DB Resistor terminal B1
N	Connect it to Inverter terminal N
P	Connect it to Inverter terminal P
CM	Common for Terminal OH
OH*	Overheat Trip Output Terminal (Open Collector output : 20mA, 27V DC)

4) Dimension

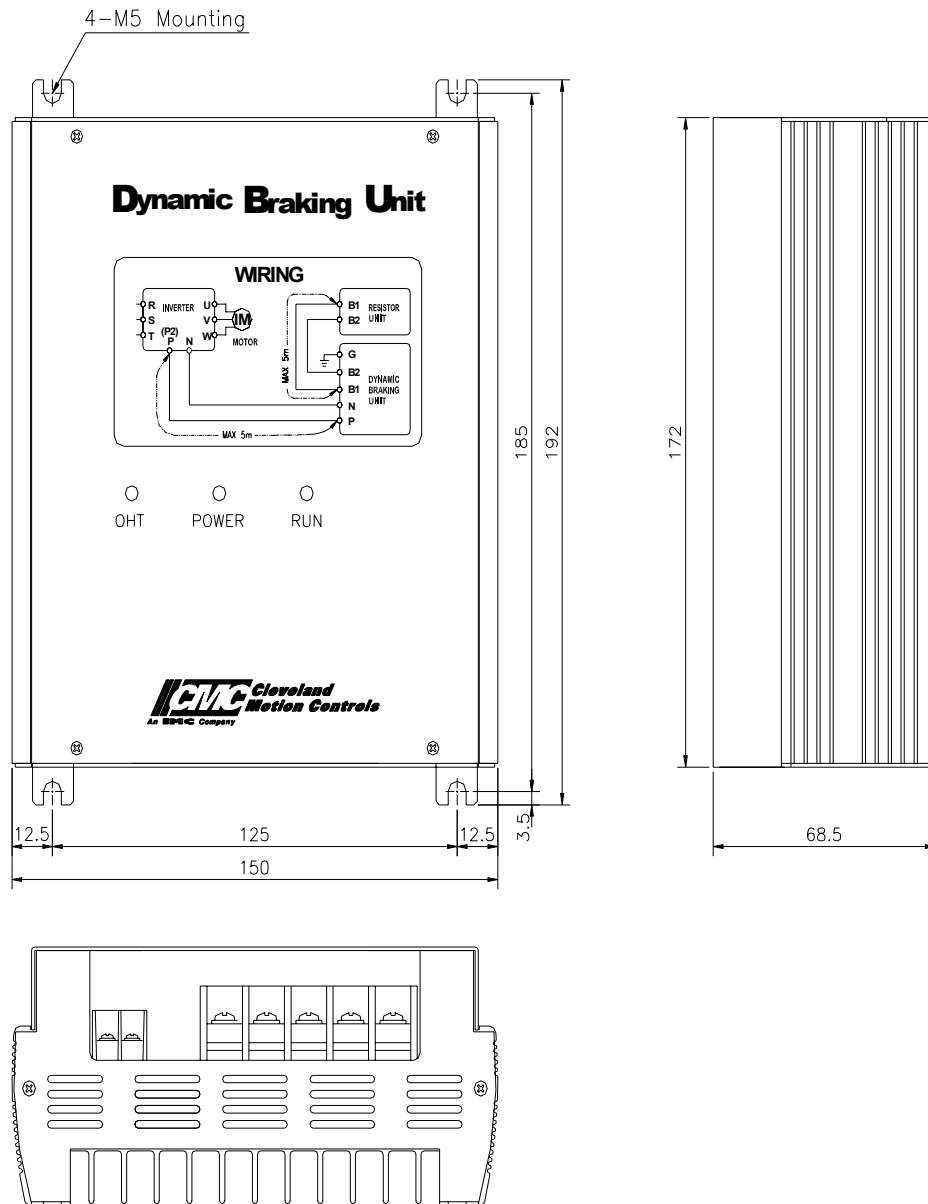

5) LED Indicator lamp description

DBU has three LED indicator lamps.

Display	Description
POWER	Power LED turns Red when input power is applied to DBU.
RUN	RUN LED is blinking while the DBU is activated by motor regenerating energy.
OHT	The unit shuts down the output and turns OHT LED ON when the heatsink is overheated in operation by its protection function.

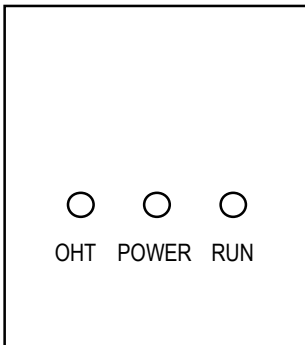

- ▶ POWER LED (Red) : indicates input power is applied.
- ▶ RUN LED (Green) : indicates Dynamic braking is active.
- ▶ OHT LED (Green) : indicates Over Heat Trip occurs

7.6.4 Micro surge filter (Designed for Inverter-driven 400V Class motor)

In the PWM type inverter, a surge voltage attributable to wiring constants is generated at the motor terminals. Especially for a 400V class motor, the surge voltage may deteriorate the insulation. When the 400V class motor is driven by the inverter, consider the following measures:

Measures

It is recommended to taking either of the following measures:

1) Rectifying the motor insulation

For the 400V class motor, use an insulation-rectified motor. Specifically,

- 1) Specify the “400V class inverter-driven, insulation-rectified motor”.
- 2) For the dedicated motor such as the constant-torque motor and low-vibration motor, use the “inverter-driven, dedicated motor”.

2) Suppressing the surge voltage on the inverter output side

On the secondary side of the inverter, connect the optional surge voltage suppression filter.

◆ Wiring

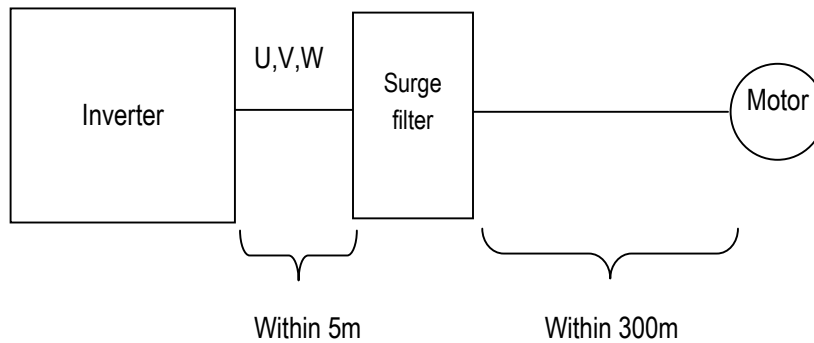

◆ Caution

- _ Check the Input/Output when wiring the filter.
- _ Wiring distance from inverter output to filter input should not exceed 5 meter.
- _ Wiring distance from filter to motor should not exceed 300 meter .

CHAPTER 8 - TROUBLESHOOTING & MAINTENANCE

8.1 Fault Display

When a fault occurs, the inverter turns off its output and displays the fault status in DRV-07. The last 5 faults are saved in FU2-01 through FU2-05 with the operation status at the instance of fault.

Keypad Display		Protective Function	Description
LCD	7-Segment		
Over Current 1	OC1	Over Current Protection	The inverter turns off its output when the output current of the inverter flows more than 200% of the inverter rated current.
Ground Fault	GF	Ground Fault Protection	The inverter turns off its output when a ground fault occurs and the ground fault current is more than the internal setting value of the inverter. Over current trip function may protect the inverter when a ground fault occurs due to a low ground fault resistance.
Over Voltage	OV	Over voltage protection	The inverter turns off its output if the DC voltage of the main circuit increases higher than the rated value when the motor decelerates or when regenerative energy flows back to the inverter due to a regenerative load. This fault can also occur due to a surge voltage generated at the power supply system.
Over Load	OLT	Current Limit Protection (Overload Protection)	The inverter turns off its output if the output current of the inverter flows at 180% of the inverter rated current for more than the current limit time (S/W).
Fuse Open	FUSE	Fuse Open	The inverter turns off its output by opening the fuse when something is wrong with the main circuit IGBT to protect the wiring from being damaged from short currents.
Over Heat	OH	Heat Sink Over Heat	The inverter turns off its output if the heat sink over heats due to a damaged cooling fan or an alien substance in the cooling fan by detecting the temperature of the heat sink.
E-Thermal	ETH	Electronic Thermal	The internal electronic thermal of the inverter determines the over heating of the motor. If the motor is overloaded the inverter turns off the output. The inverter cannot protect the motor when driving a multi-pole motor or when driving multiple motors, so consider thermal relays or other thermal protective devices for each motor. Overload capacity: 150% for 1 min
Ext Trip-A	EXTA	External fault A	Use this function if the user needs to turn off the output by an external fault signal. (Normal Open Contact)
Ext Trip-B	EXTB	External fault B	Use this function if the user needs to turn off the output by an external fault signal. (Normal Close Contact)
Low Voltage	LV	Low Voltage Protection	The inverter turns off its output if the DC voltage is below the detection level because insufficient torque or over heating of the motor can occurs when the input voltage of the inverter drops.
Over Current 2	OC2	IGBT Short	The inverter turns off the output if an IGBT short through or an output short occurs.
Out Phase Open	OPO	Output Phase open	The inverter turns off its output when the one or more of the output (U, V, W) phase is open. The inverter detects the output current to check the phase open of the output.
BX	BX	BX Protection (Instant Cut Off)	Used for the emergency stop of the inverter. The inverter instantly turns off the output when the BX terminal is turned ON, and returns to regular operation when the BX terminal is turned OFF. Take caution when using this function.
Over Speed	OSPD	Overspeed Protection	Inverter turns off its output when the motor runs in excess of Max. speed + 20Hz.

Keypad Display		Protective Function	Description
LCD	7-Segment		
Option (**)	OPT	Option Fault	Fault at the internal option of the inverter.
HW-Diag	HW	Inverter H/W Fault	A fault signal is output when an error occurs to the control circuitry of the inverter. There are the Wdog error, the EEP error, and the ADC Offset for this fault
COM Error CPU Error	Err	Communication Error	This fault is displayed when the inverter cannot communicate with the keypad.
LOP LOR LOV LOI LOX	LP LR LV LI LX	Operating Method when the Frequency Reference is Lost	According to the I/O-48 [Operating Method when the Frequency Reference is Lost] setting, there are three modes: continue operation, decelerate and stop, and free run, LOP: Displayed when option frequency reference is lost (DPRAM time out) LOR: Displayed when option frequency reference is lost (Communication network fault) LOV: Displayed when 'V1' analog frequency reference is lost. LOI: Displayed when 'I' analog frequency reference is lost. LOX: Displayed when sun-board (V2, ENC) analog frequency reference is lost.
Inv. OLT	IOLT	Inverter Overload	The inverter turns off its output when the output current of the inverter flows more than the rated level (150% for 1 minute, 200% for 0.5 seconds).
NTC open	NTC	Thermal Sensor Opened	Inverter uses NC thermal sensor for detecting heat sink temperature. If this message is displayed, the thermal sensor wire may be cut. (Inverter keeps operating)
MC Fail	MCF	Magnetic contactor fault	This fault is displayed when input power is not applied or M/C inside the inverter becomes faulty.

To reset fault perform **one** of the following:

- } Press **RESET** key on the keypad.
- } Close RST-CM terminals.
- } Cycle power to the inverter.

If a problem persists, please contact the factory or your local distributor.

8.2 Fault Remedy

Protective Function	Cause	Remedy
Over Current Protection	<ol style="list-style-type: none"> 1) Acceleration/Deceleration time is too short compared to the GD^2 of the load 2) Load is larger than the inverter rating 3) Inverter turns output on when the motor is free running. 4) Output short or ground fault has occurred 5) Mechanical brake of the motor is operating too fast 6) Components of the main circuit have overheated due to a faulty cooling fan 	<ol style="list-style-type: none"> 1) Increase Accel/Decel time 2) Increase inverter capacity. 3) Operate after motor has stopped 4) Check output wiring 5) Check mechanical brake operation 6) Check cooling fan <p>(Caution) Operating inverter prior to correcting fault may damage the IGBT</p>
Ground Current Protection	<ol style="list-style-type: none"> 1) Ground fault has occurred at the output wiring of inverter. 2) The insulation of the motor is damaged due to heat. 	<ol style="list-style-type: none"> 1) Investigate the output wiring of inverter 2) Exchange motor
Over Voltage Protection	<ol style="list-style-type: none"> 1) Acceleration time is too short compared to the GD^2 of load 2) Regenerative load at the output 3) Line voltage high 	<ol style="list-style-type: none"> 1) Increase deceleration time 2) Use regenerative resistor option 3) Check line voltage
Current Limit Protection (Overload Protection)	<ol style="list-style-type: none"> 1) Load is larger than the inverter rating 2) Selected incorrect inverter capacity 3) Set incorrect V/F pattern 	<ol style="list-style-type: none"> 1) Increase capacity of motor and inverter 2) Select correct inverter capacity 3) Select correct V/F pattern
Fuse Damage	<ol style="list-style-type: none"> 1) Damage due to repeated over current protection 2) Damage due to instant deceleration when motor is at an excessive excitation status. 	<p>Exchange the fuse</p> <p>(Caution) The IGBT receives damages on many occasions when Fuse Open Trip occurs</p>
Heat Sink Overheat	<ol style="list-style-type: none"> 1) Cooling fan damaged or an alien substance inserted 2) Cooling system has faults 3) Ambient temperature high 	<ol style="list-style-type: none"> 1) Exchange cooling fans and/or eliminate alien substance 2) Check for alien substances in the heat sink 3) Keep ambient temperature under 40 °C
Electronic Thermal	<ol style="list-style-type: none"> 1) Motor has overheated 2) Load is larger than inverter rating 3) ETH level too low 4) Selected incorrect inverter capacity 5) Set incorrect V/F pattern 6) Operated too long at low speeds 	<ol style="list-style-type: none"> 1) Reduce load and/or running duty 2) Increase inverter capacity 3) Adjust ETH level to an appropriate level 4) Select correct inverter capacity 5) Select correct V/F pattern 6) Install a cooling fan with a separate power supply
Ext Trip-A	External fault has occurred	Eliminate fault at circuit connected to external fault terminal or cause of external fault input
Ext Trip-B	External fault has occurred	Eliminate fault at circuit connected to external fault terminal or cause of external fault input
Low Voltage Protection	<ol style="list-style-type: none"> 1) Line voltage low 2) Load larger than line capacity is connected to line (welding machine, motor with high starting current connected to the commercial line) 3) Faulty magnetic switch at the input side of the inverter 	<ol style="list-style-type: none"> 1) Check line voltage 2) Increase line capacity 3) Exchange magnetic switch
Over Current 2	<ol style="list-style-type: none"> 1) Short has occurred between the upper and lower IGBT. 2) Short has occurred at the output of the inverter 3) Acceleration/Deceleration time is too short compared to the GD^2 of load 	<ol style="list-style-type: none"> 1) Check IGBT 2) Check output wiring of inverter 3) Increase acceleration time
Output Phase Open	<ol style="list-style-type: none"> 1) Faulty contact of magnetic switch at output 2) Faulty output wiring 	<ol style="list-style-type: none"> 1) Check magnetic switch at output of inverter 2) Check output wiring
Over Speed	<ol style="list-style-type: none"> 1) Faulty wiring of Encoder (A, B) 	<ol style="list-style-type: none"> 1) Check Encoder A, B signal wiring and wire them

Chapter 8 - Troubleshooting & Maintenance

Protective Function	Cause	Remedy
	2) Incorrect encoder parameter setting 3) Sub-B board or Encoder fault	correctly. 2) Check parameters of EXT-14,15,16 are set correctly. 3) Replace the faulty Sub-B board or Encoder to a new one.
Option Fault	Faulty option connector connection	Check option connection.
H/W Fault	1) Wdog error (CPU fault) 2) EEP error (memory fault) 3) ADC Offset (current feedback circuit fault)	Replace inverter
Communication Fault	1) Faulty connection between inverter and keypad 2) Inverter CPU malfunction	1) Check connector 2) Replace inverter
Operating Method when the Speed Reference is Lost	LOP (Loss of reference from the Option), LOR (Remote) LOV (V1), LOI (I), LOX (Sub-V2, ENC)	Eliminate cause of fault
Inverter Overload	1) Load is larger than inverter rating 2) Selected incorrect inverter capacity	1) Increase motor and/or inverter capacity 2) Select correct inverter capacity
Magnetic contactor fault	1) Damaged M/C operation detection contact 2) M/C malfunction	1) Check M/C operation detection contact is working properly. 2) Check M/C is working properly. Replace it, if needed.

8.3 Troubleshooting

Condition	Check Point
The Motor Does Not Rotate	1) Main circuit inspection: <ul style="list-style-type: none"> ☞ Is the input (line) voltage normal? (Is the LED in the inverter is lit?) ☞ Is the motor connected correctly? 2) Input signal inspection: <ul style="list-style-type: none"> ☞ Check the operating signal input to the inverter. ☞ Check the forward and the reverse signal input simultaneously to the inverter? ☞ Check the command frequency signal input to the inverter. 3) Parameter setting inspection: <ul style="list-style-type: none"> ☞ Is the reverse prevention (FU1-03) function set? ☞ Is the operation mode (FU1-01) set correctly? ☞ Is the command frequency set to 0? 4) Load inspection: <ul style="list-style-type: none"> ☞ Is the load too large or is the motor jammed? (Mechanical brake) 5) Other: <ul style="list-style-type: none"> ☞ Is the alarm displayed on the keypad or is the alarm LED lit? (STOP LED blinks)
The Motor Rotates in Opposite Directions	<ul style="list-style-type: none"> ☞ Is the phase sequence of the output terminal U, V, W correct? ☞ Is the starting signal (forward/reverse) connected correctly?
The Difference Between the Rotating Speed and the Reference is Too Large	<ul style="list-style-type: none"> ☞ Is the frequency reference signal correct? (Check the level of the input signal) ☞ Is the following parameter setting is correct? Lower Limit Frequency (FU1-24), Upper Limit Frequency (FU1-25), Analog Frequency Gain (I/O-1~10) ☞ Is the input signal line influenced by external noise? (Use a shielded wire)
The Inverter Does Not Accelerate or Decelerate Smoothly	<ul style="list-style-type: none"> ☞ Is the acceleration/deceleration time is set too short a period of time? ☞ Is the load too large? ☞ Is the Torque Boost (FU1-27, 28) value is too high that the current limit function and the stall prevention function do not operate?
The Motor Current is Too High	<ul style="list-style-type: none"> ☞ Is the load too large? ☞ Is the Torque Boost Value (manual) too high?
The Rotating Speed Does Not Increase	<ul style="list-style-type: none"> ☞ Is the Upper Limit Frequency (FU1-25) value correct? ☞ Is the load too large? ☞ Is the Torque Boost (FU1-27, 28) value too high that the stall prevention function (FU1-59, 60) does not operate?
The Rotating Speed Oscillates When the Inverter is Operating.	1) Load inspection: <ul style="list-style-type: none"> ☞ Is the load oscillating? 2) Input signal inspection: <ul style="list-style-type: none"> ☞ Is the frequency reference signal oscillating? 3) Other: <ul style="list-style-type: none"> ☞ Is the wiring too long when the inverter is using V/F control? (over 500m)

8.4 How to Check Power Components

Before checking the power components, be sure to disconnect AC Input supply and wait until the Main Electrolytic Capacitors (DCP-DCN) is discharged.

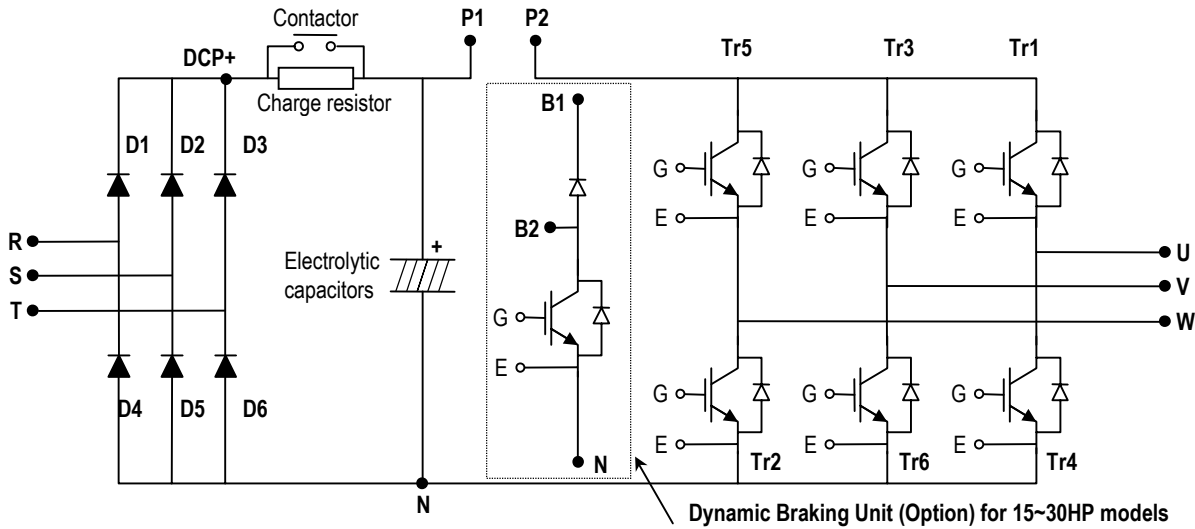

- 1) Disconnect the power input line (R, S, T) and the inverter output to the motor (U, V, W).
- 2) Verify whether the inverter terminal R, S, T, U, V, W, B1 (or P/L1), N is shorted or open by changing the polarity of the tester.
- 3) Verify capacitor has discharged before testing.
- 4) The tester should display several mega-ohms when open. The tester can display terminal is shorted for a short time and then display several mega-ohms because of the electrolytic capacitor. The tester should display $x \Omega \sim xx \Omega$ when terminal is shorted. If all measured values are about the same, individual modules are OK.
- 4) Diode module and IGBT module checking points:

Elements		Test Polarity		Measured Value	Element	Test Polarity		Measured Value
		+	-			+	-	
Diode Module	D1	R	DCP+	Short	D4	R	N	Open
		DCP+	R	Open		N	R	Short
	D2	S	DCP+	Short	D5	S	N	Open
		DCP+	S	Open		N	S	Short
	D3	T	DCP+	Short	D6	T	N	Open
		DCP+	T	Open		N	T	Short
IGBT Module	Tr1	U	B1	Short	Tr4	U	N	Open
		B1	U	Open		N	U	Short
	Tr3	V	B1	Short	Tr6	V	N	Open
		B1	V	Open		N	V	Short
	Tr5	W	B1	Short	Tr2	W	N	Open
		B1	W	Open		N	W	Short

8.5 Maintenance

The ACtionMaster series is an industrial electronic product with advanced semiconductor elements. However, temperature, humidity, vibration and aging parts may still affect it. To avoid this, it is recommended to perform routine inspections.

8.5.1 Precautions

- Be sure to remove the drive power input while performing maintenance.
- Be sure to perform maintenance only after checking that the bus has discharged. The bus capacitors in the electronic circuit can still be charged even after the power is turned off.
- The correct output voltage can only be measured by using a rectifier voltage meter. Other voltage meters, including digital voltage meters, are likely to display incorrect values caused by the high frequency PWM output voltage of the drive.

8.5.2 Routine Inspection

Be sure to check the following before operation:

- The conditions of the installation location
- The conditions of the drive cooling
- Abnormal vibration
- Abnormal heating

8.5.3 Periodical Inspection

- Are there any loose bolt, nut or rust caused by surrounding conditions? If so, tighten them up or replace them.
- Are there any deposits inside the drive-cooling fan? If so, remove using air.
- Are there any deposits on the drive's PCB (Printed Circuit Boards)? If so, remove using air.
- Are there any abnormalities in the various connectors of the drive's PCB? If so, check the condition of the connector in question.
- Check the rotating condition of the cooling fan, the size and condition of the capacitors and the connections with the magnetic contactor. Replace them if there are any abnormalities.

8.5.4 Meggar Test

For Exterior main circuit, remove all cables from inverter terminals to ensure that test voltage is not applied to the inverter. Use DC 500V meggar and isolate the main power before starting measurement. If the test voltage is connected to the control circuit, remove all connection cables to the control circuit. Perform the Meggar test only between the common cables connected to the main circuit and ground.

Do not perform Dielectric Voltage Withstand test to Inverter. Otherwise, IGBT inside Inverter will be damaged.

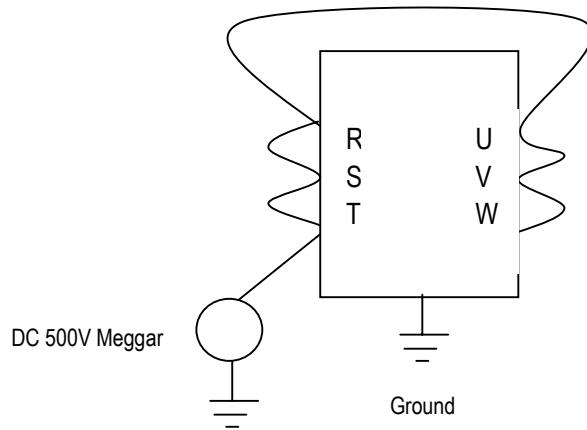

Figure 5 - Megger test

8.5.5 Parts Replacements

The life expectancy of a part depends on the type of part, the environment, and operating conditions. Parts should be replaced as shown below. When the internal fuse is opened the IGBT should be checked thoroughly before replacing the fuse. Contact the factory for fuse replacement information.

Part name	Standard period for replacement	Comments
Cooling fan	2~3 years	Exchange for a new part
Smoothing capacitor	5 years	Exchange for a new part
Other parts	-	Determine after checking

8.6 Daily and Periodic Inspection Items

Inspection Location	Inspection Item	Inspection	Period			Inspection Method	Criterion	Measuring Instrument
			Daily	1 year	2 year			
All	Ambient Environment	Is there any dust? Is the ambient temperature and humidity adequate?	O			Refer to the precautions	Temperature: -10~+40 no freezing. Humidity: Under 50% no dew	Thermometer, Hygrometer, Recorder
	Equipment	Is there any abnormal oscillation or noise	O			Use sight and hearing	No abnormality	
	Input Voltage	Is the input voltage of the main circuit normal	O			Measure the voltage between the terminals R, S, T		Digital Multi-Meter/Tester
Main Circuit	All	Megger check (between the main circuit and the ground) Are any fixed parts removed? Are there any traces of overheating at each component's cleaning?		O	O	Undo the inverter connections short the terminals R, S, T, U, V, W and measure between these parts and the ground. Tighten the screws. Visual check.	Over 5MΩ No fault	DC 500V class Megger
	Conductor/Wire	Is the conductor rusty? Is the wire coating damaged?		O		Visual check	No fault	
	Terminal	Is there any damage?		O		Visual check	No fault	
	IGBT Module /Diode Module	Check the resistance between each of the terminals.			O	Undo the inverter connection and measure the resistance between R, S, T ↔ P, N and U, V, W ↔ P, N with a tester.	(Refer "How to Check Power Components")	Digital Multi-Meter/Analog Tester
	Smoothing Capacitor	Is there any liquid coming out? Is the safety pin out, and is there any swelling? Measure the capacitance.	O	O		Visual check. Measure with a capacitance-measuring device.	No fault Over 85% of the rated capacity	Capacitance Measuring Device
	Relay	Is there any chattering noise during operation? Is there any damage to the contact		O		Auditory check. Visual check.	No fault	
	Resistor	Is there any damage to the resistor insulation? Is the wiring in the resistor damaged (open)?		O	O	Visual check. Disconnect one of the connections and measure with a tester.	No fault Error must be within ±10% the displayed resistance	Digital Multi-Meter/Analog Tester
Control Circuit Protective Circuit	Operation Check	Is there any unbalance between each phases of the output voltage?		O		Measure the voltage between the output terminals U, V and W.	The voltage balance between the phases for 200V (800V) class is under 4V (8V). The fault circuit operates according to the sequence.	Digital Multi-Meter/Rectifying Voltmeter
		Nothing must be wrong with display circuit after executing the sequence protective operation		O		Short and open the inverter protective circuit output.		
Cooling System	Cooling Fan	Is there any abnormal oscillation or noise? Is the connection area loose?	O	O		Turn OFF the power and turn the fan by hand. Tighten the connections.	Must rotate smoothly. No fault	
Display	Meter	Is the displayed value correct?	O	O		Check the meter reading at the exterior of the panel	Check the specified and management values.	Voltmeter/ Ammeter etc.
Motor	All	Are there any abnormal vibrations or noise? Is there any unusual odor?	O	O		Auditory, sensory, visual check. Check for overheat and damage.	No fault	
	Insulation Resistor	Megger check (between the output terminals and the ground terminal)			O	Undo the U, V and W connections and tie the motor wiring.	Over 5MΩ	500V class Megger

Note: Values in () is for the 400V class inverters.

APPENDIX A - FUNCTIONS BASED ON USE

Set the function properly according to the load and operating conditions. Application and related functions are listed in the following table.

Use	Related Parameter Code
Accel/Decel Time, Pattern Adjustment	DRV-01 [Acceleration Time], DRV-02 [Deceleration Time], FU1-05 [Acceleration Pattern], FU1-06 [Deceleration Pattern]
Reverse Rotation Prevention	FU1-03 [Forward, Reverse Prevention]
Minimum Accel/Decel Time	FU1-05 [Acceleration Pattern], FU1-06 [Deceleration Pattern]
Accel/Decel at Continuous Rating Range	FU1-05 [Acceleration Pattern], FU1-06 [Deceleration Pattern]
Braking Operation Adjustment	FU1-07 [Stop Method], FU1-08~11 [DC Braking], FU1-12~13 [DC braking at start]
Operations for Frequencies Over 60 Hz	FU1-20 [Maximum Frequency], FU1-25 [Frequency Upper Limit], I/O-05 [Frequency Corresponding to Max. Voltage of V1], I/O-10 [Frequency Corresponding to Max. Current of I]
Selecting an Appropriate Output Characteristics for the Load	FU1-20 [Maximum Frequency], FU1-21 [Base Frequency]
Motor Output Torque Adjustment	FU1-22 [Starting Frequency], FU1-26~28 [Torque Boost], FU1-59~60 [Stall Prevention], FU2-30 [Rated Motor]
Output Frequency Limit	FU1-23~25 [Frequency Upper/Lower Limit], I/O-01~10 [Analog Frequency Setting]
Motor Overheat Protection	FU1-50~53 [Electronic Thermal], FU2-30 [Rated Motor]
Multi Step Operation	I/O-12~14 [Define the Multi Function Input Terminals], I/O-20~27 [Jog, Multi Step Frequency], FU1-23~25 [Frequency Upper/Lower Limit]
Jog Operation	I/O-20 [Jog Frequency]
Frequency Jump Operation	FU2-10~16 [Frequency Jump]
Timing the Electronic Brake Operation	I/O-42~43 [Frequency Detection Level], I/O-44 [Multi Function Output]
Displaying the Rotating Speed	DRV-04 [Motor Speed], FU2-74 [Motor RPM Display Gain]
Function Alteration Prevention	FU2-94 [Parameter Lock]
Energy Saving	FU1-39 [Energy Saving]
Auto Restart Operation After Alarm Stop	FU2-27~28 [Auto Retry]
2 nd Motor Operation	FU2-81~90 [2 nd Function]
PID Feedback Operation	FU2-50~54 [PID Operation]
Frequency Reference Signal and Output Adjusting	I/O-01~10 [Analog Frequency Setting]
Define the Multi-Function Input Terminals	I/O-12~14 [Define the Multi-Function Input Terminals]
Define the Multi-Function Input Terminals	I/O-44 [Multi Function Auxiliary Contact Output Setting]
Commercial Line ↔ inverter Switchover Operation	I/O-12~14 [Define the Multi-Function Input Terminals], I/O-44 [Multi-Function Auxiliary Contact Output Setting]
Frequency Meter Calibration	I/O-40~41 [FM Output]
Operate by Communicating with a Computer	I/O-46 [Inverter No.], I/O-47 [communication Speed], I/O-48~49 [Loss of Reference]

APPENDIX B - PARAMETERS BASED ON APPLICATION

Application	Parameter Code
DRV Group	
When you want to change the frequency setting	DRV-00
When you want to change the acceleration and deceleration time of the motor	DRV-01, DRV-02
When you want to change the run/stop method	DRV-03
When you want to change the frequency reference source	DRV-04
When you want to set the multi-function	DRV-005 ~ 07
When you want to see the output current, motor speed and the DC link voltage of inverter	DRV-08 ~ 10
When you want to see the output voltage, output power, output torque from the user display	DRV-11
When you want to check the fault of the inverter	DRV-12
FU1 Group	
When you want to use the Jump Code	FU1-00
When you want to prevent the motor from rotating at opposite directions	FU1-03
When you want to select the acceleration and deceleration pattern suitable for your application	FU1-05 ~ 06
When you want to change the stopping method	FU1-07
When you want to change the stopping accuracy for steady stop	FU1-08 ~ 11
When DC injection braking is required before starting	FU1-12 ~ 13
When you want to set the maximum frequency and the base frequency according to the rated torque of the motor	FU1-20 ~ 21
When you want to adjust the starting frequency	FU1-22
When you want to limit the mechanical rotating speed to a fixed value	FU1-23 ~ 25
When a large starting torque is needed for loads such as elevators (Manual/Auto Torque Boost)	FU1-26 ~ 28
When you want to select an appropriate output characteristic (V/F characteristic) according to loads	FU1-29
When you want to set up your own V/F pattern	FU1-30 ~ 37
When you want to adjust the output voltage of the inverter	FU1-38
When you want to use the energy saving function	FU1-39
When you want to protect the motor from overheating	FU1-50 ~ 53
When you want to output a signal when the overload condition lasts more than a fixed amount of time	FU1-54 ~ 55
When you want to cut off the output when the overload condition lasts more than a fixed amount of time	FU1-56 ~ 58
When you want to set the stall prevention function	FU1-59 ~ 60
FU2 Group	
When you want to check the fault history of the inverter	FU2-01 ~ 06
When you want to use dwell function	FU2-07 ~ 08
When you want to prevent the resonance from the oscillating characteristics of a machine	FU2-10 ~ 16
When you want to protect inverter from input/output phase loss	FU2-19
When you want to start the inverter as soon as the power is turned ON	FU2-20
When you want to restart the inverter by resetting the fault when a fault occur	FU2-21
When you want to use the instant power failure restart function (Speed Search)	FU2-22 ~ 25
When you want to use the retry function	FU2-26 ~ 27
When you want to enter the motor constants	FU2-30 ~ 37
When you want to reduce noise or leakage current by changing the PWM carrier frequency	FU2-39
When you want to change the control method (V/F, slip compensation, PID, or sensorless operation)	FU2-40

Application	Parameter Code
When you want to use the auto tuning function	FU2-41 ~ 44
When you want to operate using PID feedback	FU2-50 ~ 54
When you want to change the reference frequency for acceleration and deceleration	FU2-70
When you want to change the acceleration and deceleration time scale	FU2-71
When you want to set the initial keypad display that is displayed when the power is turned ON	FU2-72
When you want to set the user defined display	FU2-73
When you want to adjust the gain for the motor RPM display	FU2-74
When you want to set the dynamic braking (DB) resistor mode	FU2-75 ~ 76
When you want to verify the inverter software version	FU2-79
When you want to change the connection from one motor to the other motor which use difference parameters	FU2-81 ~ 90
When you want to copy the inverter parameter to another inverter	FU2-91 ~ 92
When you want to initialize the parameters	FU2-93
When you want to prevent the parameters from being changed	FU2-94
I/O Group	
When you want to set the analog voltage or current for the frequency reference	I/O-01 ~ 10
When you want to set the operating method when the frequency reference is lost	I/O-11
When you want to change the functions for the input terminals P1, P2, and P3	I/O-12 ~ 14
When you want to check the status of the input/output terminals	I/O-15 ~ 16
When you want to change the response time of the input terminals	I/O-17
When you want to use the JOG and multi step speed operation	I/O-20 ~ 24
When you want to change the 1 st ~ 7 th acceleration/deceleration time	I/O-25 ~ 38
When you want to use the FM meter terminal output	I/O-40 ~ 41
When you want to set the frequency detection level	I/O-42 ~ 43
When you want to change the functions of the multi function auxiliary contact output (AXA-AXC)	I/O-44
When you want to exchange the motor to commercial power line from inverter or the opposite	I/O-44
When you want to use the fault relay (30A, 30B, 30C) functions	I/O-45
When you want to use RS232/485 communication	I/O-46 ~ 47
When you want to set the operating method when the frequency reference is lost	I/O-48 ~ 49
When you want to use the auto (sequence) operation	I/O-50 ~ 84
EXT Group (When a Sub-board and/or an option board is installed)	
When you want to define the functions for the input terminals P4, P5, P6 (SUB-A, SUB-C)	EXT-02 ~ 04
When you want to use the analog voltage (V2) input (SUB-A, SUB-C)	EXT-05 ~ 10
When you want to use the encoder pulse for feedback to control the motor speed, or use the pulse input for frequency reference (SUB-B)	EXT-14 ~ 24
When you want to change the functions of the output terminals Q1, Q2, Q3 (SUB-A, SUB-C)	EXT-30 ~ 32
When you want to use the LM meter terminal output (SUB-A, SUB-C)	EXT-34 ~ 35
When you want to use the analog outputs (AM1, AM2 terminals)	EXT-40 ~ 43

APPENDIX C - PERIPHERAL DEVICES

Inverter Models	Motor [HP]	MCCB, ELB (CMC)	Magnetic Contactor (CMC)	Wire, mm ² (AWG)			AC Input Fuse	AC Reactor	DC Reactor
				R, S, T	U, V, W	Ground			
SV008ACti onMaster-2	1	ABS33a, EBS33	SMC-10P	2 (14)	2 (14)	3.5 (12)	10 A	2.13 mH, 5.7 A	7.00 mH, 5.4 A
SV015ACti onMaster-2	2	ABS33a, EBS33	SMC-10P	2 (14)	2 (14)	3.5 (12)	15 A	1.20 mH, 10 A	4.05 mH, 9.2 A
SV022ACti onMaster-2	3	ABS33a, EBS33	SMC-15P	2 (14)	2 (14)	3.5 (12)	25 A	0.88 mH, 14 A	2.92 mH, 13 A
SV037ACti onMaster-2	5	ABS33a, EBS33	SMC-20P	3.5 (12)	3.5 (12)	3.5 (12)	40 A	0.56 mH, 20 A	1.98 mH, 19 A
SV055ACti onMaster-2	7.5	ABS53a, EBS53	SMC-25P	5.5 (10)	5.5 (10)	5.5 (10)	40 A	0.39 mH, 30 A	1.37 mH, 29 A
SV075ACti onMaster-2	10	ABS63a, EBS63	SMC-35P	8 (8)	8 (8)	5.5 (10)	50 A	0.28 mH, 40 A	1.05 mH, 38 A
SV110ACti onMaster-2	15	ABS103a, EBS103	SMC-50P	14 (6)	14 (6)	14 (6)	70 A	0.20 mH, 59 A	0.74 mH, 56 A
SV150ACti onMaster-2	20	ABS103a, EBS103	SMC-65P	22 (4)	22 (4)	14 (6)	100 A	0.15 mH, 75 A	0.57 mH, 71 A
SV185ACti onMaster-2	25	ABS203a, EBS203	SMC-80P	30 (3)	30 (3)	22 (4)	100 A	0.12 mH, 96 A	0.49 mH, 91 A
SV220ACti onMaster-2	30	ABS203a, EBS203	SMC-100P	38(2)	30 (3)	22 (4)	125 A	0.10 mH, 112 A	0.42 mH, 107 A
SV008ACti onMaster-4	1	ABS33a, EBS33	SMC-10P	2 (14)	2 (14)	2 (14)	6 A	8.63 mH, 2.8 A	28.62 mH, 2.7 A
SV015ACti onMaster-4	2	ABS33a, EBS33	SMC-10P	2 (14)	2 (14)	2 (14)	10 A	4.81 mH, 4.8 A	16.14 mH, 4.6 A
SV022ACti onMaster-4	3	ABS33a, EBS33	SMC-20P	2 (14)	2 (14)	2 (14)	10 A	3.23 mH, 7.5 A	11.66 mH, 7.1 A
SV037ACti onMaster-4	5	ABS33a, EBS33	SMC-20P	2 (14)	2 (14)	2 (14)	20 A	2.34 mH, 10 A	7.83 mH, 10 A
SV055ACti onMaster-4	7.5	ABS33a, EBS33	SMC-20P	3.5 (12)	2 (14)	3.5 (12)	20 A	1.22 mH, 15 A	5.34 mH, 14 A
SV075ACti onMaster-4	10	ABS33a, EBS33	SMC-20P	3.5 (12)	3.5 (12)	3.5 (12)	30 A	1.14 mH, 20 A	4.04 mH, 19 A
SV110ACti onMaster-4	15	ABS53a, EBS53	SMC-20P	5.5 (10)	5.5 (10)	8 (8)	35 A	0.81 mH, 30 A	2.76 mH, 29 A
SV150ACti onMaster-4	20	ABS63a, EBS63	SMC-25P	14 (6)	8 (8)	8 (8)	45 A	0.61 mH, 38 A	2.18 mH, 36 A
SV185ACti onMaster-4	25	ABS103a, EBS103	SMC-35P	14 (6)	8 (8)	14 (6)	60 A	0.45 mH, 50 A	1.79 mH, 48 A

SV220Acti onMaster-4	30	ABS103a, EBS103	SMC-50P	22 (4)	14 (6)	14 (6)	70 A	0.39 mH, 58 A	1.54 mH, 55 A
SV300Acti onMaster-4	40	ABS103a, EBS103	GMC-65	22 (4)	22 (4)	14 (6)		0.287mH, 80A	1.191mH, 76A
SV370Acti onMaster-4	50	ABS103a, EBS103	GMC-85	22 (4)	22 (4)	14 (6)		0.232mH, 98A	0.975mH, 93A
SV450Acti onMaster-4	60	ABS103a, EBS103	GMC-100	38(2)	38(2)	22 (4)		0.195mH, 118A	0.886mH, 112A
SV550Acti onMaster-4	75	ABS103a, EBS103	GMC-125	38(2)	38(2)	22 (4)		0.157mH, 142A	0.753mH, 135A
SV750Acti onMaster-4	100	ABS103a, EBS103	GMC-150	60(2/0)	60(2/0)	22 (4)		0.122mH, 196A	0.436mH, 187A

DECLARATION OF CONFORMITY

Council Directive(s) to which conformity is declared:

CD 73/23/EEC and CD 89/336/EEC

Units are certified for compliance with:

**EN50178 (1997)
EN 50081-2 (1993)
EN 55011 (1994)
EN 50082-2 (1995)
EN 61000-4-2 (1995)
ENV 50140 (1993) & ENV 50204 (1995)
EN 61000-4-4 (1995)
ENV 50141 (1993)
EN 61000-4-8 (1993)**

Type of Equipment:

Inverter (Power Conversion Equipment)

Model Name:

SV - ACTIONMaster Series

Trade Mark:

Cleveland Motion Controls

Representative:

IMC, International Motion Controls

Address:

**369 Franklin Street
Buffalo, New York , 14202
USA**

Manufacturer:

Cleveland Motion Controls.

Address:

**7550 Hub Parkway
Cleveland, Ohio, 44125
USA**

TECHNICAL STANDARDS APPLIED

The standards applied in order to comply with the essential requirements of the Directives 73/23/CEE "Electrical material intended to be used with certain limits of voltage" and 89/336/CEE "Electromagnetic Compatibility" are the following ones:

• EN 50178 (1997)	"Safety of information technology equipment".
• EN 50081-2 (1993)	"Electromagnetic compatibility. Generic emission standard. Part 2: Industrial environment."
• EN 55011 (1994)	"Limits and methods of measurements of radio disturbance characteristics of industrial, scientific and medical (ISM) radio frequency equipment."
• EN 50082-2 (1995)	"Electromagnetic compatibility. Generic immunity standard. Part 2: Industrial environment."
• EN 61000-4-2 (1995)	"Electromagnetic compatibility (EMC). Part 4: Testing and measurement techniques. Section 2: Electrostatic discharge immunity test. Basic EMC Publication (IEC 1000-4-2: 1995)."
• ENV 50140 (1993)	"Electromagnetic compatibility - Basic immunity standard - Radiated radio- frequency electromagnetic field - Immunity test."
• ENV 50204 (1995)	"Radio electromagnetic field from digital radio telephones."
• EN 61000-4-4 (1995)	"Electromagnetic compatibility (EMC). Part 4: Testing and measurement techniques. Section 4: Electrical fast transients / burst immunity test. Basic EMC Publication (IEC 1000-4-4: 1995)."
• ENV 50141 (1993)	"Electromagnetic compatibility. Basic immunity standard. Conducted disturbances induced by radio-frequency fields."
• EN 61000-4-8 (1993)	"Electromagnetic compatibility (EMC). Part 4: Testing and measurement techniques. Section 8: Power frequency magnetic field immunity test - Basic EMC Publication (IEC 1000-4-8: 1993)."

EMC INSTALLATION GUIDE

CMC inverters are tested to meet Electromagnetic Compatibility (EMC) Directive 89/336/EEC and Low Voltage (LV) Directive 73/23/EEC using a technical construction file. However, Conformity of the inverter with CE EMC requirements does not guarantee an entire machine installation complies with CE EMC requirements. Many factors can influence total machine installation compliance.

Essential Requirements for CE Compliance

Following conditions must be satisfied for CMC inverters to meet the CE EMC requirements.

1. CE compatible CMC inverter
2. Installing inverter in an EMC enclosure
3. Grounding enclosure and shielded parts of wire
4. RFI filter on inverter input side
5. Using shielded cable
1. Ferrite core on inverter output side

RFI FILTERS

THE L.G. RANGE OF POWER LINE FILTERS FF (Footprint) – FE (Standard) SERIES, HAVE BEEN SPECIFICALLY DESIGNED WITH HIGH FREQUENCY CMC INVERTERS. THE USE L.G. FILTERS, WITH THE INSTALLATION ADVICE OVERLEAF HELP TO ENSURE TROUBLE FREE USE ALONG SIDE SENSITIVE DEVICES AND COMPLIANCE TO CONDUCTED EMISSION AND IMMUNITY STANDARDS TO EN50081

CAUTION

IN CASE OF A LEAKAGE CURRENT PROTECTIVE DEVICES IS USED ON POWER SUPPLY, IT MAY BE FAULT AT POWER-ON OR OFF.
IN AVOID THIS CASE, THE SENSE CURRENT OF PROTECTIVE DEVICE SHOULD BE LARGER THAN VALUE OF LAKAGE CURRENT AT WORST CASE IN THE BELOW TABLE.

RECOMMENDED INSTALLATION INSTRUCTIONS

To conform to the **EMC** directive, it is necessary that these instructions be followed as closely as possible. Follow the usual safety procedures when working with electrical equipment. All electrical connections to the filter, inverter and motor must be made by a qualified electrical technician.

- 1-) *Check the filter rating label to ensure that the current, voltage rating and part number are correct.*
- 2-) *For best results the filter should be fitted as closely as possible to the incoming mains supply of the wiring enclosure, usually directly after the enclosures circuit breaker or supply switch.*
- 3-) *The back panel of the wiring cabinet of board should be prepared for the mounting dimensions of the filter. Care should be taken to remove any paint etc. from the mounting holes and face area of the panel to ensure the best possible earthing of the filter.*
- 4-) *Mount the filter securely.*
- 5-) *Connect the mains supply to the filter terminals marked **LINE**, connect any earth cables to the earth stud provided. Connect the filter terminals marked **LOAD** to the mains input of the inverter using short lengths of appropriate gauge cable.*
- 6-) *Connect the motor and fit the ferrite core (output chokes) as close to the inverter as possible. Armoured or screened cable should be used with the 3 phase conductors only threaded twice through the center of the ferrite core. The earth conductor should be securely earthed at both inverter and motor ends. The screen should be connected to the enclosure body via and earthed cable gland.*

7-) Connect any control cables as instructed in the inverter instructions manual.
IT IS IMPORTANT THAT ALL LEAD LENGTHS ARE KEPT AS SHORT AS POSSIBLE AND THAT INCOMING MAINS AND OUTGOING MOTOR CABLES ARE KEPT WELL SEPARATED.

FF SERIES (Footprint)

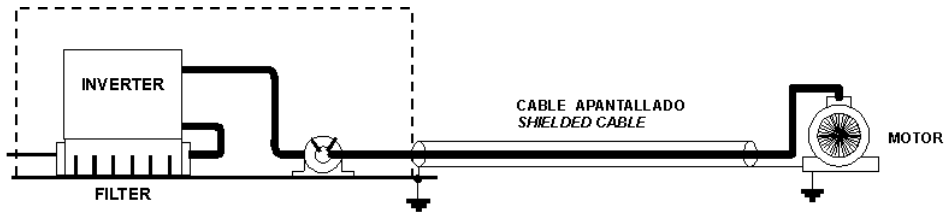

FE SERIES (Standard)

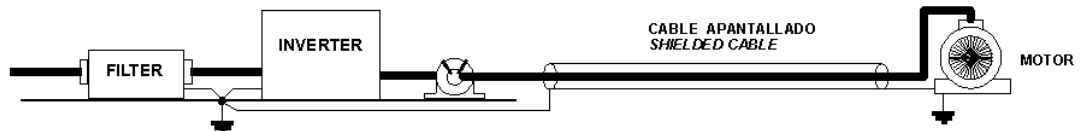

RFI Filters (Footprint - Standard) for ACTIONMASTER SERIES

iS5 series / Filtros Footprint / Footprint Filters													
VARIADOR INVERTER	POT. POWER	CODIGO CODE	INTENS. CURRENT	TENSION VOLTAGE	CORRIENTE DE FUGAS LEAKAGE CURRENT		DIMENSIONES DIMENSIONS L W H			MONTAJE MOUNTING Y X	PESO WEIGHT	TORNILLOS DE FIJACION MOUNT	CHOQUES DE SALIDA OUTPUT CHOKES
TRIFASICOS THREE PHASE		NOM. MAX.											
SV008iS5-2	0.8kW	FFS5-T012-(x)	12A	250VAC	0.3A	18A	329 x 149.5 x 50	315 x 120				M5	FS - 2
SV015iS5-2	1.5kW												
SV022iS5-2	2.2kW	FFS5-T020-(x)	20A	250VAC	0.3A	18A	329 x 149.5 x 50	315 x 120				M5	FS - 2
SV037iS5-2	3.7kW												
SV055iS5-2	5.5kW	FFS5-T030-(x)	30A	250VAC	0.3A	18A	415 x 199.5 x 60	401 x 160				M5	FS - 2
SV075iS5-2	7.5kW												
SV110iS5-2	11kW		100A	250VAC	0.3A	18A							FS - 3
SV150iS5-2	15kW												
SV185iS5-2	18kW		120A	250VAC	0.3A	18A							FS - 3
SV220iS5-2	22kW												
SV008iS5-4	0.8kW	FFS5-T006-(x)	6A	380VAC	0.5A	27A	329 x 149.5 x 50	315 x 120				M5	FS - 1
SV015iS5-4	1.5kW												
SV022iS5-4	2.2kW	FFS5-T012-(x)	12A	380VAC	0.5A	27A	329 x 149.5 x 50	315 x 120				M5	FS - 2
SV037iS5-4	3.7kW												
SV055iS5-4	5.5kW	FFS5-T030-(x)	30A	380VAC	0.5A	27A	415 x 199.5 x 60	401 x 160				M5	FS - 2
SV075iS5-4	7.5kW												
SV110iS5-4	11kW	FFS5-T051-(x)	51A	380VAC	0.5A	27A	466 x 258 x 65	440.5 x 181				M8	FS - 2
SV150iS5-4	15kW												
SV185iS5-4	18kW	FFS5-T060-(x)	60A	380VAC	0.5A	27A	541 x 332 x 65	515.5 x 255				M8	FS - 2
SV220iS5-4	22kW												
		FFS5-T070-(x)	70A	380VAC	0.5A	27A	541 x 332 x 65	515.5 x 255				M8	FS - 2

iS5 series / Filtros Estándar / Standard Filters													
VARIADOR INVERTER	POT. POWER	CODIGO CODE	INTENS. CURRENT	TENSION VOLTAGE	CORRIENTE DE FUGAS LEAKAGE CURRENT		DIMENSIONES DIMENSIONS L W H			MONTAJE MOUNTING Y X	PESO WEIGHT	TORNILLOS DE FIJACION MOUNT	CHOQUES DE SALIDA OUTPUT CHOKES
TRIFASICOS THREE PHASE		NOM. MAX.											
SV008iS5-2	0.8kW	FE-T012-(x)	12A	250VAC	0.3A	18A	250 x 110 x 60	238 x 76				---	FS - 2
SV015iS5-2	1.5kW												
SV022iS5-2	2.2kW	FE-T020-(x)	20A	250VAC	0.3A	18A	270 x 140 x 60	258 x 106				---	FS - 2
SV037iS5-2	3.7kW												
SV055iS5-2	5.5kW	FE-T030-(x)	30A	250VAC	0.3A	18A	270 x 140 x 60	258 x 106				---	FS - 2
SV075iS5-2	7.5kW												
SV110iS5-2	11kW	FE-T100-(x)	100A	250VAC	0.3A	18A	420 x 200 x 130	408 x 166				---	FS - 3
SV150iS5-2	15kW												
SV185iS5-2	18kW	FE-T120-(x)	120A	250VAC	1.3A	180A	420 x 200 x 130	408 x 166				---	FS - 3
SV220iS5-2	22kW												
SV008iS5-4	0.8kW	FE-T006-(x)	6A	380 VAC	0.5A	27A	250 x 110 x 60	238 x 76				---	FS - 2
SV015iS5-4	1.5kW												
SV022iS5-4	2.2kW	FE-T012-(x)	12A	380 VAC	0.5A	27A	250 x 110 x 60	238 x 76				---	FS - 2
SV037iS5-4	3.7kW												
SV055iS5-4	5.5kW	FE-T030-(x)	30A	380 VAC	0.5A	27A	270 x 140 x 60	258 x 106				---	FS - 2
SV075iS5-4	7.5kW												
SV110iS5-4	11kW	FE-T050-(x)	50A	380VAC	0.5A	27A	270 x 140 x 90	258 x 106				---	FS - 2
SV150iS5-4	15kW												
SV185iS5-4	18kW	FE-T060-(x)	60A	380VAC	0.5A	27A	270 x 140 x 90	258 x 106				---	FS - 2
SV220iS5-4	22kW												
		FE-T070-(x)	70A	380VAC	0.5A	27A	350 x 180 x 90	338 x 146				---	FS - 2

(x) (1) Industrial environment EN 50081-0 (A class)

(2) Domestic and industrial environment EN 50081-1 (B class)

DIMENSIONS

FF SERIES (Footprint)

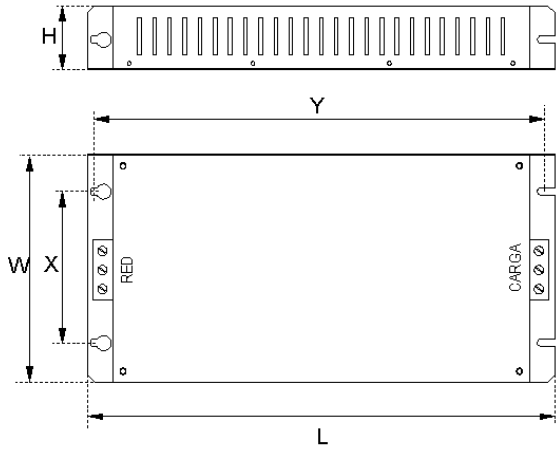

FE SERIES (Standard)

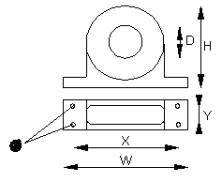
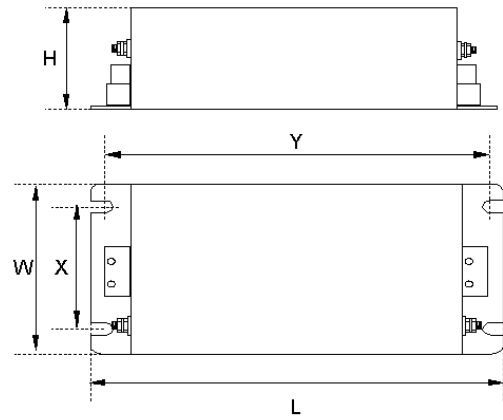

FS SERIES (output chokes)

TIPO	D	W	H	X	O
FS - 1	21	85	46	70	5
FS - 2	28.5	105	62	90	5
FS - 3	48	150	110	125 x 30	5
FS - 4	58	200	170	180 x 45	5

Revisions

	Publication date	Ordering Number	Changes to be made	Software Version No.	Note
1	Feb, 1999			1.00	
2	April, 2000			1.03	
3	March, 2001			1.05	
4	July, 2001			1.06	
5	May, 2002			1.07	
6	June, 2002			2.00	



Cleveland Motion Controls

CMC constantly endeavors to improve its product so that information in this manual is subject to change without notice.

Visit Our Website: <http://www.cmcccontrols.com/>

10/11/2002
Publication #: 10310000291