

Action Master

Series **H**

40 - 300 HP

230V, 460V

Installation, Operation and Maintenance Manual



CMC **Cleveland**
Motion Controls
An **IMC** Company

 **WARNING**

Electrical Shock Prevention

1. Do not remove the front cover when input power is applied. Doing so can result in electric shock.
2. Do not operate the inverter with the front cover removed. Electric shock can occur due to the exposed high voltage terminals and capacitor.
3. Do not remove the cover except for routine inspections or wiring, even if the input power is not applied. The capacitor will remain charged for a long time even when the power is not applied.
4. Wiring and routine checkups should be performed 10 minutes after disconnecting the input power and after checking to see whether the DC voltage is discharged with a tester. (Below DC 30V)
5. Do not use a higher grounding method than the Type 3 grounding method.
6. Only authorized personnel may perform wiring and inspections.
7. Wire the inverter after the inverter installation.
8. Do not operate the switches with wet hands. Doing so may result in electrical shock.
9. Electrical shock may occur if the cable insulation is damaged. Insure proper mounting of equipment to minimize excess stress on power cables.

 **CAUTION**

Fire Prevention

1. Install the inverter on a non-combustible surface. Installing the inverter on or near combustible materials can result in fire.
2. Disconnect the inverter when the inverter is damaged. Failure to do so could lead to a secondary accident and fire.
3. Do not connect a resistance directly between the DC terminals P. N. Doing so can result in fire.

Damage Prevention

1. Do not apply voltages higher than the values specified in this manual to the terminals. Doing so can damage the inverter.
2. Incorrect terminal connection may damage the inverter.
3. Incorrectly connecting the polarity (+/-) of the terminals can damage the inverter.
4. After disconnecting, the inverter may still be hot. Use caution to prevent the possibility of personal injury.

Other Important Precautions

Pay attention to the following items. Failure to do so can result in damage of inverter and/or electrical shock.

Handling and installation

1. Handle according to the weight of product. Failure to do so can result in damage to product.
2. Do not stack inverters beyond listed specifications.
3. Install according to specifications listed within this manual.
4. Do not apply power to a damaged inverter or to an inverter with missing components.
5. Do not open front cover while carrying inverter.
6. Do not place heavy items on inverter.
7. Installation orientation must follow specifications listed within this manual.
8. Do not allow conducted material such as screws, metal objects, water, or oil to enter interior of inverter.
9. Do not drop or inflict intense impact to inverter.
10. Install and operate inverter only under specified conditions.
5. Do not modify or alter anything inside inverter.
6. CAUTION: Motor might not be protected by electronic thermal function of inverter.
7. Install noise filter to minimize potential noise interference on equipment installed near inverter.
8. In case of input voltage unbalance, install AC reactor. Power Factor capacitors and generators may become overheated and damaged due to potential high frequency noise transmitted from inverter.
9. Use an insulation-rectified motor or take measures to suppress the micro surge voltage when driving 400V class motor with inverter. A micro surge voltage attributable to wiring constant is generated at motor terminals, and may deteriorate insulation and damage motor
10. Before operating unit and prior to user programming, reset user parameters to default settings
11. Inverter can easily be set to high-speed operations, Verify capability of motor or machinery prior to operating unit.
12. Stopping torque is not produced when using the DC-Break function. Install separate equipment when stopping torque is needed.

Wiring

1. Do not connect Power Factor capacitors, surge suppressors, or RFI filters to output circuits.
2. Connect the output terminals (U, V, W) according to specifications.

Operation

1. CAUTION: When the retry function is selected the inverter restarts after an alarm stop.
2. Stop key on keypad can only be used when stop key function is set. Install separate emergency stop switch if required.
3. When run signal is received, inverter restarts only when alarm contents have been reset. Verify run signal before resetting alarm.
4. Do not start or stop inverter using electromagnetic switch installed in power input circuit.

Fault Prevention Precautions

Install additional safety equipment, such as emergency brakes, to prevent uncontrolled machine operation from a damaged inverter.

Maintenance, Inspection, and Exchanging Components

1. Do not conduct megger test (insulation resistance measurement) of control circuitry in inverter.
2. Refer to **Chapter 7** for routine inspection methods.

General Precautions

The diagrams in this manual may show removed inverter covers and removed circuit breakers. Prior to operating unit, be sure to restore covers and circuit breakers according to specifications.

Table of Contents

USER SELECTION GUIDE (Series H SPECIFICATIONS).....	3
CHAPTER 1 - INSTALLATION	5
1.1 Inspection	5
1.2 Environmental Conditions.....	5
1.3 Mounting.....	5
1.4 Dimensions.....	6
1.5 Basic Wiring.....	9
1.6 Control Terminals.....	10
1.7 Power Terminals.....	11
CHAPTER 2 - OPERATION	15
2.1 Display.....	15
2.2 Alpha-numerical Display	16
2.3 Operation.....	16
2.4 Procedure of setting data.....	17
2.5 Parameter Navigation.....	18
2.6 Control Method.....	19
CHAPTER 3 - QUICK START UP.....	21
3.1 Easy Start Up (Drive Control through Keypad).....	21
3.2 Control Terminal Operation – External Start, Stop and Speed Reference.....	23
3.3 Operation with both Control Terminals and Keypad	25
CHAPTER 4 - PARAMETER LIST	27
4.1 Drive Group.....	27
4.2 Function Group.....	27
4.3 I/O Group	32
CHAPTER 5 - PARAMETER DESCRIPTION.....	36
5.1 Drive Group.....	36
5.2 Function Group.....	38
5.3 I/O Group	60
CHAPTER 6 - ADVANCED FEATURES	74
6.1 Acceleration / Deceleration	74
6.2 Auto-Restart / Speed Search	76
6.3 D.C. Injection Braking	80
6.4 Drive Protection.....	81
6.5 Energy Saving	85
6.6 Frequency Reference.....	86

6.7	Frequency Jump	91
6.8	Frequency Output Monitor.....	92
6.9	Jog	94
6.10	Motor Data.....	95
6.11	Multi-Function Inputs.....	96
6.12	Multi-Function Outputs	102
6.13	Drive Operation Monitor	108
6.14	Option Card	111
6.15	P.I. Control	113
6.16	Resetting Fault	114
6.17	Sequential Reference.....	114
6.18	V/F Pattern.....	114
CHAPTER 7 - TROUBLESHOOTING.....		117
7.1	How to Check Power Components.....	117
7.2	Fault Trip Description	118
CHAPTER 8 - MAINTENANCE.....		124
8.1	Precautions.....	124
8.2	Routine Inspection.....	124
8.3	Periodical Inspection	124
8.4	Internal Fuse Replacement.....	124
CHAPTER 9 - APPLICATION NOTES.....		126
9.1	Multi-Step Speed (Pre-set Speed) Operation	127
9.2	3-Wire Operation.....	129
9.3	Exchange Inverter to Commercial Line Operation	131
9.4	Up and Down Operation	133
DETAILED DIMENSIONS.....		136

USER SELECTION GUIDE (Series H SPECIFICATIONS)

230V Class (40 – 75HP)

Inverter Model Number ACM-xxxH-2		030H-2	037H-2	045H-2	055H-2
Applicable Motor	Constant Torque (HP)	40	50	60	75
	Constant Torque (kW)	30	37	45	55
	Variable Torque (HP)				
	Variable Torque (kW)				
Output Ratings	Constant Torque (FLA)	122	146	180	220
	Variable Torque (FLA)				
Input Ratings	Input Voltage	3 Phase, 200 to 230 V (± 10%)			
	Input Frequency	50 to 60 Hz (± 5%)			
Weight (lbs.)		88	88	132	132

460V Class (40 - 75HP)

Inverter Model Number ACM-xxxH-4		030H-4	037H-4	045H-4	055H-4
Applicable Motor	Constant Torque (HP)	40	50	60	75
	Constant Torque (kW)	30	37	45	55
	Variable Torque (HP)				
	Variable Torque (kW)				
Output Ratings	Constant Torque (FLA)	61	75	91	110
	Variable Torque (FLA)				
Input Ratings	Input Voltage	3 Phase, 380 to 460 V (± 10%)			
	Input Frequency	50 to 60 Hz (± 5%)			
Weight (lbs.)		99	99	143	143

460V Class (100 - 215HP)

Inverter Model Number ACM-xxxH-4		075H-4	090H-4	110H-4	132H-4	160H-4
Applicable Motor	Constant Torque (HP)	100	125	150	175	215
	Constant Torque (kW)	75	90	110	132	160
	Variable Torque (HP)					
	Variable Torque (kW)					
Output Ratings	Constant Torque (FLA)	152	183	223	264	325
	Variable Torque (FLA)					
Input Ratings	Input Voltage	3 Phase, 380 to 460 V (± 10%)				
	Input Frequency	50 to 60 Hz (± 5%)				
Weight (lbs.)		198	209	220	264	275

460V Class (300HP)

Inverter Model Number ACM-xxxH-4		220H-4			
Applicable Motor	Constant Torque (HP)	290			
	Constant Torque (kW)	220			
	Variable Torque (HP)				
	Variable Torque (kW)				
Output Ratings	Constant Torque (FLA)	432			
	Variable Torque (FLA)				
Input Ratings	Input Voltage	3 Phase, 380 to 460 V ($\pm 10\%$)			
	Input Frequency	50 to 60 Hz ($\pm 5\%$)			
Weight (lbs.)		275			

All Models

Output Ratings	Max. Frequency	0.5 to 400 Hz
	Output Voltage	3 Phase, 0 to Input Voltage
Control	Control Method	Space Vector PWM
	Frequency Resolution	0.01 Hz
	Frequency Accuracy	0.01% of Maximum Frequency (Digital Setting) 0.1% of Maximum Frequency (Analog Setting)
	V/F Ratio	Linear, Non-linear, User Programmable
	Braking Torque(w/o DB)	About 20%
	Overload Capacity CT	150% for 1 minute
	Overload Capacity VT	120% for 1 minute
	Torque Boost	0 to 20% programmable
Operating	Operation Method	Key-pad Control Terminal Control Remote (Option)
	Frequency Setting	Analog: 0 to 10 V / 4 to 20 mA Digital: using Key-pad
	Acceleration / Deceleration Time	0.1 to 6,000 sec 8 Pre-defined Acc. / Dec. Ramp (Programmable)
	Multi-Step	8 Preset Operation Speed (Programmable)
Programmable I/O	Programmable Input	6 Programmable Inputs
	Programmable Output	5 Programmable Outputs
Protective Functions	Inverter Trip	Overvoltage, Undervoltage, Overcurrent, Fuse Open, Ground Fault, Inverter Overheat, Motor Overheat, Main CPU Error.
	Stall Prevention	Over-current Prevention
	Instant Power Failure	Below 15 msec: continuous operation Over 15 msec: auto restart (programmable)
Operating Condition	Ambient Temperature	14 °F to 104 °F (-10 °C to 40 °C)
	Humidity	Below 90% Relative Humidity (Non Condensing)
	Altitude	Less than 3,300ft (1,000m) without de-rating
	Cooling System	Forced Air Cooling

CHAPTER 1 - INSTALLATION

1.1 Inspection

- Inspect the inverter for any damage that may have occurred during shipping.
- Check the nameplate for the Series H inverter. Verify that the inverter unit is the correct one for the application. The numbering system of a CMC inverter is as below.

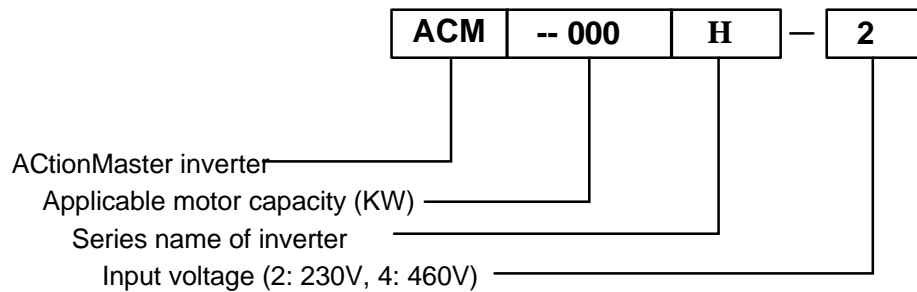

1.2 Environmental Conditions

- Verify that ambient condition of the mounting location. Ambient temperature should not be below 14°F (-10°C) and must not exceed 104°F (40°C). Relative humidity should be less than 90% (non-condensing). The altitude should be below 3,300ft (1,000m).
- Do not mount the inverter in direct sunlight. Isolate the inverter from excessive vibration.

1.3 Mounting

- The Series H must be mounted vertically with sufficient space (horizontally and vertically) between adjacent equipment (A: over 6" (150mm), B: over 2" (50mm)).

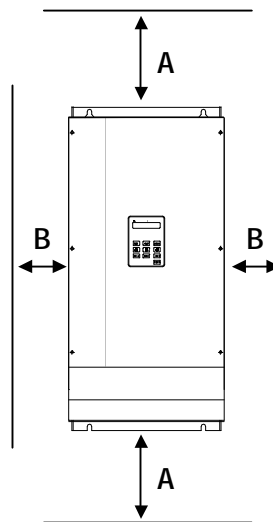

1.4 Dimensions

FRONT VIEW

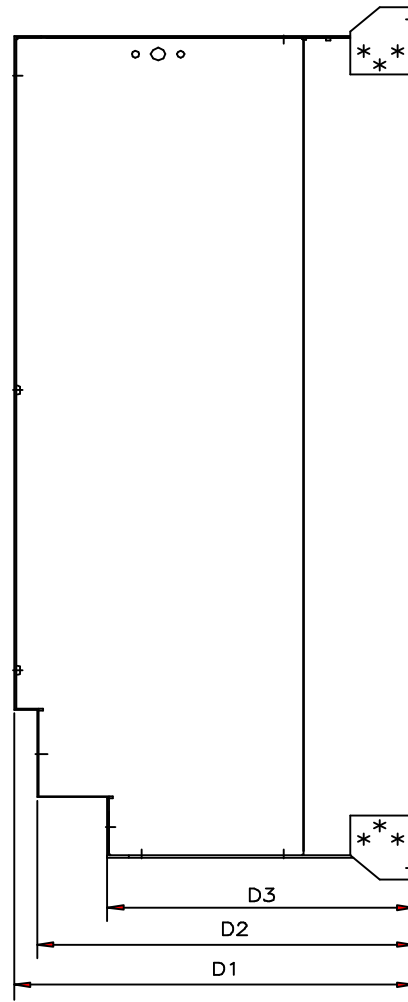
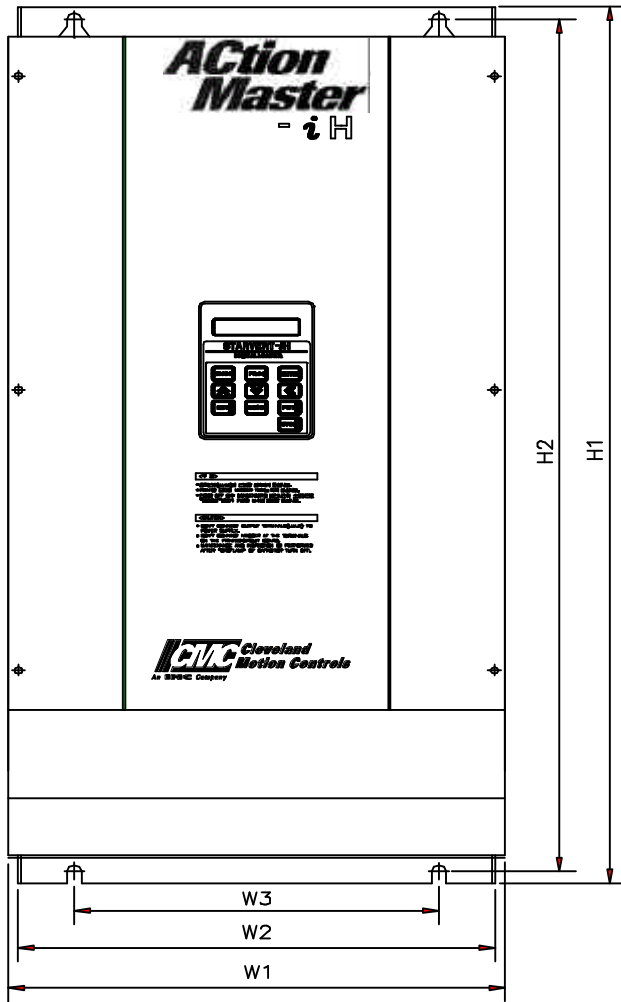

SIDE VIEW

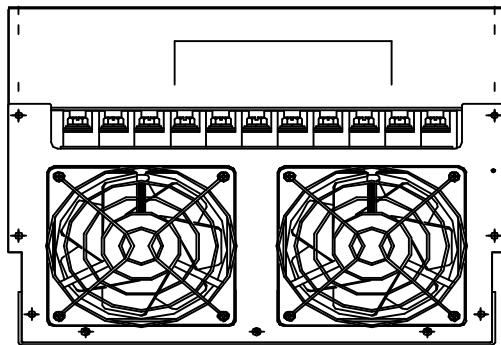

BOTTOM VIEW

Dimensions (millimeters)

Model No.	W1	W2	W3	H1	H2	D1	D2	D3
ACM-030H-2 40Hp – 230VAC	375	360	275	615	593.5	277.5	265.5	230.5
ACM-037H-2 50Hp – 230VAC	375	360	275	615	593.5	277.5	265.5	230.5
ACM-045H-2 60Hp – 230VAC	375	360	275	780	758.5	300.7	281.7	230.5
ACM-055H-2 75Hp – 230VAC	375	360	275	780	758.5	300.7	281.7	230.5
ACM-030H-4 40Hp – 460VAC	350	319.2	270	680	660	306.6	289.2	236.4
ACM-037H-4 50Hp – 460VAC	450	420	356.8	760	736.5	304.2	288.4	245.2
ACM-045H-4 60Hp – 460VAC	450	420	356.8	760	736.5	304.2	288.4	245.2
ACM-055H-4 75Hp – 460VAC	450	420	356.8	760	736.5	304.2	288.4	245.2
ACM-075H-4 100Hp – 460VAC	375	360	275	780	758.5	300.7	281.7	230.5
ACM-090H-4 125Hp – 460VAC	529	507	430	780	760	320.3	292	232
ACM-110H-4 150Hp – 460VAC	529	507	430	780	760	320.3	292	232
ACM-132H-4 175Hp – 460VAC	530	507	430	1000	980	352	331	253
ACM-160H-4 215Hp – 460VAC	530	507	430	1000	980	352	331	253
ACM-220H-4 300Hp – 460VAC	680	540	-	1002	968.5	400	-	-

Dimensions (inches)

Model No.	W1	W2	W3	H1	H2	D1	D2	D3
ACM-030H-2 40Hp – 230VAC	14.76	14.17	10.83	24.21	23.37	10.93	10.45	9.07
ACM-037H-2 50Hp – 230VAC	14.76	14.17	10.83	24.21	23.37	10.93	10.45	9.07
ACM-045H-2 60Hp – 230VAC	14.76	14.17	10.83	30.71	29.86	11.84	11.09	9.07
ACM-055H-2 75Hp – 230VAC	14.76	14.17	10.83	30.71	29.86	11.84	11.09	9.07
ACM-030H-4 40Hp – 460VAC	13.78	12.56	10.63	26.77	25.98	12.07	11.39	9.31
ACM-037H-4 50Hp – 460VAC	17.72	16.54	14.05	29.92	29.00	11.98	11.35	9.56
ACM-045H-4 60Hp – 460VAC	17.72	16.54	14.05	29.92	29.00	11.98	11.35	9.56
ACM-055H-4 75Hp – 460VAC	17.72	16.54	14.05	29.92	29.00	11.98	11.35	9.56
ACM-075H-4 100Hp – 460VAC	14.76	14.17	10.83	30.71	29.86	11.83	11.09	9.07
ACM-090H-4 125Hp – 460VAC	20.83	19.96	16.93	30.71	29.92	12.61	11.50	9.13
ACM-110H-4 150Hp – 460VAC	20.83	19.96	16.93	30.71	29.92	12.61	11.50	9.13
ACM-132H-4 175Hp – 460VAC	20.87	19.96	16.93	39.37	38.58	13.86	13.03	9.96
ACM-160H-4 215Hp – 460VAC	20.87	19.96	16.93	39.37	38.58	13.86	13.03	9.96
ACM-220H-4 300Hp – 460VAC	25.77	21.26	-	39.45	38.13	15.75	-	-

1.5 Basic Wiring

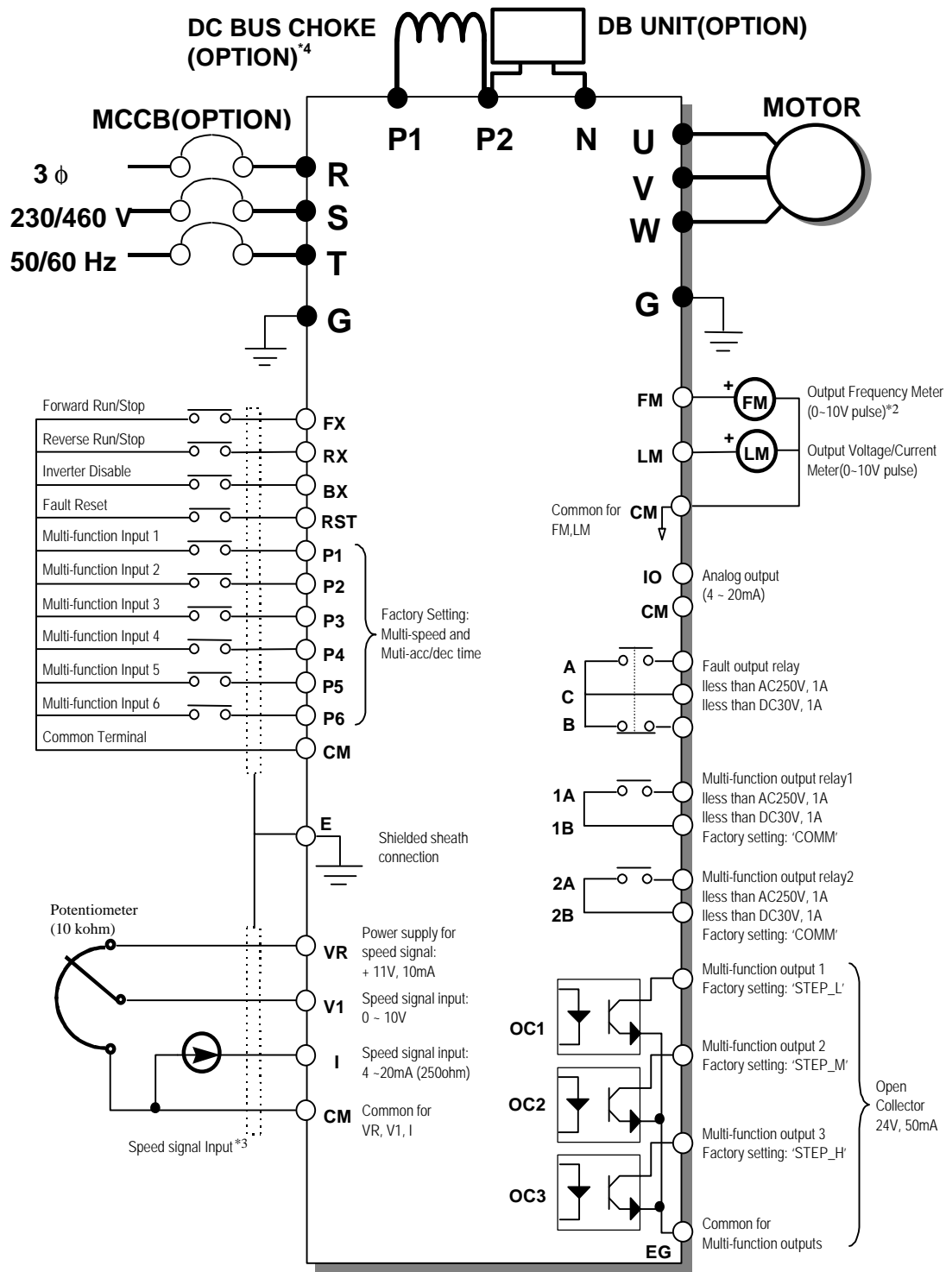

- Note) 1. ● display main circuit terminals, ○ display control circuit terminals.
 2. Analog output voltage can be set up to 12V.
 3. Analog speed command can be set by Voltage, Current and both of them.
 4. When installing the DC Reactor, the common busbar between P1 and P2 must be removed.

1.6 Control Terminals

1A	1B	2A	2B	OC1	OC2	CM	RST	FX	RX	BX	CM	VR	V1	V2	IO
A	C	B	EG	OC3	P1	P2	P3	P4	P5	P6	CM	I	FM	LM	CM

Symbols	Functions
V1	Speed Signal Input 1 (0 to +10V DC) (Wiper Connection Terminal)
V2	Speed Signal Input 2 (0 to +10V DC) (Wiper Connection Terminal)
VR	Voltage Power Supply for Speed Signal Terminal (+12VDC)
I	Current Speed Signal Input Terminal (4 to 20mA)
FM	Analog / Digital Frequency Output Terminal (For External Meters)
LM	Current / Voltage Output Terminal (For External Meters)
IO	Frequency Meter Analog Output (4 to 20mA)
CM	Common Terminal for [V1] [V2] [I] [FM] [LM] [IO]
FX	Forward Direction Command Terminal
RX	Reverse Direction Command Terminal
BX	Inverter Disable Command Terminal
RST	Fault Reset Terminal
P1	Multi-Function Input Terminal 1
P2	Multi-Function Input Terminal 2
P3	Multi-Function Input Terminal 3
P4	Multi-Function Input Terminal 4
P6	Multi-Function Input Terminal 5
CM	Common Terminal for [FX] [RX] [BX] [RST] [P1] [P2] [P3] [P4] [P5] [P6]
OC1	Multi-Function Output Terminal (open collector, 24V)
OC2	Multi-Function Output Terminal (open collector, 24V)
OC3	Multi-Function Output Terminal (open collector, 24V)
EG	Ground Terminal for [OC1] [OC2] [OC3]
1A, 1B	AUX. Relay (Multi-Function Output Terminal) (250VAC, 1A) or (30VDC, 1A)
2A, 2B	
A	Relay Output Terminal for Fault Signal (250VAC, 1A) or (30VDC, 1A)
B	
C	

1.7 Power Terminals

Type A Configuration: all 230VAC units (ACM-xxxH-2), and the following 460VAC units:
100 Hp (ACM-075H-4), **125 Hp** (ACM-090H-4), **150 Hp** (ACM-110H-4)



Type B Configuration: the following 460VAC units: **40 Hp** (ACM-030H-4), **50 Hp** (ACM-037H-4), **60 Hp** (ACM-045H-4), **75 Hp** (ACM-055H-4), **175 Hp** (ACM-132H-4)*, **215 Hp** (ACM-160H-4)*, **300 Hp** (ACM-220H-4)*.

* these models provide only one “G” terminal

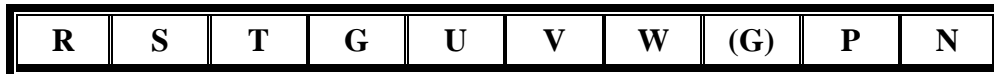

Symbols	Functions
R	AC Line Input (3 phase, 230V or 460V)
S	
T	
U	3-Phase Output Terminals to Motor
V	
W	
P1	DC Bus Choke Terminals (Positive DC Bus Terminal)
P2	
P	Positive DC Bus Terminal
N	Negative DC Bus Terminal
G	Chassis Ground

6.7.1 Type A Configuration

A dynamic brake or a DC bus choke or both a dynamic brake and a DC bus choke may be added to Series H- Series inverter that have a Type A configuration power terminal strip. Type A configuration power terminal strips have a jumper installed between P1 and P2 terminals by default. This jumper must be removed in order to install a DC bus choke.

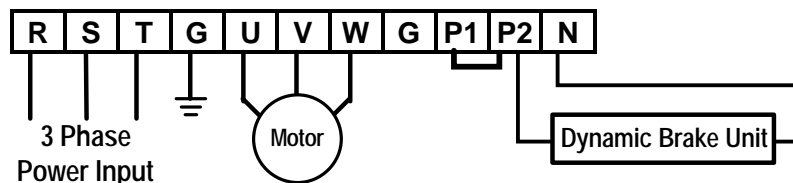

Figure 1 – Type A Dynamic Brake Unit Installation

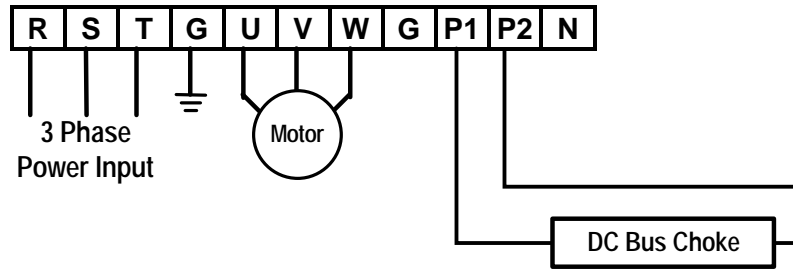

Figure 2 – Type A DC Bus Choke Installation

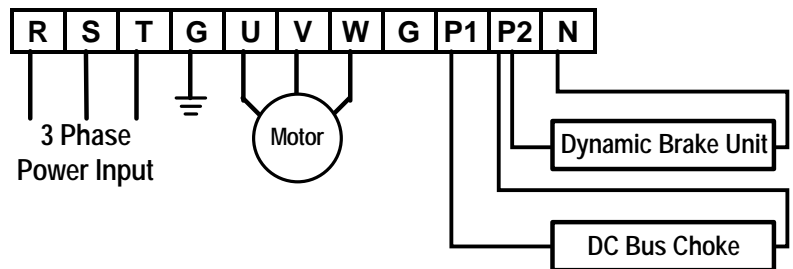

Figure 3 – Type A Dynamic Brake and DC Bus Choke Installation

6.7.2 Type B Configuration

A dynamic brake may be added to Series H-4 inverters that have a Type B Configuration power terminal strip.

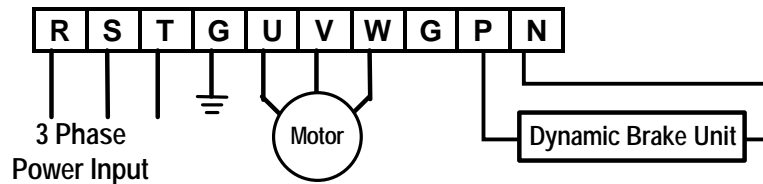

Figure 4 – Type B Dynamic Brake Installation

! WARNING !!

Normal stray capacitance between the inverter chassis and the power devices inside the inverter and AC line can provide a high impedance shock hazard. Do not apply power to the inverter if the inverter frame (Power terminal G) is not grounded.

CHAPTER 2 - OPERATION

2.1 Display

The Series H uses a 32-Character alphanumeric LCD display for its man-machine interface. All drive functions can be accessed by the keypad. The keypad also has upload and download capabilities. The keypad allows easy access to drive programming with parameter descriptions on the LCD display.

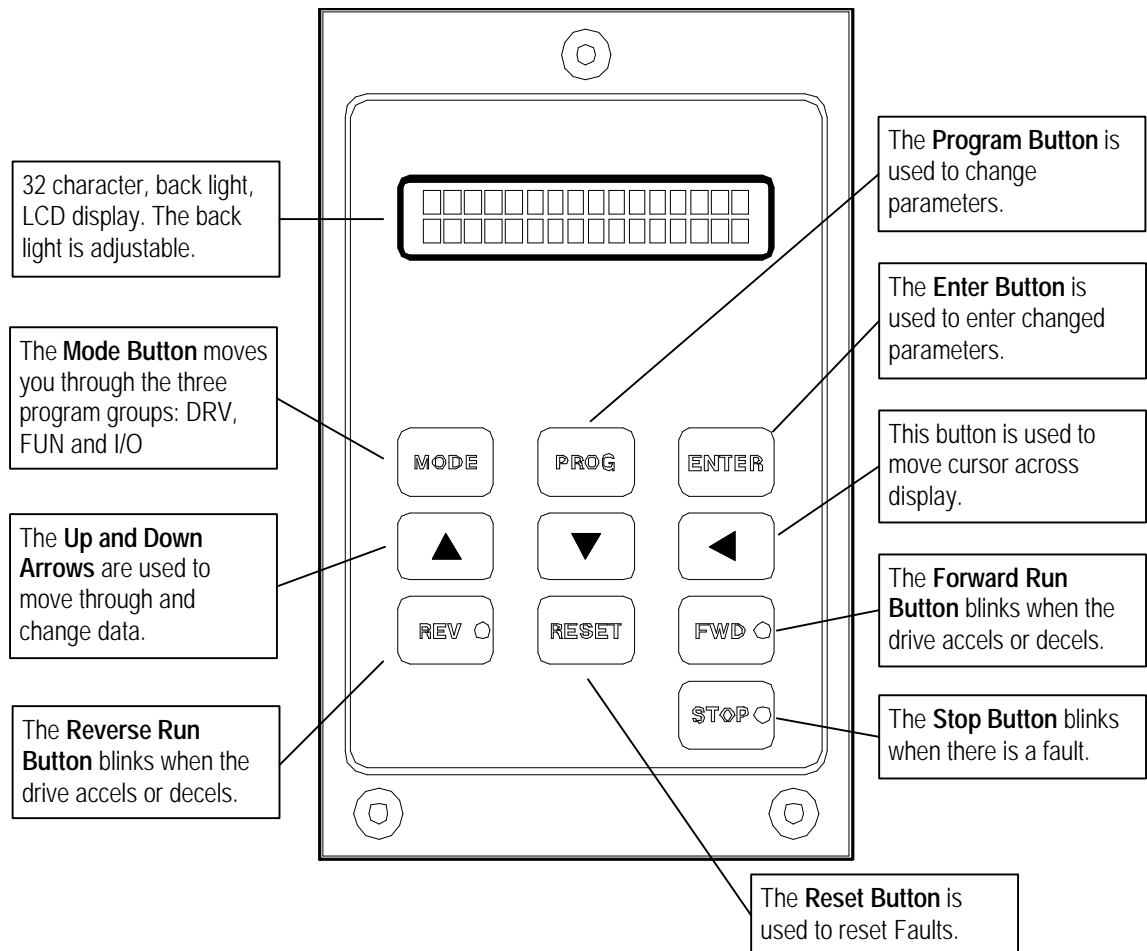

2.2 Alpha-numerical Display

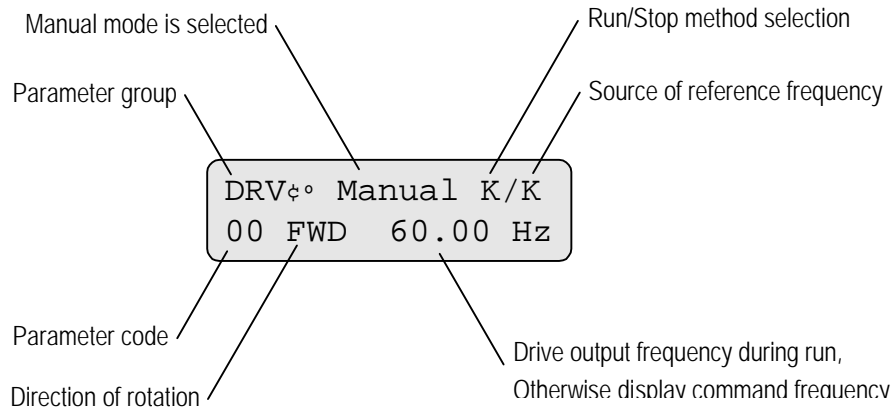











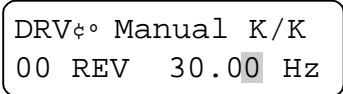
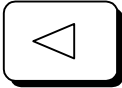
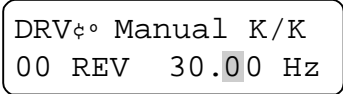

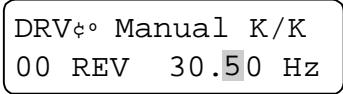
2.3 Operation

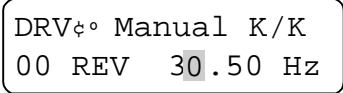
The are 3 parameter groups as shown below.

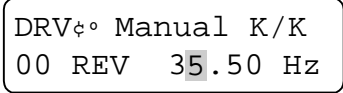
Group	LCD Control Panel	Description
Drive	DRV	Target frequency, acceleration (acc.) time / deceleration (dec.) time, speed, current, etc.
Function	FUN	Maximum frequency, manual torque boost, etc.
I/O	I/O	Multi input terminals, option, etc.

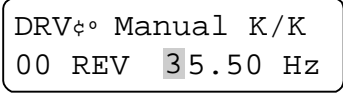
2.4 Procedure of setting data

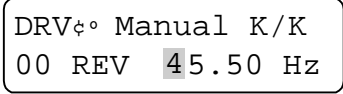
To change command frequency from 30.00Hz to 45.50Hz:

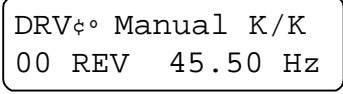
		Press PROG key and the cursor appears on the lowest digit.
		Press LEFT key once to move digit.
		Press UP key 5 times.
		Press LEFT key once to shift the cursor to next digit.
		Press UP key 5times.
		Press LEFT key once to shift the cursor to next digit.
		Press UP key once to make 4.
		Press ENTER key to store new value.

The same procedure is applied to all other parameters. While the drive is running, the output frequency can be changed to a new command frequency.

2.5 Parameter Navigation

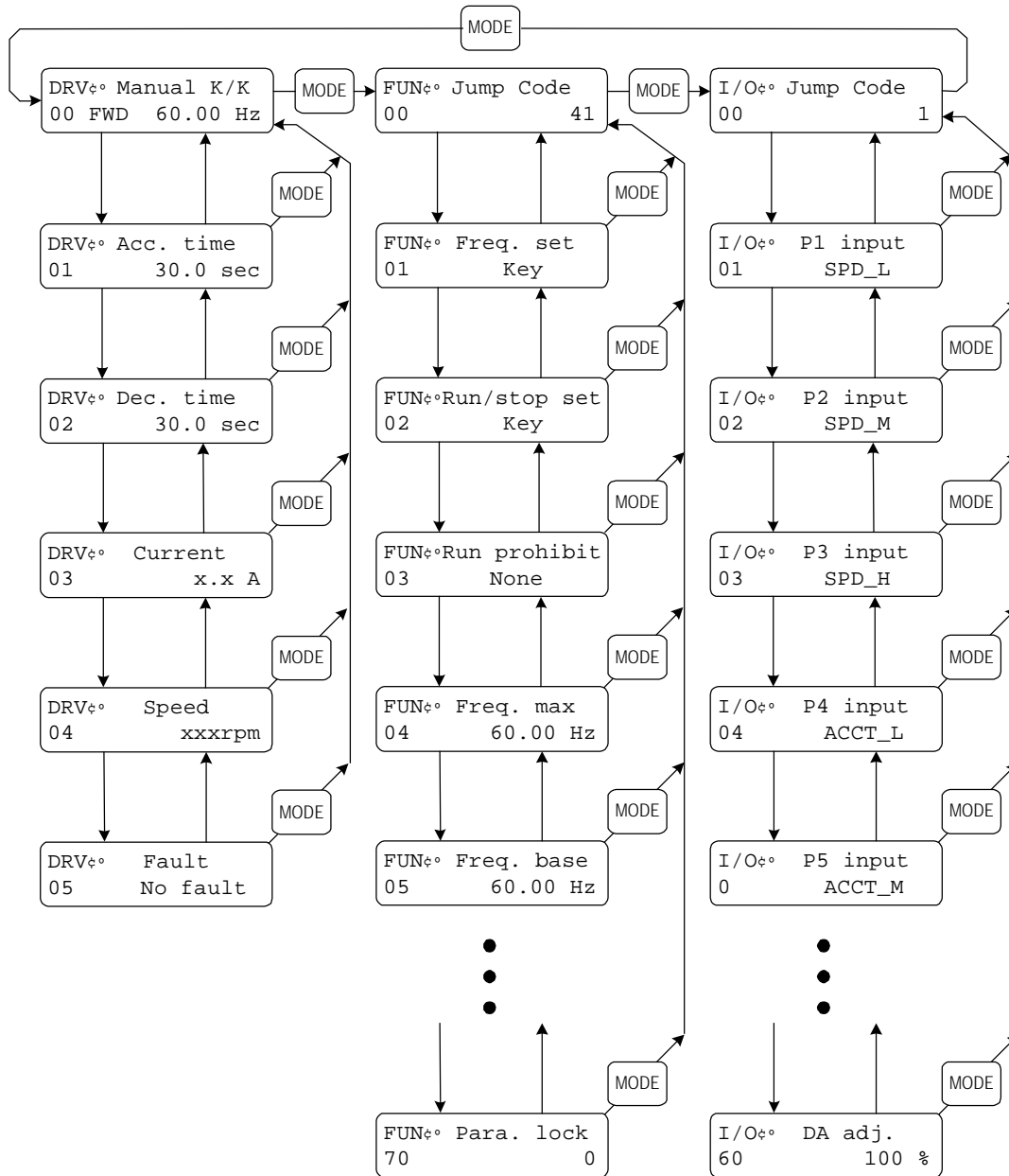

In any of the parameter groups, the user can jump to a specific parameter code by following these steps:

- Select a parameter group that requires a change.
- At the beginning of each program group the menu will read [Jump Code]. Press the [PROG] key. Enter the code number of each parameter needed to be changed then press [ENTER] key. There is no jump code for [Drive Group].

2.6 Control Method

The Series H has several operation methods as shown below.

Operation Method	Function	Function Setting
Operation using keypad	Run/Stop command and frequency are set only through the keypad.	FUN 01: Key FUN 02: Key
Operation using control terminals	Run/Stop is performed by closing FX or RX terminal. Frequency reference is set through V1 or I terminal.	FUN 01: Terminal FUN 02: Terminal-1
Operation using both keypad and control terminals	Run/Stop is performed by the keypad. Frequency reference is set through the V1 or I terminal.	FUN 01: Terminal FUN 02: Key
	Run/Stop is performed by either the FX or RX terminal. Frequency reference is set through the keypad.	FUN 01: Key FUN 02: Terminal-1
Option	Operation using RS485 communication between inverter and computer.	FUN 01: Key FUN 02: RS485/PLC I/O 48: RS485
	Operation using PLC communication between inverter and PLC.	FUN 01: Key FUN 02: RS485/PLC I/O 48: PLC

CHAPTER 3 - QUICK START UP

3.1 Easy Start Up (Drive Control through Keypad)

1. Perform power connection as shown in Section 1.7.

2. If the message of DRV 00 is 'Manual K/K', go to step 11.

```
DRVϕ° Manual K/K
00 FWD  0.00 Hz
```

3. Press the [MODE] key to display FUN GROUP.

```
MODE FUNϕ° Jump code
00 41
```

4. Press the Up-arrow key to display FUN 01.

```
△ FUNϕ° Freq. set
01 Terminal
```

5. Press the [PROG] key to enter into the program mode.

```
PROG FUNϕ° Freq. set
01 Terminal
```

6. Using arrow keys, select 'Key', then press the [ENTER] key.

```
△ FUNϕ° Freq. set
01 Key
```

```
ENTER
```

7. Press Up-arrow key to display FUN 02.

```
△ FUNϕ°Run/stop set
02 Terminal-1
```

8. Press [PROG] key to enter into the program mode.

```
PROG FUNϕ°Run/stop set
02 Terminal-1
```

9. Using arrow keys, select 'Key', then press the [ENTER] key.

```
△ FUNϕ°Run/stop set
02 Key
```

```
ENTER
```

10. Press the [MODE] key repeatedly until DRV 00 is displayed.

```
MODE DRVϕ° Manual K/K
00 FWD  0.00 Hz
```

Chapter 3 - Quick Start Up

11. Set the frequency reference by pressing the [PROG] key. Using Arrow keys, change the data to 5.00 Hz. Press the [ENTER] key.

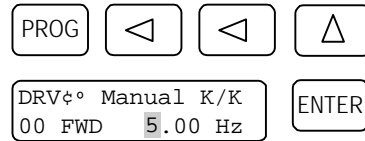

12. Press Up-arrow key to display DRV 01. Change the acceleration time by pressing the [PROG], arrow and [ENTER] keys.

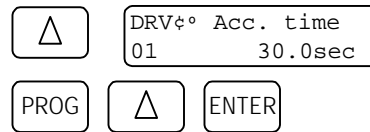

13. Press the UP-arrow key to display DRV 02. Change the Deceleration time by pressing the [PROG], arrow and [ENTER] keys.

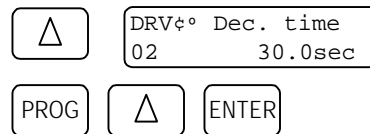

14. To run the motor in the forward direction, press the [FWD] key.



15. To run the motor in the reverse direction, press the [REV] key.



16. To stop the motor, press the [STOP] key.



3.2 Control Terminal Operation – External Start, Stop and Speed Reference

1. Confirm 'Manual T/T' in DRV 00.

DRV ϕ	Manual T/T
00 FWD	60.00 Hz

2. If different, as in section 3.1 of this chapter, select 'Terminal' in FUN 01 and 'Terminal-1' or Terminal-2' in FUN 02.

FUN ϕ	Freq. set
01	Terminal

FUN ϕ	Run/stop set
02	Terminal-1

3. Install a potentiometer on terminals V1, VR and CM as shown right. Select 'V1' in FUN 20 to control the speed by potentiometer alone.

FUN ϕ	V-I mode
20	I

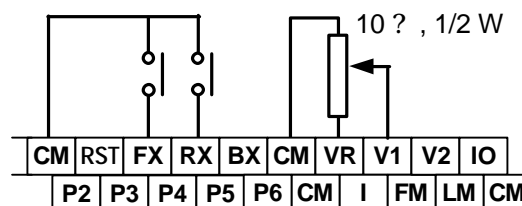

4. Set a frequency reference using the potentiometer. Make sure to observe the set value in DRV 00.

5. When a '4 - 20mA' current source is used as the frequency reference, use terminal I and CM. Select 'I' in FUN 20 to control the speed by the current source alone.

FUN ϕ	V-I mode
20	I

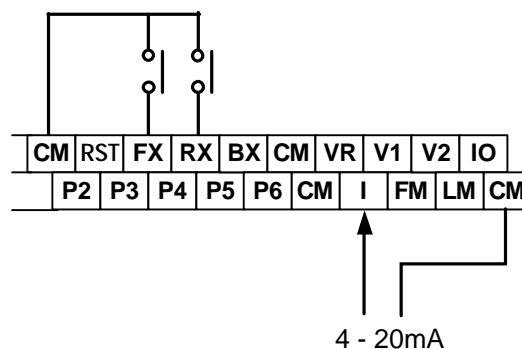

6. To run the motor in the forward direction, close the [FX] terminal to the [CM] terminal.
7. To run the motor in the reverse direction, close the [RX] terminal to the [CM] terminal.

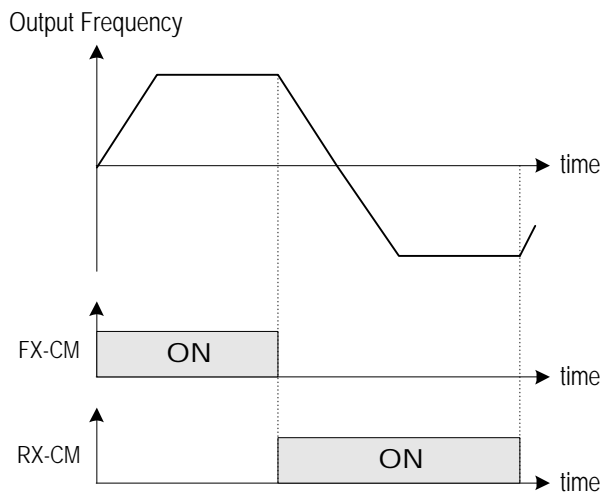

[FUN 02 - 'Terminal-1' Operation]

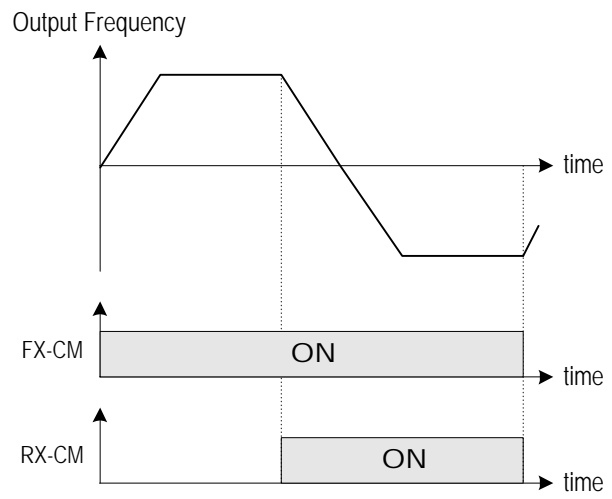

[FUN 02 - 'Terminal-2' Operation]

3.3 Operation with both Control Terminals and Keypad

6.3.1 Frequency set by External Source / Run/stop set by Keypad

1. Confirm 'Manual K/T' in DRV 00.

DRV ϕ	Manual K/T
00	FWD 60.00 Hz

2. If different, as in section 3.1 of this chapter, select 'Terminal' in FUN 01 and 'Key' in FUN 02.

FUN ϕ	Freq. set
01	Terminal

FUN ϕ	Run/stop set
02	Key

3. Install a potentiometer to terminals V1, VR and CM. Select 'V1' in FUN 20 to control the speed by the potentiometer alone.

FUN ϕ	V-I mode
20	V1

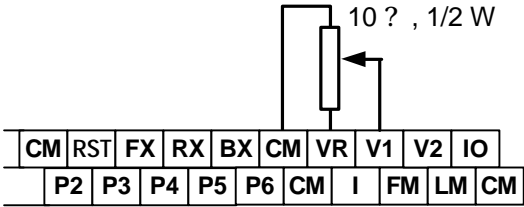

4. Set a frequency reference using the potentiometer. Make sure to observe the set value in DRV 00.

5. When a '4 - 20mA' current source is used as the frequency reference, use terminals I and CM. Select 'I' in FUN 20 to control the speed by the current source alone.

FUN ϕ	V-I mode
20	I

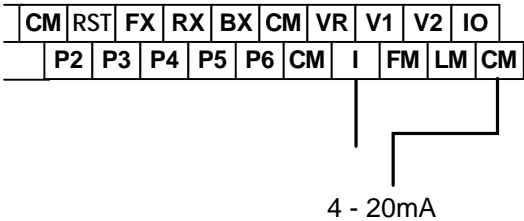

6. To run the motor in the forward direction, press the [FWD] key.

7. To run the motor in the reverse direction, press the [REV] key.

8. To stop the motor, press the [STOP] key.

6.3.2 Frequency set by Keypad / Run/stop set by External Source

1. Confirm 'Manual T/K' in DRV 00.

DRV ϕ ° Manual T/K
00 FWD 60.00 Hz

2. If different, as in section 3.1 of this chapter, select 'Key' in FUN 01 and 'Terminal-1' or Terminal-2' in FUN 02.

FUN ϕ ° Freq. set
01 Key

FUN ϕ °Run/stop set
02 Terminal-1

3. Set a frequency reference in DRV 00.

DRV ϕ ° Manual T/K
00 FWD 60.00 Hz

PROG	Δ	ENTER
------	----------	-------

4. To run the motor in the forward direction, close the [FX] terminal to the [CM] terminal.

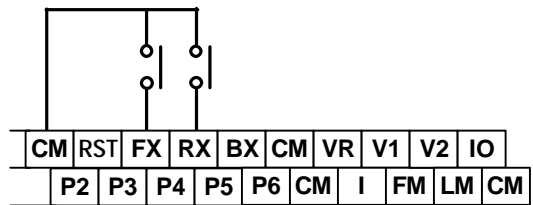

5. To run the motor in the forward direction, close the [RX] terminal to the [CM] terminal.

CHAPTER 4 - PARAMETER LIST

4.1 Drive Group

Code [DRV]	Description Drive Group	Keypad Display	Setting Range	Units	Factory Default	Adjustable during run	Page
00	Output Frequency (during run), Reference Frequency(during stop)	Manual K/K	0 to 400	0.01	0Hz	Yes	36
01	Acceleration Time	Acc. Time	0 to 6000	0.1	30sec	Yes	36
02	Deceleration Time	Dec. time	0 to 6000	0.1	60sec	Yes	36
03	Output Current	Current	-	-	-	-	36
04	Output Speed	Speed	-	-	-	-	36
05	Fault display	Fault	-	-	-	-	37

4.2 Function Group

Code [FUN]	Description Function Group	Keypad Display	Setting Range	Units	Factory Default	Adjustable during run	Page
00	Jump to desired code #	Jump Code	1 to 70	1	41	Yes	38
01	Frequency Reference Source selection	Freq. Set	Key, Terminal	-	Key	No	38
02	Run / Stop Control Source selection	Run/stop set	Key, Terminal-1, Terminal-2, RS485/PLC	-	Key	No	38
03	Run Prevention	Run prohibit	None, FWD disable, REV disable	-	None	No	39
04	Maximum Frequency Output set point	Freq. Max	40 to 400	0.01	60Hz	No	39
05	Base Frequency	Freq. Base	40 to FUN 04	0.01	60Hz	No	39
06	Starting Frequency	Freq. Start	0.5 to 5	0.01	0.5Hz	No	39
07	Hold time for Starting Frequency	Hold time	0 to 10	0.1	0sec	Yes	40
08	Volts / Hz Pattern	V/F pattern	Linear, 1.5(Squared), User, Auto	-	Linear	No	40
09	Torque Boost in Forward direction	Fwd boost	0 to 20	1	2%	Yes	41
10	Torque Boost in Reverse direction	Rev boost	0 to 20	1	2%	Yes	41
11	Acceleration pattern	Acc. Pattern	Linear, S-Curve, U-curve	-	Linear	No	42

Chapter 4 - Parameter List

Code [FUN]	Description Function Group	Keypad Display	Setting Range	Units	Factory Default	Adjustable during run	Page
12	Deceleration pattern	Dec. pattern	Linear, S-Curve, U-Curve	-	Linear	No	42
13	Output Voltage Adjustment	Volt control	40 to 110	1	100%	No	43
14	Energy Save Level	Energy save	30 to 100	1	100%	Yes	43
15	Stop Pattern selection	Stop mode	Decel, DCBR, Free Run	-	Decel	No	43
16	User V/F pattern - Frequency 1	User-1f	0 to 30	0.01	10Hz	No	44
17	User V/F pattern - Voltage 1	User-1v	0 to 50	1	15%	No	44
18	User V/F pattern - Frequency 2	User-2f	FUN 16 to FUN 04	1	30Hz	No	44
19	User V/F pattern - Voltage 2	User-2v	FUN 17 to 100	1	50%	No	44
20	Analog Speed Reference selection	V-I mode	V1, I, V1 + I, V2	-	V1	No	45
21	Analog Speed input Filter Gain	Filter gain	1 to 100	1	25%	Yes	46
22	Analog Speed input Scaling	Analog gain	50 to 250	1	100%	Yes	46
23	Analog Speed input Bias	Analog bias	0 to 100%	1	0%	Yes	46
24	Analog Speed input Direction	Analog dir	Direct, Invert	-	Direct	Yes	46
25	Frequency Limit selection	Freq. limit	No, Yes	-	No	No	47
26	High Limit Frequency	F-limit high	0 to FUN 04	0.01	60Hz	No	47
27	Low Limit Frequency	F-limit low	0 to FUN 26	0.01	0Hz	No	47
28	Frequency Jump selection	Freq. jump	No, Yes	-	No	No	48
29	Jump Frequency 1	Freq-jump 1f	0 to FUN 04	0.01	10Hz	No	48
30	Jump Frequency 2	Freq-jump 2f	0 to FUN 04	0.01	20Hz	No	48
31	Jump Frequency 3	Freq-jump 3f	0 to FUN 04	0.01	30Hz	No	48
32	Bandwidth of Jump Frequency	Freq. band	0 to 30	0.01	5Hz	No	48
33	DC Injection Braking Frequency	DC-br freq	0 to 60	0.01	0.5Hz	Yes	49
34	DC Injection Braking On-Delay Time	DC-br block	0.5 to 5	0.1	2sec	Yes	49
35	DC Injection Braking Time	DC-br time	0.1 to 250	0.1	0.5sec	Yes	49
36	DC Injection Braking Voltage	DC-br value	1 to 20	1	1%	Yes	49
37	Slip Compensation selection	Slip compen.	No, Yes	-	No	Yes	50
38	Rated Slip of Motor	Rated slip	0 to 5	0.01	0Hz	Yes	50

Code [FUN]	Description Function Group	Keypad Display	Setting Range	Units	Factory Default	Adjustable during run	Page
39	Rated Current of Motor	M-rated cur.	0.1 to 999	0.1	122A ¹	Yes	50
40	No Load Current of Motor	No-load cur.	0.1 to 300	0.1	0.1A	Yes	50
41	Inverter Capacity NOTE: See Page 31 for cross-reference of old Part Numbers to new Part Numbers and HP / Voltage Capacity of Inverter.	Inv Capacity	SV030Series H-2 SV037Series H-2 SV315Series H-4 SV375Series H-4	-	SV030 Series H-2 ²	No	51
42	Number of Auto Restart attempt	Retry number	0 to 10	1	0	Yes	51
43	Auto Restart waiting time	Retry time	0 to 10	1	1sec	Yes	51
44	Fault Output Relay Mode Selection	Relay mode	Retry 0, All Trips, LV+Retry 0, LV+All Trips	-	Retry 0	Yes	51
45	Stall Prevention Mode selection	Stall mode	None, Acc, Steady, Acc+Steady, Dec, Acc+Dec, Dec+Steady, Acc+Dec+ Steady	-	None	Yes	52
46	Stall Prevention Level	Stall level	30 to 150	1	150%	Yes	52
47	Overload Warning Level	OL level	30 to 150	1	150%	Yes	53
48	Overload Warning Hold Time	OL time	1 to 30	1	10sec	Yes	53
49	Overcurrent Limit Level	OC lim level	30 to 200	1	160%	Yes	54
50	Overcurrent Limit Time	OC lim. Time	0 to 60	0.1	60sec	Yes	54
51	Electronic Thermal selection	ETH select	No, Yes	-	No	Yes	54
52	Electronic Thermal Level	ETH level	30 to 150	1	150%	Yes	54
53	Electronic Thermal Characteristic (motor type) selection	Motor type	General, Special	-	General	Yes	54

¹ Default value will depend on the inverter capacity.

² FUN 41 is set at its inverter capacity before shipping outside. However, inverter loses its capacity after parameter initialization in FUN 69. If the parameters are initialized, be sure to re-set the inverter capacity to the right capacity.

Chapter 4 - Parameter List

Code [FUN]	Description Function Group	Keypad Display	Setting Range	Units	Factory Default	Adjustable during run	Page
54	Number of motor pole	Pole number	2 to 12	1	4	Yes	55
55	IPF (Instant Power Failure) Restart selection	IPF select	No, Yes	-	No	Yes	55
56	Acceleration time during Speed - Search	SS acc. time	0.1 to 600	0.1	5sec	Yes	55
57	Deceleration time during Speed- Search	SS dec. Time	0.1 to 600	0.1	10sec	Yes	55
58	Speed-Search Gain	SS gain	0 to 200	1	100%	Yes	55
59	Restart after Fault Reset	RST-restart	No, Yes	-	No	Yes	56
60	Restart after Power Up sequence	Power on st	No, Yes	-	No	Yes	57
61	Carrier Frequency	Carrier Freq	2 to 10	1	6kHz ³	No	57
62	PI Control selection	PI-control	No, Yes	-	No	No	57
63	Proportional Gain	P-gain	1 to 30000	1	10	Yes	57
64	Integral Gain	I-gain	1 to 30000	1	50	Yes	57
65	PI Feedback Offset	PI-FB Offset	0 to 50	1	0	Yes	57
66	PI Feedback Scale	PI-FB Scale	1 to 250	1	100	Yes	57
67	Read Parameters in to Keypad	Para. Read	No,	-	No	No	58

³ Carrier Frequency according to the Inverter Capacity

Inverter	Setting Range	Factory Default	Inverter	Setting Range	Factory Default
ACM-030H-2 40hp/230v	2 to 10	6kHz	ACM-075H-4 100hp/460v	2 to 7	6kHz
ACM-037H-2 50hp/230v	2 to 10	6kHz	ACM-090H-4 125hp/460v	2 to 6	6kHz
ACM-045H-2 60hp/230v	2 to 8	6kHz	ACM-110H-4 150hp/460v	2 to 6	6kHz
ACM-055H-2 75hp/230v	2 to 8	6kHz	ACM-132H-4 175hp/460v	2 to 5	5kHz
ACM-030H-4 40hp/460v	2 to 10	6kHz	ACM-160H-4 215hp/460v	2 to 4	4kHz
ACM-037H-4 50hp/460v	2 to 10	6kHz	ACM-220H-4 300hp/460v	2 to 4	4kHz
ACM-045H-4 60hp/460v	2 to 8	6kHz			
ACM-055H-4 75hp/460v	2 to 8	6kHz			

Code [FUN]	Description Function Group	Keypad Display	Setting Range	Units	Factory Default	Adjustable during run	Page
	from Drive		Yes				
68	Write Parameters to Drive from Keypad	Para. Write	No, Yes	-	No	No	58
69	Initialize all parameters to Factory Default Values	Para. Init	No, Yes	-	No	No	59
70	Parameter write protection	Para. Lock	0 to 255	1	0	Yes	59

CROSS REFERENCE for Function 41 setting (Inverter Capacity):

Old Part Number	CMC Part Number	CMC Model No.	Horsepower (CT)
SV030 Series H-2	X44-33393 Ser H-2	ACM-030H-2	40 HP, 230 VAC
SV037 Series H-2	X44-33394 Ser H-2	ACM-037H-2	50 HP, 230 VAC
SV045 Series H-2	X44-33395 Ser H-2	ACM-045H-2	60 HP, 230 VAC
SV055 Series H-2	X44-33396 Ser H-2	ACM-055H-2	75 HP, 230 VAC
SV030 Series H-4	X44-33397 Ser H-4	ACM-030H-4	40 HP, 460 VAC
SV037 Series H-4	X44-33398 Ser H-4	ACM-037H-4	50 HP, 460 VAC
SV045 Series H-4	X44-33399 Ser H-4	ACM-045H-4	60 HP, 460 VAC
SV055 Series H-4	X44-33400 Ser H-4	ACM-055H-4	75 HP, 460 VAC
SV075 Series H-4	X44-33401 Ser H-4	ACM-075H-4	100 HP, 460 VAC
SV090 Series H-4	X44-33402 Ser H-4	ACM-090H-4	125 HP, 460 VAC
SV110 Series H-4	X44-33403 Ser H-4	ACM-110H-4	150 HP, 460 VAC
SV132 Series H-4	X44-33404 Ser H-4	ACM-132H-4	175 HP, 460 VAC
SV160 Series H-4	X44-33405 Ser H-4	ACM-160H-4	215 HP, 460 VAC
SV220 Series H-4	X44-33406 Ser H-4	ACM-220H-4	300 HP, 460 VAC

Chapter 4 - Parameter List

I/O Group

Code [I/O]	Description Function Group	Keypad Display	Setting Range	Units	Factory Default	Adjustable during run	Page
00	Jump to desired code #	Jump Code	1 to 60	1	1	Yes	60
01	Multi-function Input 1 (P1 term.)	P1 Input	SPD_L, SPD_M, SPD_H,	-	SPD_L	No	60
02	Multi-function Input 2 (P2 term.)	P2 Input	JOG, ACCT_L, ACCT_M,	-	SPD_M	No	60
03	Multi-function Input 3 (P3 term.)	P3 Input	ACCT_H, UP, DOWN,	-	SPD_H	No	60
04	Multi-function Input 4 (P4 term.)	P4 Input	HOLD, OPT_MAN, COMM_CONN,	-	ACCT_L	No	60
05	Multi-function Input 5 (P5 term.)	P5 Input	EXT_DCBR, EXT_TRIP	-	ACCT_M	No	60
06	Multi-function Input 6 (P6 term.)	P6 Input		-	ACCT_H	No	60
07	Multi-function Output 1 (OC1 terminal)	OC1 Output	FST_LO, FST_HI, FDT_HI,	-	STEP_L	No	63
08	Multi-function Output 2 (OC2 terminal)	OC2 Output	FDT_PULSE, FDT_BAND,	-	STEP_M	No	63
09	Multi-function Output 3 (OC3 terminal)	OC3 Output	OL, STALL, LV,	-	STEP_H	No	63
10	Multi-function Output 4 (Aux.1 Relay term.)	AUX1 output	RUN, COMM,	-	COMM	No	63
11	Multi-function Output 5 (Aux. 2 Relay term.)	AUX2 output	STEP_L, STEP_M, STEP_H	-	COMM	No	63
12	Jog Frequency	Jog freq.	0 to FUN 04	0.01	30Hz	Yes	66
13	Step Frequency 1	Step freq-1	0 to FUN 04	0.01	10Hz	Yes	67
14	Step Frequency 2	Step freq-2	0 to FUN 04	0.01	20Hz	Yes	67
15	Step Frequency 3	Step freq-3	0 to FUN 04	0.01	30Hz	Yes	67
16	Step Frequency 4	Step freq-4	0 to FUN 04	0.01	40Hz	Yes	67
17	Step Frequency 5	Step freq-5	0 to FUN 04	0.01	50Hz	Yes	67
18	Step Frequency 6	Step freq-6	0 to FUN 04	0.01	46Hz	Yes	67
19	Step Frequency 7	Step freq-7	0 to FUN 04	0.01	37Hz	Yes	67
20	Acceleration time 1	Acc time-1	0 to 6000	0.1	1sec	Yes	67

Code [I/O]	Description Function Group	Keypad Display	Setting Range	Units	Factory Default	Adjustable during run	Page
21	Deceleration time 1	Dec time-1	0 to 6000	0.1	1sec	Yes	67
22	Acceleration time 2	Acc time-2	0 to 6000	0.1	2sec	Yes	67
23	Deceleration time 2	Dec time-2	0 to 6000	0.1	2sec	Yes	67
24	Acceleration time 3	Acc time-3	0 to 6000	0.1	3sec	Yes	67
25	Deceleration time 3	Dec time-3	0 to 6000	0.1	3sec	Yes	67
26	Acceleration time 4	Acc time-4	0 to 6000	0.1	4sec	Yes	67
27	Deceleration time 4	Dec time-4	0 to 6000	0.1	4sec	Yes	67
28	Acceleration time 5	Acc time-5	0 to 6000	0.1	5sec	Yes	67
29	Deceleration time 5	Dec time-5	0 to 6000	0.1	5sec	Yes	67
30	Acceleration time 6	Acc time-6	0 to 6000	0.1	6sec	Yes	67
31	Deceleration time 6	Dec time-6	0 to 6000	0.1	6sec	Yes	67
32	Acceleration time 7	Acc time-7	0 to 6000	0.1	7sec	Yes	67
33	Deceleration time 7	Dec time-7	0 to 6000	0.1	7sec	Yes	67
34	Output Voltage / Current Meter Select	Analog meter	Voltage, Current	-	voltage	Yes	67
35	Output Voltage / Current Meter Adjustment (15V Pulse)	Analog adj.	0 to 120	1	100%	Yes	67
36	FM Meter Output Adjustment (15V Pulse)	FM adj.	0 to 120	1	100%	Yes	68
37	IO Meter Output Adjustment (4 to 20mA)	DAC adj.	0 to 120	1	100%	Yes	68
38	Frequency Steady Level	FST-freq.	0 to FUN 04	0.01	0.5Hz	No	68
39	Frequency Detection Level	FDT-freq.	0 to FUN 04	0.01	60Hz	No	68
40	Frequency Detection Bandwidth	FDT-band	0 to 30	0.01	1Hz	No	68
41	Multiplier Constant for Speed Display in 'DRV 04'	Mul. Factor	0 to 999	1	100	Yes	69
42	Divider Constant for Speed Display in 'DRV 04'	Div. factor	1 to 999	1	100	Yes	69
43	Status of Input Terminals	Ter. Input	-	-	-	-	69
44	Status of Output Terminals	Ter. Output	-	-	-	-	69
45	Software Version	S/W version	-	-	-	-	69
46	Fault History 1	Last fault 1	Fault Status, Freq. at Fault	-	-	Yes	69
47	Fault History 2	Last fault 2		-	-	Yes	69
48	Option 1 selection	Option 1	None, RS485, PG, DI/DA, PLC, CAN	-	None	No	70
49	Option 2 selection	Option 2		-	None	No	70

Chapter 4 - Parameter List

Code [I/O]	Description Function Group	Keypad Display	Setting Range	Units	Factory Default	Adjustable during run	Page
50 ⁴	Inverter number for Option	Inv. Number	1 to 32	1	1	Yes	71
51 ⁴	Baud rate for Option	Baud-rate	1200, 2400, 4800, 9600, 19200	-	9600 BPS	Yes	71
52 ⁴	Communication Timeout	Comm. Timeout	0 to 60	0.1	10sec	Yes	71
53 ⁴	PG Slip Frequency for PG Option	PG Slip Freq	0 to 10	0.01	5Hz	Yes	71
54 ⁴	PG-P Gain for PG Option	PG. P-Gain	0 to 225	1	1	Yes	71
55 ⁴	PG-I Gain for PG Option	PG. I-Gain	0 to 225	1	1	Yes	71
56 ⁴	PG-Filter Gain for PG Option	PG. F-Gain	0 to 225	1	100	Yes	72
57 ⁴	Encoder Selection for PG Option	Enc pulse	100, 500, 512, 1000, 1024, 2000, 2048, 4000	-	512 Pulse	Yes	72
58 ⁴	Digital Input for DI/DA Option	DI Mode	None, Freq. 1, Freq. 2	-	Freq.1	Yes	72
59 ⁴	Analog Output for DI/DA Option	DA Mode	Freq., Voltage, Current	-	Freq.	Yes	72
60 ⁴	Analog Output Adjustment	DA adj.	80 to 120	1	100%	Yes	72

⁴ Option related parameters - please refer to option manual.

CHAPTER 5 - PARAMETER DESCRIPTION

5.1 Drive Group

DRV 00: Reference Frequency

Display: Output frequency during run or Reference frequency during stop

DRV ϕ Manual K/K
00 FWD 60.00 Hz

Setting Range: 0 to FUN 04 [Freq. max]

Description:

- When the drive is stopped, the keypad will read [Reference Frequency]. This is the target frequency.
- When the drive is running, the keypad will read [Output Frequency]. This is the actual output frequency.

The reference frequency can be set by the keypad or analog input (Speed pot or 4 to 20mA). The factory default is keypad. To change the reference frequency from keypad to terminal, go to FUN 01.

DRV 01: Acceleration Time DRV 02: Deceleration Time

Display:

DRV ϕ Acc. Time
01 30.0 sec

DRV ϕ Dec. Time
02 60.0 sec

Setting Range: 0 to 6000sec

Description:

Acceleration time means the time it takes the drive to go to FUN 04 [Freq. max] from 0 Hz. Deceleration time means the time to 0Hz from FUN 04 [Freq. max].

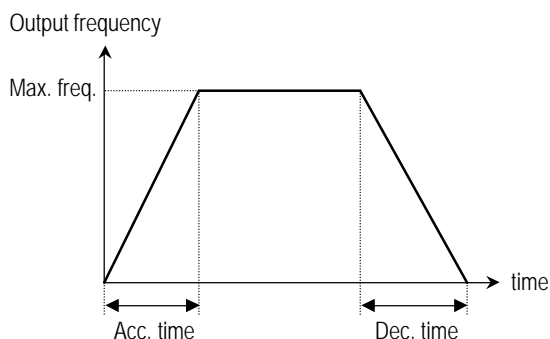

In case of fast acceleration or deceleration are required, set the Acc. time and Dec. time shorter.

DRV 03: Output Current

Display:

DRV ϕ Current
03 10.0 A

Description:

Displays the RMS value of the inverter output current when the drive is running.

DRV 04: Output Speed

Display:

DRV ϕ Speed
04 1800 rpm

Description:

Displays the motor speed in RPM. Line speed of motor (m/min.) can be calculated by the FUN 54 [Pole number] and I/O 41 [Mul. Factor], I/O 42 [Div. Factor].

[RESET] key or RST terminal. Unlatched faults are cleared when the fault condition disappeared.

DRV 05: Fault display

Display:

DRV ϕ °	Fault
05	No Fault

Description:

Displays the status of fault. The output of the inverter is turned off when a trip occurred. The condition at the time of the fault can be examined through [Motor current] and [Output frequency]. The [STOP] LED blinks when a fault has occurred. Below table shows the fault item.

Fault	Display	Remark
Over current	OC Trip	Latch
Over voltage	OV Trip	Latch
External trip	EXT Trip	Latch
Inverter disabled	BX	Unlatch
Low voltage	LV Trip	Unlatch
Fuse blown	Fuse Open	Latch
Ground fault	GF Trip	Latch
High temperature inside inverter	Over Heat	Latch
Electronic thermal protected	ETH	Latch
Over current limit time out	OC Limit	Latch
Short through trip	SC Trip ⁵	Latch

■ **Note:** Latched faults can be cleared by either

⁵ Available over 220kW inverters. To reset this fault, the main input power should be disconnected.

5.2 Function Group

FUN 00: Jump to desired code

Display:

```
FUN# Jump Code
00          41
```

Setting Range: 0 to 70

Description:

Any program code can be jumped to directly by entering the desired program code number.

Application:

Jump to any function parameter code by pressing the [PROG] key, scrolling to desired code with [Arrow] keys and then pressing the [ENTER] key.

FUN 01: Frequency Reference Source selection

Display:

```
FUN# Freq. set
01      Key
```

Setting Range: Key, Terminal

Description:

Key: The target frequency is controlled and set up using the keypad in Drive Group – DRV 00 [Manual K/K].

Terminal: The target frequency is controlled and set up using the terminal strip with an analog speed pot (10V DC) or a 4 to 20 mA current signal.

■ Related Parameters: FUN 20 – 24

FUN 02: Run/Stop Source selection

Display:

```
FUN# Run/stop set
02      Key
```

Setting Range: Key, Terminal-1, Terminal-2, RS485/PLC

Description:

Key: Run/stop is controlled by keypad.

Terminal-1: Run/stop is controlled by control terminals FX, RX and CM.

FX-CM: Forward run and stop control

RX-CM: Reverse run and stop control

Terminal-2: Run/stop is controlled by control terminals FX, RX and CM.

FX-CM: Run/stop control.

RX-CM: Forward and reverse control (toggle)

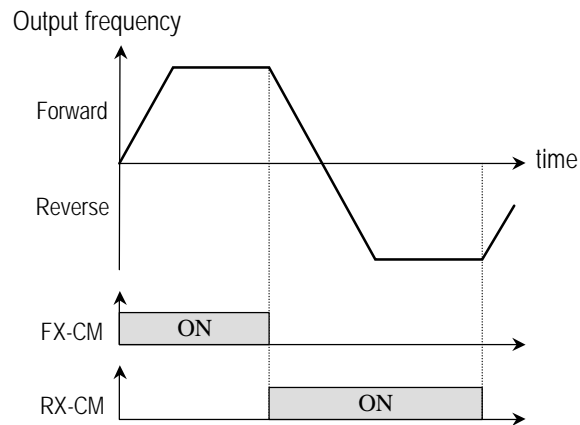

[Run/stop set: Terminal-1]

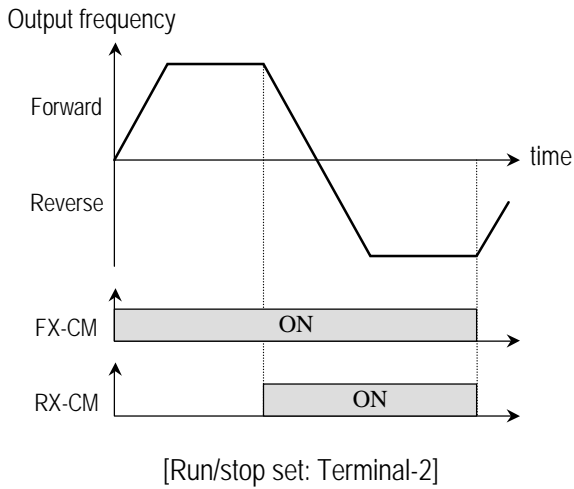

FUN 03: Run Prevention

Display:

FUN ϕ Run prohibit
03 None

Setting Range: None, FWD disable, REV disable

Description:

This function is to lock the direction of motor. To lock the direction, select FWD disable or REV disable.

FUN 04: Maximum Frequency
FUN 05: Base Frequency **FUN 06: Start Frequency**

Display: Maximum Frequency

FUN ϕ Freq. max
04 60.00 Hz

Setting Range: 40 to 400Hz

Display: Base Frequency

FUN ϕ Freq. base
05 60.00 Hz

Setting Range: 40 to FUN 04 [Freq. max]

Display: Start Frequency

FUN ϕ Freq. start
06 60.00 Hz

Setting Range: 0.5 to 5Hz

Description:

Maximum Frequency: This is the maximum output frequency of the inverter. Make sure that this maximum frequency does not exceed the rated speed of motor.

Base Frequency: This is the frequency that inverter outputs its rated voltage. In case of using 50Hz motor, set this frequency to 50Hz.

Starting Frequency: This is the frequency that inverter starts to output the voltage.

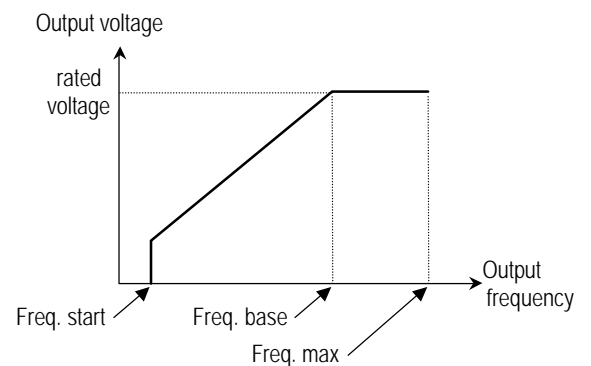

■ **Note:** If maximum frequency is decreased all frequency parameters related are limited to the maximum frequency.

FUN 07: Hold time

Display:

FUN ϕ Hold time
07 0.0sec

Setting Range: 0 to 10 sec

Description:

The inverter holds the starting frequency for the Hold time before accelerating.

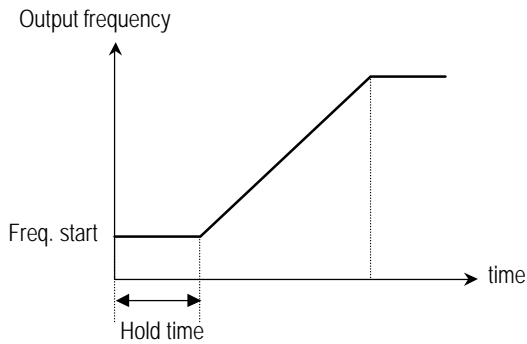

FUN 08: Volts/Hz Pattern

Display:

FUN ϕ V/F pattern
08 Linear

Setting Range: Linear, 1.5 (Squared), User, Auto

Description:

This is the pattern of voltage / frequency ratio. Select the proper V/F pattern according to the load. The motor torque is dependent on this V/F pattern.

Linear: [Constant Torque]

[Linear] pattern is used where constant torque is required. This pattern maintains a linear volts/hertz ratio from zero to base frequency – FUN 05 [Freq. base]. This pattern applies to conveyer, parking facility etc.

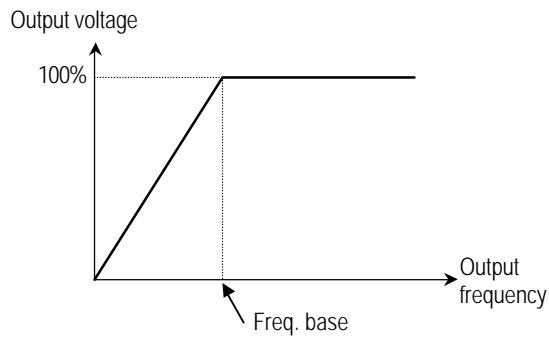

1.5 (Squared): [Variable Torque]

[1.5 (Squared)] pattern is used where variable torque is required. This pattern maintains squared volts/hertz ratio. This pattern applies to fan, pump etc.

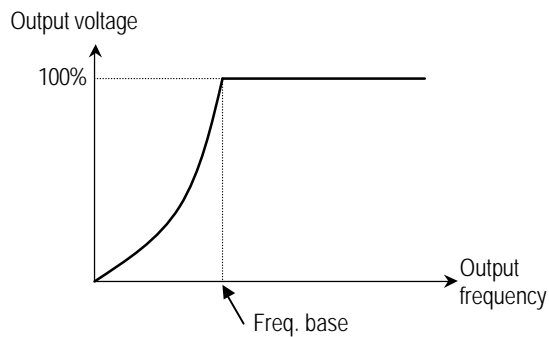

User: [Custom Pattern]

This pattern is used for special applications. Users can adjust the volts/hertz ratio according to applications. This is done by setting the voltage and hertz, respectively, at two points between starting frequency and base frequency. Refer to FUN 16 – 19 for volts/hertz setting.

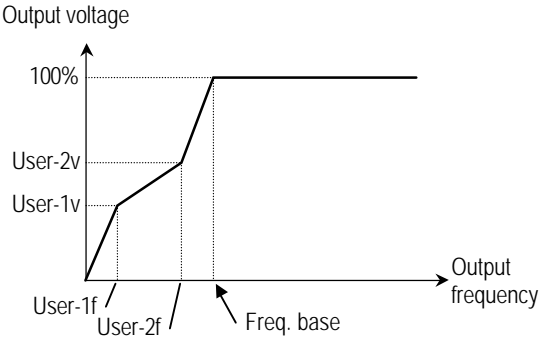

Auto: [Auto Boost]

[Auto] pattern is used where high starting torque is required. This pattern automatically changes the output voltage of the inverter within the boost value by sensing the load current. In some applications, this may cause OC trip or OC limit trip. Do not use this pattern if several motors are connected at one inverter.

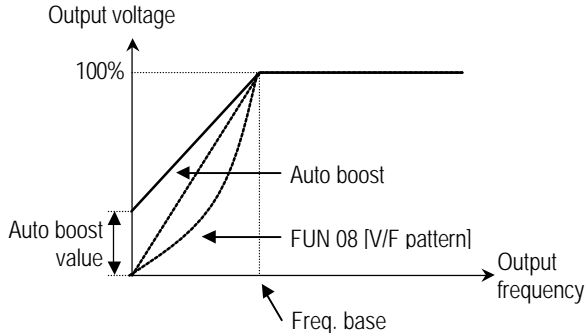

FUN 09, 10: Manual Torque Boost

Display:

FUN ϕ	Fwd boost
09	2 %

Setting Range: 0 to 20%

Display:

FUN ϕ	Fwd boost
10	2 %

Setting Range: 0 to 20%

Description:

The forward and reverse torque boost is set separately. This function is used to increase the starting torque by increasing the output voltage of inverter. If the boost value is set too high than required, it may cause the motor flux to saturate.

This manual boosts just work for the [Linear] and [1.5 (Squared)] V/F pattern, but not for the [User] and [Auto] V/F pattern. It is not recommended to use manual boost when [Auto] V/F pattern is selected in FUN 08 [V/F pattern].

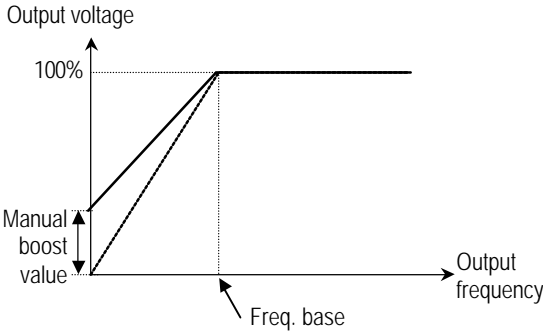

[Manual boost on Linear V/F pattern]

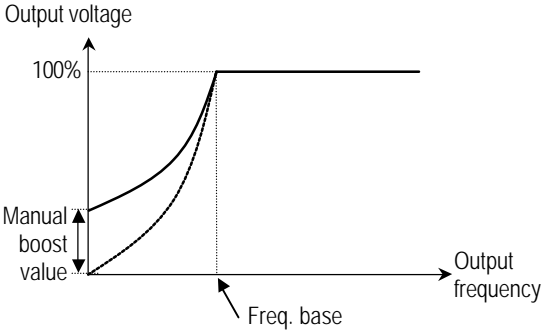

[Manual boost on 1.5 (Squared) V/F pattern]

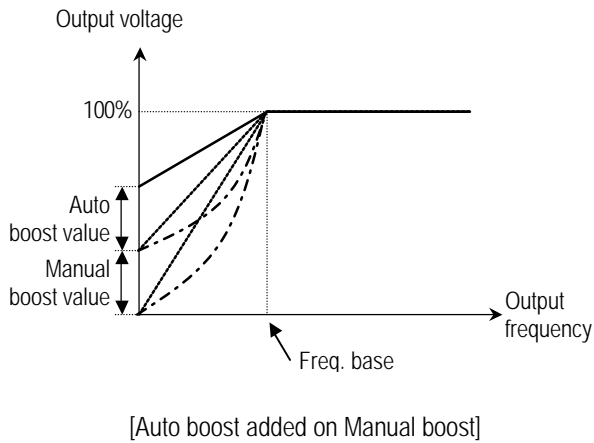

FUN 11: Acceleration pattern
FUN 12: Deceleration pattern

Display:

FUN ϕ Acc. pattern
 11 Linear

FUN ϕ Dec. pattern
 12 Linear

Setting Range: Linear, S-Curve, U-Curve

Description:

Users can select different combinations of acceleration and deceleration patterns according to the applications.

Linear: This is the general acceleration and deceleration pattern for constant torque applications.

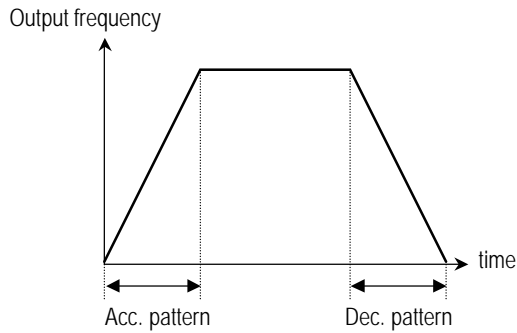

[Linear Acc./Dec. pattern]

S-Curve: This pattern allows the motor to accelerate and decelerate smoothly. At this time, the actual acceleration and deceleration time are longer about 10% than the acceleration and deceleration time set in FUN 01-02.

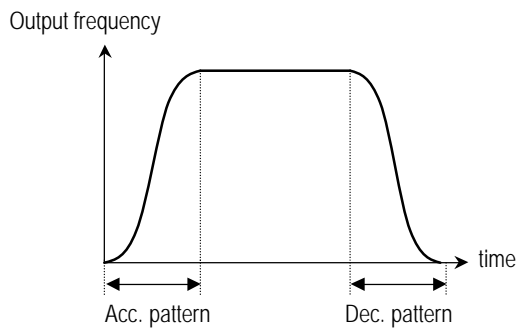

[S-Curve Acc./Dec. pattern]

U-Curve: This pattern provides more efficient control of acceleration and deceleration in the application like winding machines.

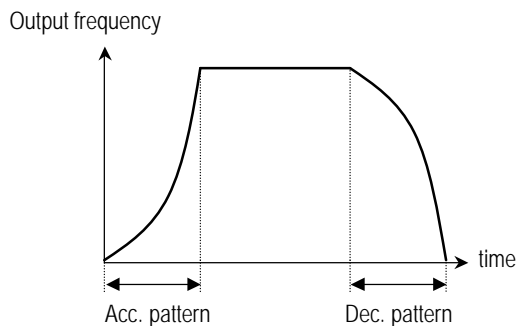

[U-Curve Acc./Dec. pattern]

FUN 13: Output Voltage adjustment

Display:

```
FUNϕ Volt control
13      100 %
```

Setting Range: 40 to 110%

Description:

This function is used to adjust the output voltage of inverter. This is useful when using a motor that has lower rated voltage than the main input voltage. When this is set at 100%, inverter outputs its rated voltage.

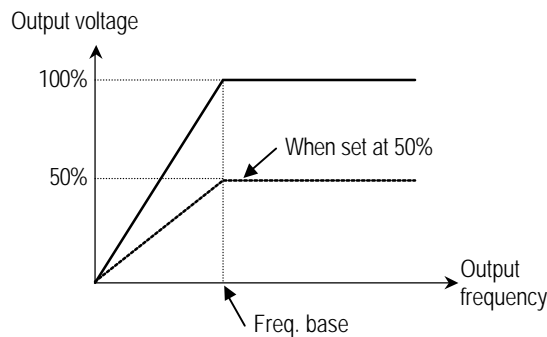

FUN 14: Energy Save operation

Display: Energy save level

```
FUNϕ Energy save
14      100 %
```

Setting Range: 30 to 100%

Description:

This function is used to reduce the output voltage in applications that do not require high torque and current at its steady speed. If the energy save level is set at 80%, inverter reduces its output

voltage after accelerating to the reference frequency (steady speed). This function may cause OC trip or OC limit trip due to the lack of output torque in fluctuated load. This function does not work with 100% set value.

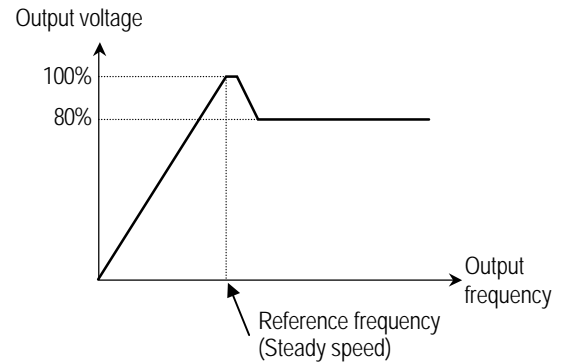

[When Energy save level set at 80%]

FUN 15: Stop Pattern selection

Display: Deceleration method

```
FUNϕ Stop mode
15      Decel
```

Setting Range: Decel, DCBR, Free Run

Description:

This function is used to select stop mode.

Decel: [Deceleration]

This is the general deceleration method. Inverter decelerates according to the pattern selected in FUN 12 [Dec. pattern].

DCBR: [DC Injection Braking]

This is used to stop the motor immediately by introducing DC voltage to the motor. The related parameters for DC braking are set in FUN 34 – 36.

Free Run: [Coast to Stop]

This is used to stop the motor by cutting off the inverter output. The motor is stopped by mechanical friction.

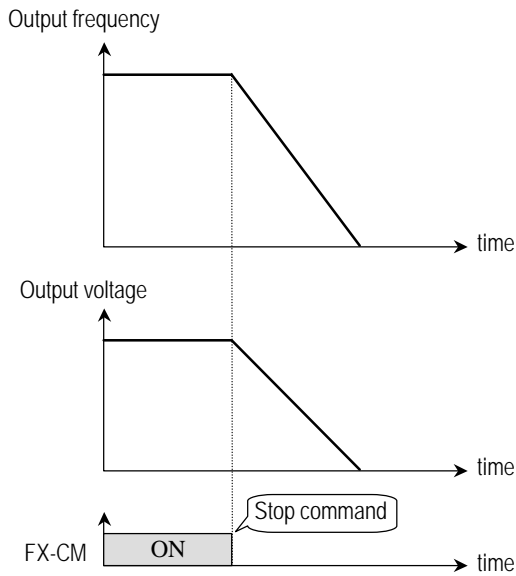

[Stop mode: Decel]

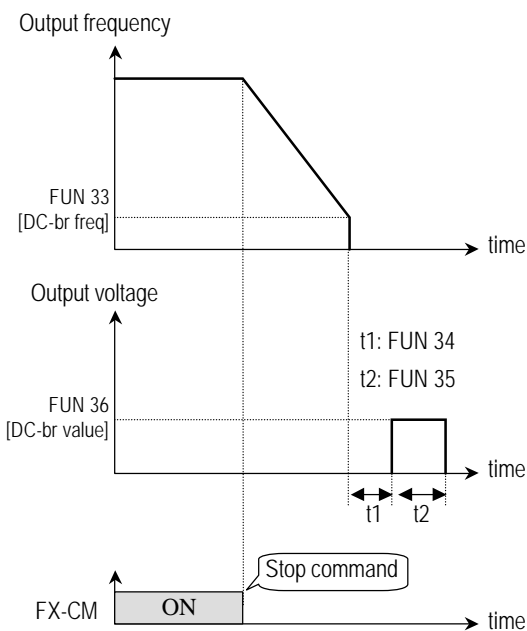

[Stop mode: DCBR]

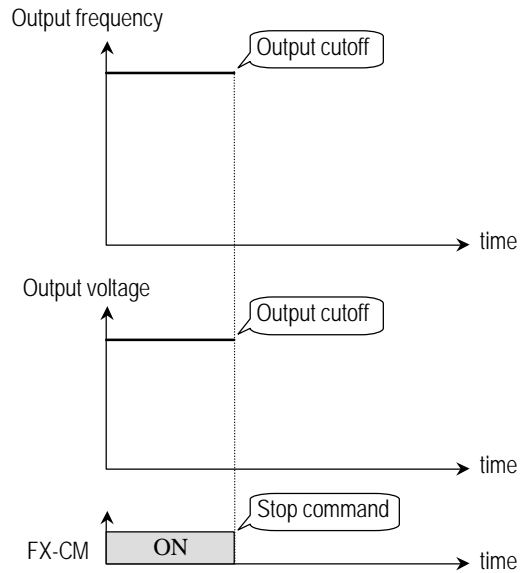

[Stop mode: Free Run]

FUN 16 - 19: User V/F pattern

Display: User V/F – Frequency 1

FUN ϕ User-1f
16 10.00 Hz

Setting Range: 0 to 30Hz

Display: User V/F – Frequency 1

FUN ϕ User-1v
17 15%

Setting Range: 0 to 50%

Display: User V/F – Frequency 2

FUN ϕ User-2f
18 30.00 Hz

Setting Range: FUN 16 to FUN 04

Display: User V/F – Frequency 2

FUN ϕ	User-2v
19	50%

Setting Range: FUN 17 to 100%

Description:

These functions are available only when [User] is selected in FUN 08 [V/F pattern]. Users can make the custom V/F pattern by setting four points including FUN 06-starting frequency and FUN 05-base frequency.

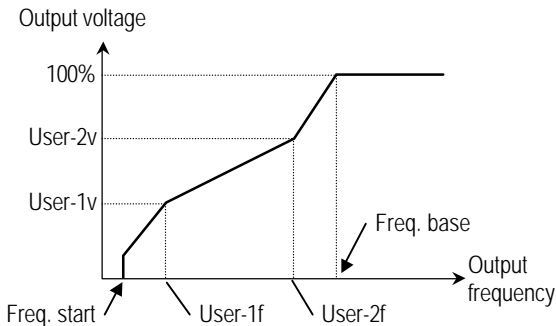

FUN 20: Analog Speed Ref. Selection

Display:

FUN ϕ	V-I mode
20	V1

Setting Range: V1, I, V1+I, V2

Description:

This is to select the kind of the signal of analog speed reference when the FUN 01 [Freq. set] is selected to [Terminal-1] of [Terminal-2].

V1: [Voltage 1]

A 0 to 10V DC signal is used for analog speed reference. When using a speed pot, connect it to VR, V1 and CM terminals.

I: [Current]

A 4 to 20mA signal is used for analog speed reference. Connect the current source to I and CM terminals.

V1+I: [Voltage 1+Current]

A 0 to 10V DC and a 4 to 20mA signals are used for analog speed reference at the same time. One signal overrides the other signal.

V2: [Voltage 2]

V2 has the same function as V1.

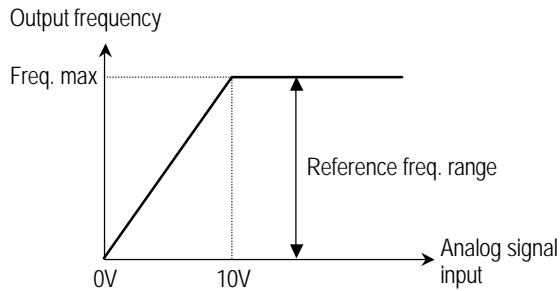

[V-I mode: V1 (Voltage 1)]

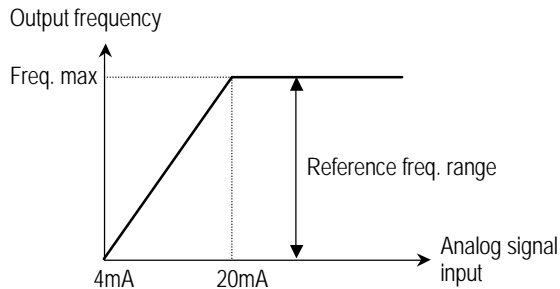

[V-I mode: I (Current)]

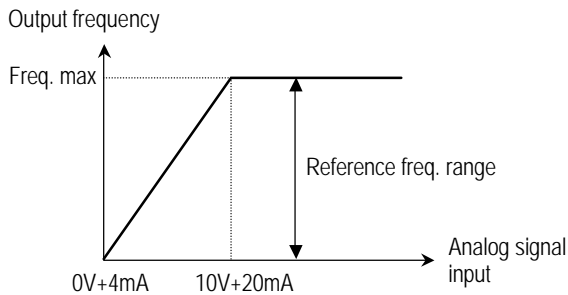

[V-I mode: V1+I (Voltage 1+Current)]

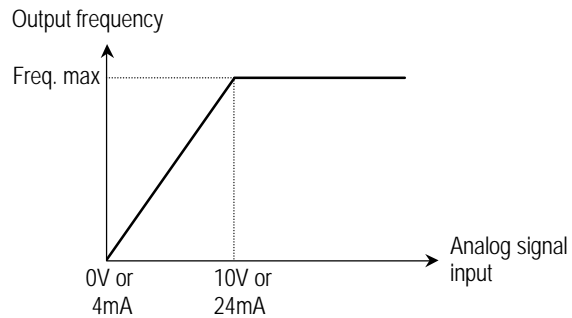

[Analog gain: 100%]

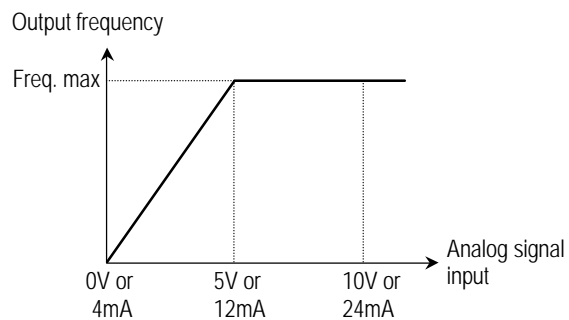

[Analog gain: 50%]

FUN 21 - 24: Analog Speed input related Parameters

Display: Analog speed input Filter Gain

FUN ϕ	Filter gain
21	50 %

Setting Range: 1 to 100%

Description:

This is used to regulate the response-time constant of the analog signal input for speed reference. For a faster and sensitive response to the signal input, set this value at low level. However, low filter gain may cause the inverter output to fluctuate.

Display: Analog speed input Scaling

FUN ϕ	Analog gain
22	100 %

Setting Range: 50 to 250%

Description:

This is used to scale the analog signal input. When this value is set at 50%, the inverter outputs maximum frequency at 5V DC or 12mA.

Display: Analog Speed Bias

FUN ϕ	Analog bias
23	0 %

Setting Range: 0 to 100%

Description:

Analog bias set the offset of the analog signal input at 0V or 4mA. Setting value is the percent of maximum frequency.

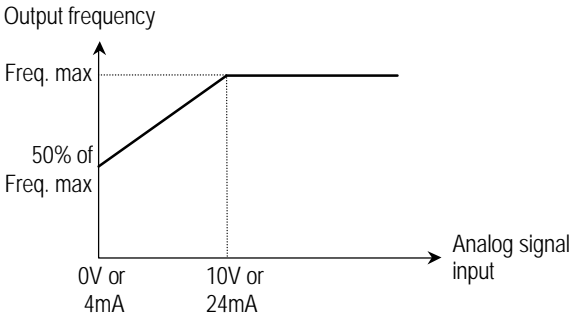

[Analog bias: 50%]

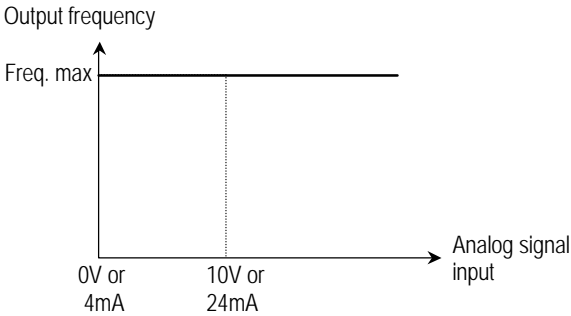

[Analog bias: 100%]

Display: Analog Speed direction

```

FUN#° Analog dir
24      Direct
    
```

Setting Range: Direct, Invert

Description:

The Output frequency-Analog signal input curve can be inverted by selecting [Inverse].

Direct: The output frequency is directly proportional to the analog signal input.

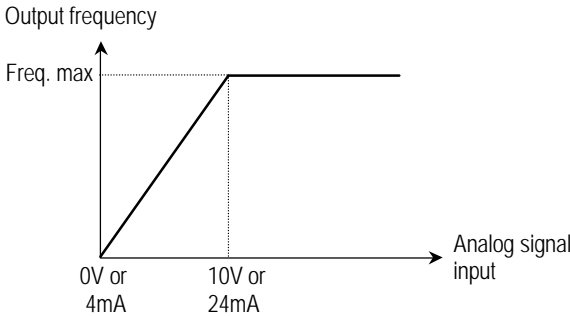

[Analog dir: Direct]

Invert: The output frequency is inversely proportional to the analog signal input.

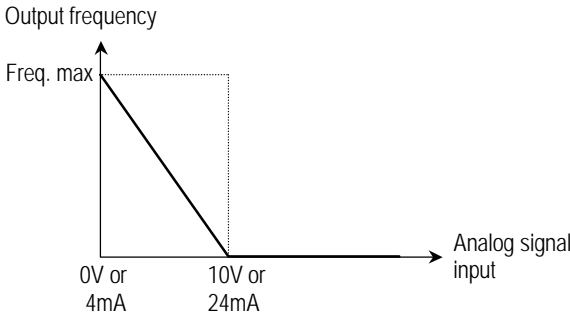

[Analog dir: Invert]

FUN 25 - 27: Frequency High / Low Limits

Display: Frequency limits selection

```

FUN#° Freq. limit
25    --- No ---
    
```

Setting Range: No, Yes

Description:

Select whether frequency limit function is used or not.

Display: Frequency high limit

```
FUN# F-limit high
26      60.00 Hz
```

Setting Range: 0 to FUN 04 [Freq. max]

Display: Frequency low limit

```
FUN# F-limit low
27      0.00 Hz
```

Setting Range: 0 to FUN 26 [F-limit high]

Description:

These functions limit the output frequency between the frequency high and frequency low limits.

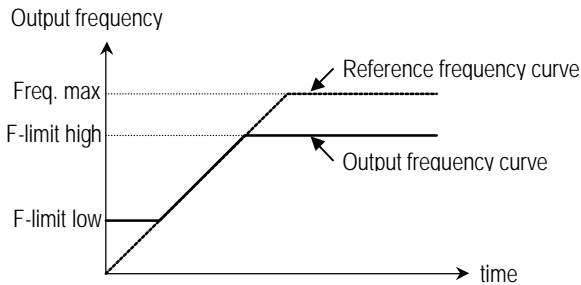

[Freq. limit: Yes]

- **Note:** The reference frequency may be set at above the frequency high limit or below the frequency low limit. However, the output frequency is limited by the limits.
- **Note:** When accelerating or decelerating, the output frequency follows the reference frequency curve.

FUN 28 - 32: Frequency Jump

Display: Frequency jump selection

```
FUN# Freq. jump
28 --- No ---
```

Setting Range: No, Yes

Display: Frequency jump 1

```
FUN# Freq-jump 1f
29      10.00 Hz
```

Setting Range: 0 to FUN 04 [Freq. max]

Display: Frequency jump 2

```
FUN# Freq-jump 2f
30      20.00 Hz
```

Setting Range: 0 to FUN 04 [Freq. max]

Display: Frequency jump 3

```
FUN# Freq-jump 3f
31      30.00 Hz
```

Setting Range: 0 to FUN 04 [Freq. max]

Display: Bandwidth of jump frequency

```
FUN# Freq. band
32      5.00 Hz
```

Setting Range: 0 to 30Hz

Description:

To prevent undesirable resonance and vibration on the structure of the machine, this function

locks out the resonance frequency from operation. Each jump frequency also has a bandwidth. This is a span of the particular jump frequency selected. Three different jump frequencies can be set. However, there is only one bandwidth frequency available. This jumping of frequencies does not occur during accelerating or decelerating. It only occurs during continuous operation. To use just one jump frequency, both Frequency jump 1 and Frequency jump 2 should be set 0 Hz. To use two jump frequencies, Frequency jump 3 should be set 0 Hz.

- **Note:** When the reference frequency is set inside the jump frequency, the output frequency goes to the frequency marked by “●” symbol.

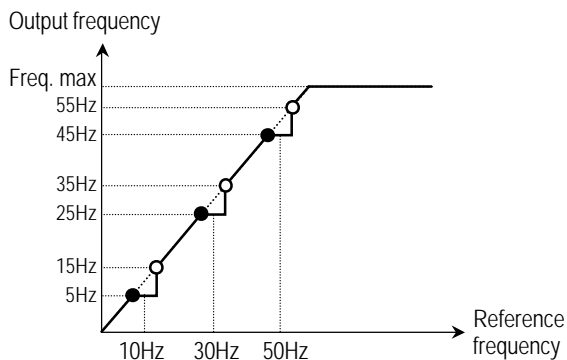

Example:

Jump frequency #1 is set to 10Hz.
 Jump frequency #2 to 30Hz.
 Jump frequency #3 to 50Hz and the bandwidth of the jump frequency to 5Hz.

Avoidance range #1 is 5.01Hz – 15Hz.
 Avoidance range #1 is 25.01Hz – 35Hz.
 Avoidance range #1 is 45.01Hz – 55Hz.

FUN 33 - 36: DC Injection Braking

Display: DC injection braking frequency

FUN ϕ ° DC-br freq
33 0.5 Hz

Setting Range: 0 to 60Hz

Display: DC injection braking on-delay time

FUN ϕ ° DC-br block
34 2.0 sec

Setting Range: 0.5 to 5 sec

Display: DC injection braking time

FUN ϕ ° DC-br time
35 0.5 sec

Setting Range: 0.1 to 25 sec

Display: DC injection braking voltage

FUN ϕ ° DC-br value
36 1 %

Setting Range: 1 to 20 %

Description:

The DC injection braking function is enabled in FUN 15 [Stop mode]. This is used to bring the motor to a quick stop. This function can also be used to hold the motor with torque at zero speed for short periods of time.

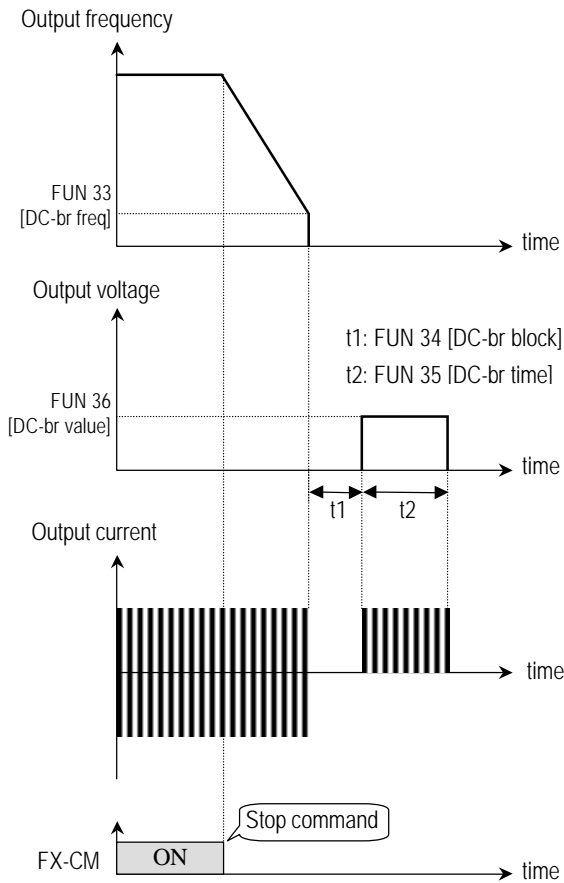

[DC Injection Braking with 'Stop mode: DCBR']

- Note:** The on-delay time must be set according to the DC injection braking frequency and the magnitude of the load. If the on-delay time is set 0 sec, the drive may trip on overcurrent. This is because the DC voltage flows before the motor's magnetic field and voltage have decayed.

FUN 37 - 40: Slip Compensation

Display: Slip Compensation selection

FUN ϕ Slip compen.
37 --- No ---

Setting Range: No, Yes

Display: Rated slip of motor

FUN ϕ Rated slip
38 0.00 Hz

Setting Range: 0 to 5Hz

Display: Rated current of motor (RMS)

FUN ϕ M-rated cur.
39 122.0 A

Setting Range: 0.1 to 999A

Display: No-load current of motor (RMS)

FUN ϕ No-load cur.
40 0.1 A

Setting Range: 0.1 to 300A

Description:

This function is used to maintain the motor speed constantly. To keep the motor speed constant, the output frequency varies within the limit of slip frequency-FUN 38 [Rated slip] according to the load current. For example, when the motor speed decreases below the reference speed (frequency) due to a heavy load, the inverter increases the output frequency higher than the reference frequency to increase the motor speed. The inverter increases or decreases the output by delta frequency shown below.

$$\text{Delta Freq.} = \frac{\text{Output current} - \text{No-load current}}{\text{Rated current} - \text{No-load current}} \times \text{Rated slip}$$

Output frequency = Reference freq. + Delta freq.

FUN 41: Inverter Capacity**Display:** Inverter capacity

FUN ϕ Inv Capacity
41 SV030iH-2

Setting Range: by model and size ID # of drive**Description:**

Set inverter capacity. This must be set correctly for proper current calculation and protective functions. After initializing all parameters, this should be set first.

****See Page 31 for cross-reference to new CMC Model Numbers.**

FUN 42 - 43: Auto Restart**Display:** Auto restart number

FUN ϕ Retry number
42 0

Setting Range: 0 to 10**Display:** Auto restart waiting time

FUN ϕ Retry time
43 1.0sec

Setting Range: 0 to 10 sec**Description:**

This function is used to allow the inverter to reset itself for a selected number of times after a fault occurs. When an overvoltage, overcurrent, ground fault or overcurrent limit fault occurs, the drive can restart itself automatically. This function uses the speed search function. See FUN 56, FUN 57, FUN 58.

When an undervoltage fault or inverter disable

(BX) occurs, the drive does not restart automatically.

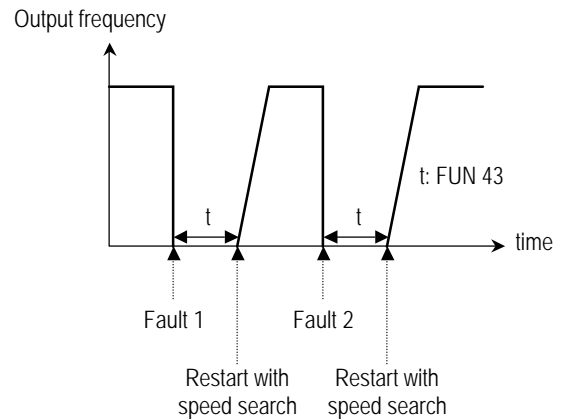

- Note: Inverter decreases the retry number by ones as a fault occurs. When restarted without a fault during 30 seconds, the inverter increases the retry number by ones.

FUN 44: Fault Output Relay (A, B, C)**Display:** Fault Output Relay Mode selection

FUN ϕ Relay mode
44 Retry 0

Setting Range: Retry 0, All Trips, LV+Retry 0, LV+All Trips

Description:

This function is used to allow the fault output relay to operate after a fault. The output relay terminals are A, B, C on control terminal strip.

Retry 0: The output relay operates when the retry number decreases to 0 by faults. When the retry number is set to 0 by default, the relay operates at any faults **except** at undervoltage and BX (inverter disable) fault.

All Trips: The output relay operates on all faults **except** undervoltage and BX (inverter disable) fault. The output relay operates regardless of the retry number.

LV+Retry 0: In case of an undervoltage fault or a 0 restart count, the output relay operates. For a BX (inverter disable) input, the relay does NOT operate.

LV+All Trips: When a fault including undervoltage occurs, the output relay operates. In BX (inverter disable), the relay does NOT operate. The output relay operates regardless of the retry number.

FUN 45 - 46: Stall Prevention

Display: Stall Prevention mode selection

FUN ϕ Stall mode
45 None

Setting Range: None, Acc, Steady, Acc+Steady, Dec, Acc+Dec, Dec+Steady, Acc+Dec+Std

Display: Stall Prevention level

FUN ϕ Stall level
46 150 %

Setting Range: 30 to 150%

Description:

This function is used to prevent the motor from stalling by reducing the inverter output frequency until the motor current decreases below the stall prevention level.

Acc: During acceleration, when the output current of the inverter has reached the stall prevention level, the drive stops accelerating. When the current reduces below the stall prevention level, the drive will begin to accelerate again.

Steady: During steady state, when the output current of the inverter reaches the stall prevention level, the drive reduces its output frequency. When the current is reduced below the stall prevention level, the drive returns to its command frequency.

Dec: During deceleration, when the DC link voltage reaches the maximum design voltage, the drive stops deceleration. The maximum designed voltages are 390V DC for 230V rated drives and 680V DC for 460V rated drives.

■ Note: If overvoltage fault occurs during deceleration, use a dynamic braking resistor or a longer deceleration time.

Acc+Steady: Stall prevention is active during acceleration and steady state operation.

Acc+Dec: Stall prevention is active during acceleration and deceleration.

Dec+Steady: Stall prevention is active during deceleration and steady state operation.

Acc+Dec+Std: Stall prevention is active during acceleration, deceleration and steady state operation.

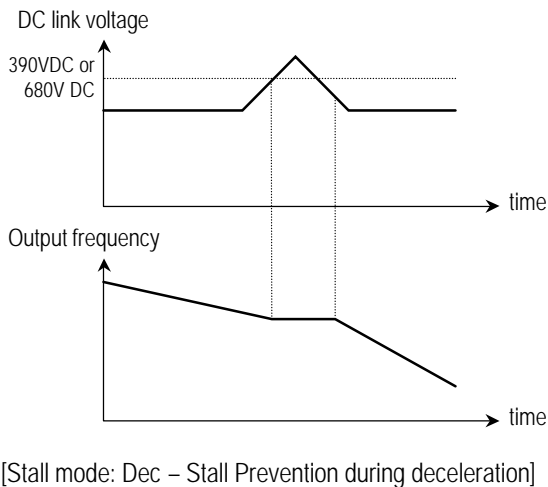
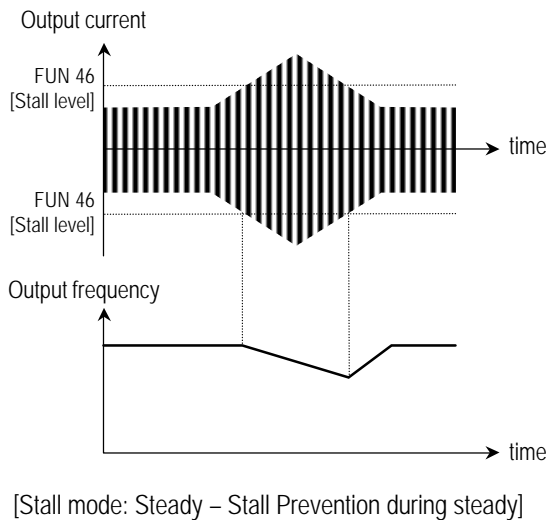
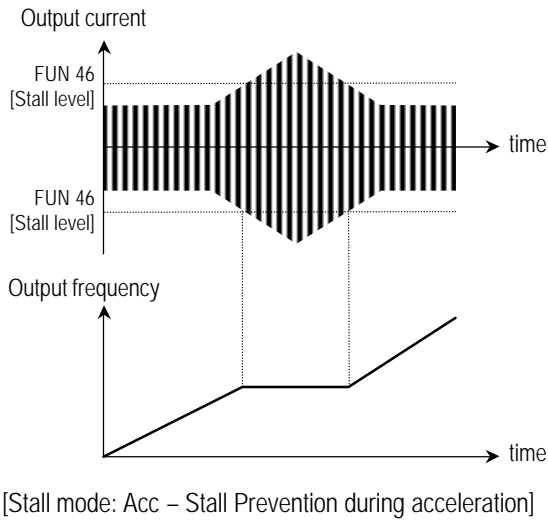

FUN 47 - 48: Overload Warning

Display: Overload warning level

FUN ϕ ° OL level	
47	150 %

Setting Range: 30 to 150%

Display: Overload warning time

FUN ϕ ° OL time	
48	10.0sec

Setting Range: 1 to 30 sec

Description:

This function is used to provide motor overload detection. When the output current of the inverter has reached an overload warning level, a multi-output signal will turn on.

Application:

For example, define multi-output OC1 in I/O [OC1 Output] to OL. The multi-output is open collector (24V DC, 50mA).

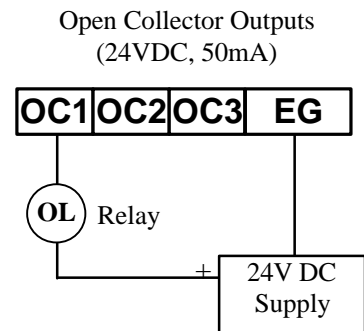

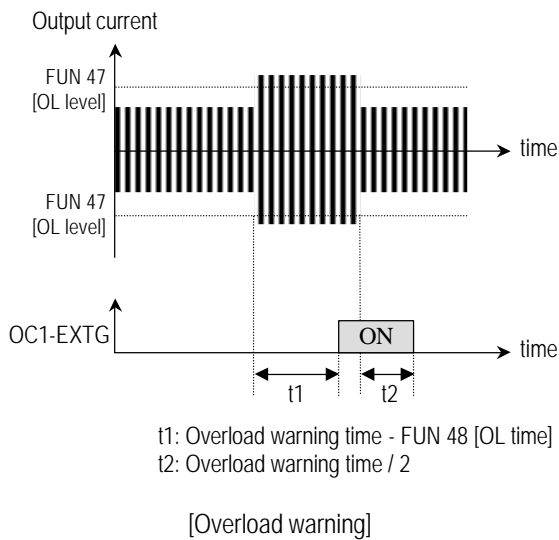

FUN 49 - 50: Overcurrent limit trip

Display: Overcurrent limit level

```
FUNϕ°OC lim level
49      160 %
```

Setting Range: 30 to 200%

Display: Overcurrent limit time

```
FUNϕ°OC lim. time
50      60.0sec
```

Setting Range: 0 to 60 sec

Description:

When output current of the inverter has reached the over current limit level and times out, the drive cuts off the output and stops. This function protects against abnormal load conditions.

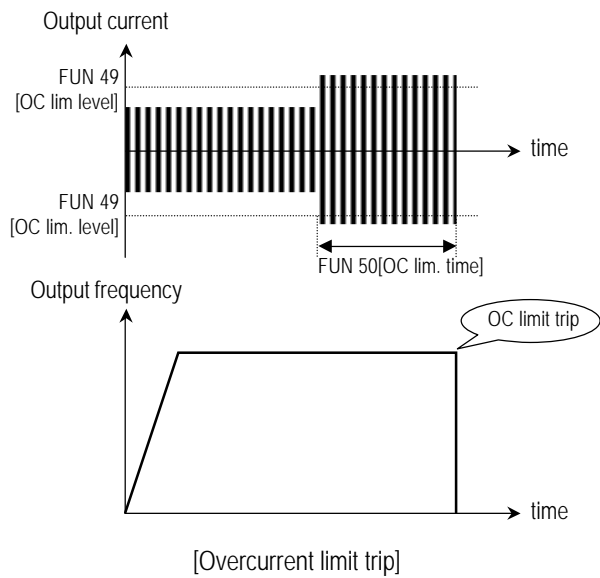

FUN 51-53: Electronic thermal (ETH)

Display: Electronic thermal (ETH) selection

```
FUNϕ° ETH select
51 --- No ---
```

Setting Range: No, Yes

Display: Electronic thermal (ETH) level

```
FUNϕ° ETH level
52      150 %
```

Setting Range: 30 to 150%

Display: Motor type selection

```
FUNϕ° Motor type
53      General
```

Setting Range: General, Special

Description:

This function is designed to compensate for the lack of motor cooling effect during low frequency operation. If this function is active, one of two electronic thermal characteristics must be selected. The selections are 'General' for a standard AC induction motor and 'Special' for a special motor containing a separate blower.

- **Note:** ETH trip time is 60 seconds based on the ETH level.

Application:

To select the ETH level, use the following formula.

ETH level formula:

$$\text{ETH Level (\%)} = K \times \frac{\text{Motor rated current}}{\text{Inverter rated current}} \times 100$$

If 50 Hz input power, K = 1.0

If 60 Hz input power, K = 1.1

For a 'General' motor,
ETH time = 60 × ((motor rated current × output frequency × ETH level) / (output current × 60Hz × 100))

For a 'Special' motor,
ETH time = 60 × ((motor rated current × ETH level) / (output current × 100))

- **Note:** If the capacity of the motor is lower than that of the inverter, the ETH level should be set using the above formula.

FUN 54: Number of motor poles

Display:

```
FUN# Pole number
54                4
```

Setting Range: 2 to 12

Description:

Set the number of motor poles (used to display speed)

FUN 55 - 58: IPF (Instant Power Failure) restart and Speed Search

Display: IPF Restart selection

```
FUN# IPF select
55 --- No ---
```

Setting Range: No, Yes

Display: Acceleration time for speed search

```
FUN# ss acc. time
56                5.0sec
```

Setting Range: 0.1 to 600sec

Display: Deceleration time for speed search

```
FUN# ss dec. time
57                10.0sec
```

Setting Range: 0.1 to 600sec

Display: Speed-Search gain

```
FUN# ss gain
58                100 %
```

Setting Range: 0 to 200%

Description:

This function is used to permit automatic restarting after an instantaneous power failure of over 15 milliseconds without waiting for the motor to stop. The inverter can be programmed to restart after the AC power has been restored.

The speed search function also used when the inverter bypass to commercial line.

- The speed search gain and acc/dec time should be set after considering the inertia moment (GD^2) and magnitude of torque of the load.

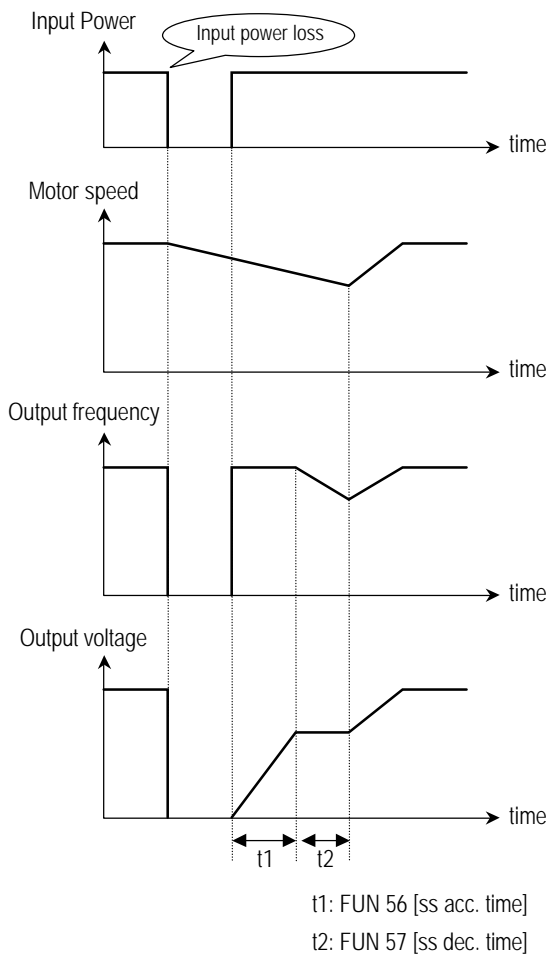

[IPF restart and Speed Search]

FUN 59: Restart after reset

Display: Restart selection after fault reset

FUN ϕ : RST-restart
59 --- No ---

Setting Range: No, Yes

Description:

If FUN 59 is set to 'Yes', the drive will restart after a fault has been reset by the RST (reset) terminal. If set to 'No', the FX or RX terminal should be connected to CM terminal again after resetting the fault.

- **Note:** In case of using 'Reset restart' to 'Yes', be sure to check safety before resetting a fault.

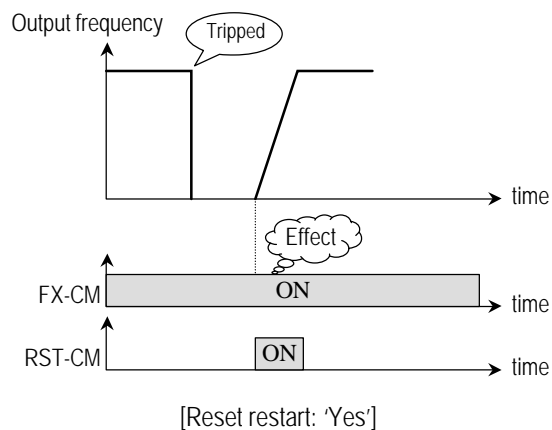
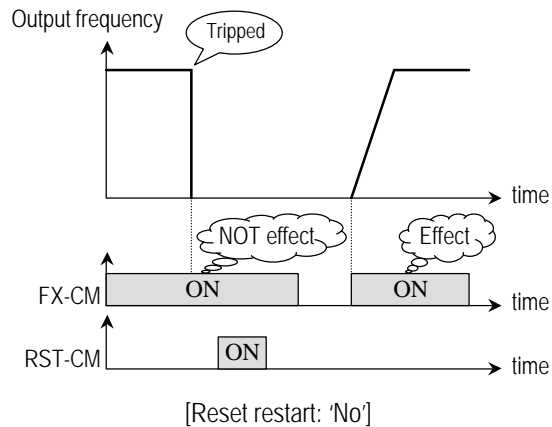

FUN 60: Restart after power on

Display: Restart selection after power on

```
FUN#° Power on st
60 --- No ---
```

Setting Range: No, Yes

Description:

If this function is set to 'Yes', the drive will restart after power is restored. If set to 'No', the FX or RX terminal should be connected to CM terminal again after power is restored.

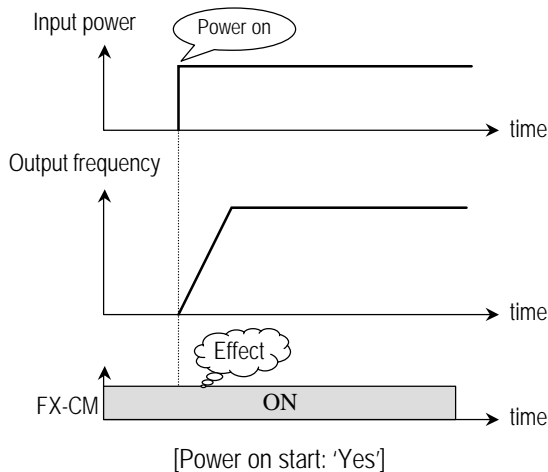
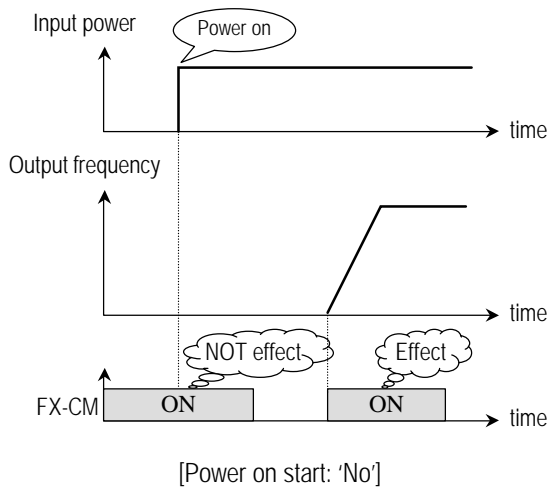

■ **Note:** In case of using 'Power on start' to 'Yes', be sure to check safety before resetting a fault.

FUN 61: Carrier frequency

Display:

```
FUN#° Carrier Freq
61      6 kHz
```

Setting Range: see page 28

Description:

This function sets the switching frequency for the PWM generator. It can be used to prevent harmonic resonance in machines and motors. If the carrier frequency is low, the electronic noise, leakage current and inverter heating will be reduced. Therefore, a lower carrier frequency is recommended in high ambient temperature environments. If the carrier frequency is high, the audible noise from the motor will be reduced.

FUN 62 - 66: PI control

Display: PI control selection

```
FUN#° PI-control
62 --- No ---
```

Setting Range: No, Yes

Display: P-gain

```
FUN#° P-gain
63      10
```

Setting Range: 1 to 30,000

Display: I-gain

FUN ϕ °	I-gain
64	50

Setting Range: 1 to 30,000

Display: Feedback offset

FUN ϕ °PI-FB	Offset
65	0

Setting Range: 0 to 50

Display: Feedback scale

FUN ϕ °PI-FB	scale
66	100

Setting Range: 1 to 250

Description:

The PI function automatically maintains a control set-point such as speed, temperature, pressure or flow. This function compares a feedback signal (provided externally) along with a set-point command (provided externally) to maintain a desired process speed. The feedback signal will provide information for the drive to compare its output speed and make the adjustments needed to target the set-point.

- Use the FUN 64 [Integral Gain] to control the drives response time to the feedback signal.
- Use the FUN 64 [Proportional Gain] to control the target window in which the drives maintains control.
- Use FUN 65 - 66 for control feedback scaling.
- The set-point command frequency is an analog voltage command (0 to 10V DC).
- The feedback signal is a 4 to 20mA.

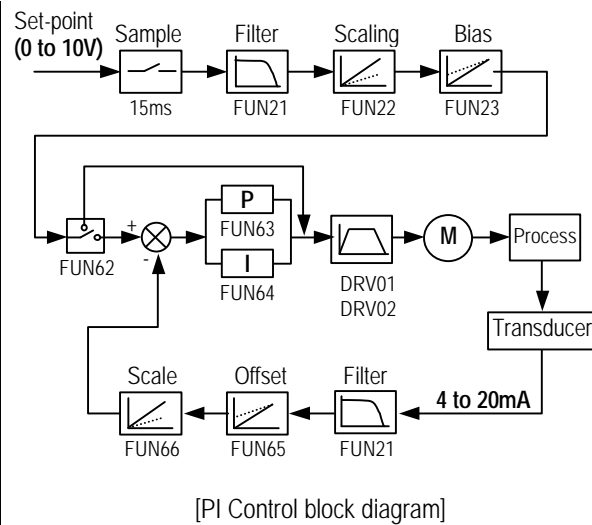

FUN 67: Read parameter

Display:

FUN ϕ °	Para. read
67	--- No ---

Setting Range: No, Yes

Description:

This function is used to copy all parameters from the drive to the keypad.

FUN 68: Write parameter

Display:

FUN ϕ °	Para. write
68	--- No ---

Setting Range: No, Yes

Description:

This function is used to copy all parameters from the keypad to the drive.

FUN 69: Initialize parameter**Display:**

```
FUN $\phi^{\circ}$  Para. init
69    --- No ---
```

Setting Range: No, Yes**Description:**

This function is used to return all of the parameters to their original factory default setting.

- Initializing the parameters to factory default settings also initialize the drive capacity parameter (FUN 41). Once the parameters are initialized to their factory defaults, FUN 41 must be set to its proper model name.

FUN 70: Lock parameter**Display:**

```
FUN $\phi^{\circ}$  Para. lock
70                                0
```

Setting Range: 0 to 255**Description:**

This function will prevent changes from being made to the parameters set in the drive. When the parameters are locked, the display arrow changes from solid to outlined.

```
FUN $\phi^1$  Para. lock
70                                0
```

The lock and unlock code is '12'.

5.3 I/O Group

I/O 00: Jump to desired code

Display:

```
I/O#° Jump Code
00                1
```

Setting Range: 1 to 60

Description:

Any program code may be jumped to directly by entering the desired program code number.

Application:

Jump to any I/O parameter code by pressing the [PROG] key, scrolling to desired code with [Arrow] keys and then pressing the [ENTER] key.

I/O 01 - 06: Multi-function Input definition

Display: P1, Multi-function input 1 definition

```
I/O#° P1 Input
01      SPD_L
```

Display: P2, Multi-function input 2 definition

```
I/O#° P2 Input
02      SPD_M
```

Display: P3, Multi-function input 3 definition

```
I/O#° P3 Input
03      SPD_H
```

Display: P4, Multi-function input 4 definition

```
I/O#° P4 Input
04      ACCT_L
```

Display: P5, Multi-function input 5 definition

```
I/O#° P5 Input
05      ACCT_M
```

Display: P6, Multi-function input 6 definition

```
I/O#° P6 Input
06      ACCT_H
```

Setting Range: **SPD_L**
SPD_M
SPD_H
JOG
ACCT_L
ACCT_M
ACCT_H
UP
DOWN
HOLD
OPT_MAN
COMM_CONN
EXT_DCBR
EXT_TRIP

Description:

Multi-function input terminals can be defined for several different applications.

SPD_L, SPD_M, SPD_H: [Multi-step Speed]

Defined as pre-set speed selection, each step and speed should be determined in advance.

Multi-step Speed selection table

	Speed 0	Speed 1	Speed 2	Speed 3	Speed 4	Speed 5	Speed 6	Speed 7
SPD_L	0	1	0	1	0	1	0	1
SPD_M	0	0	1	1	0	0	1	1
SPD_H	0	0	0	0	1	1	1	1

0: inactive (off), 1: active (on)

Example:

P1 is configured as SPD_L.

P2 is configured as SPD_M.

P3 is configured as SPD_H.

P4 is configured as JOG.

Speed 0 is set in DRV 00 through keypad or analog speed pot.

Speed 1 – 7 are set in I/O 13 – 19.

Jog frequency is set in I/O 12 and the drive direction can be determined by the FX, RX terminals.

Pre-set step speeds using P1, P2, P3, P4, FX, RX are shown as follows.

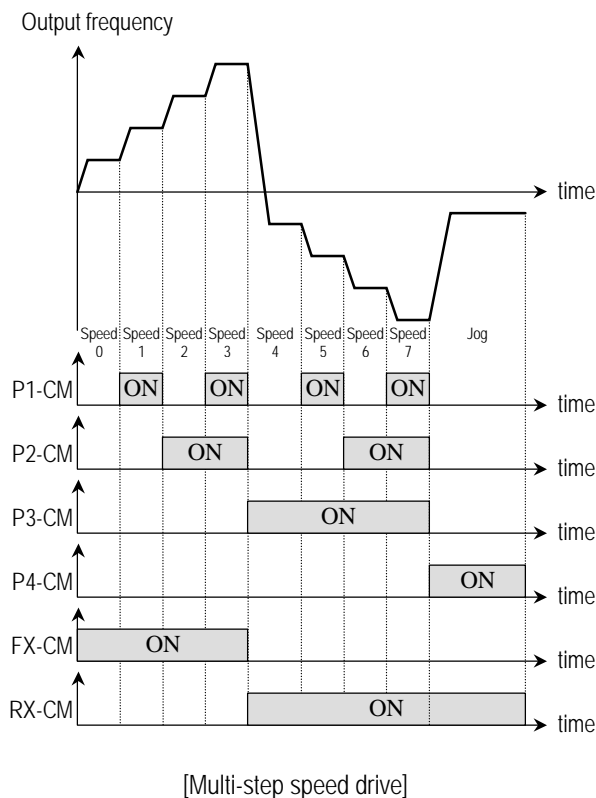

JOG: [Jogging Frequency]

Jog frequency is set in I/O 12.

ACCT_L, ACCT_M, ACCT_H: [Multi-Acceleration/Deceleration time]

Up to 7 different accel/decel times can be programmed. The accel/decel times are selected by binary coding of the multi-function input terminals and shown in the table below.

Multi-Accel / Decel time selection table

	Time 0	Time 1	Time 2	Time 3	Time 4	Time 5	Time 6	Time 7
ACCT_L	0	1	0	1	0	1	0	1
ACCT_M	0	0	1	1	0	0	1	1
ACCT_H	0	0	0	0	1	1	1	1

0: inactive (off), 1: active (on)

The Time 0 Accel/Decel time is configured by DRV 01-02 and selected when no Accel/Decel input terminals are active. The Time 1-7 Accel/Decel times are set in I/O 20-33.

Example:

If P4 is configured as ACC_L, P5 as ACCT_M and P6 as ACCT_H, then the transition time can be selected by P4, P5 and P6 terminals.

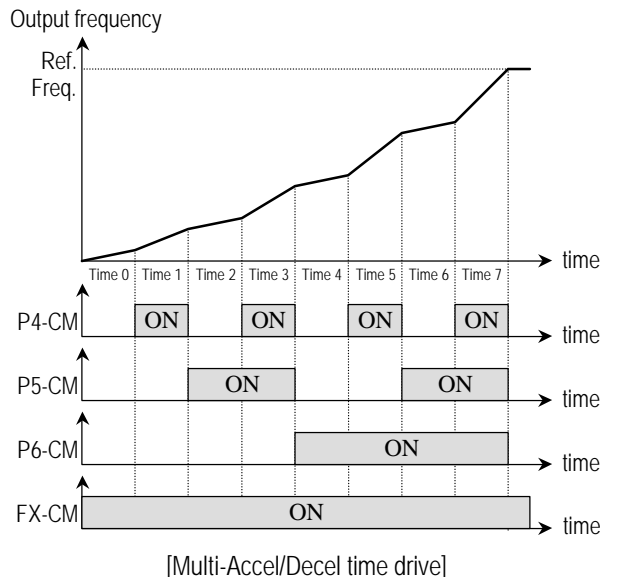

UP, DOWN:

By using the Up and Down function, the drive can accelerate to a steady speed and decelerate down to a desired speed by using only two input terminals.

Example:

If P1 is configured as 'UP' and P2 as 'DOWN', then Up/Down operation can be achieved using P1 and P2 terminals.

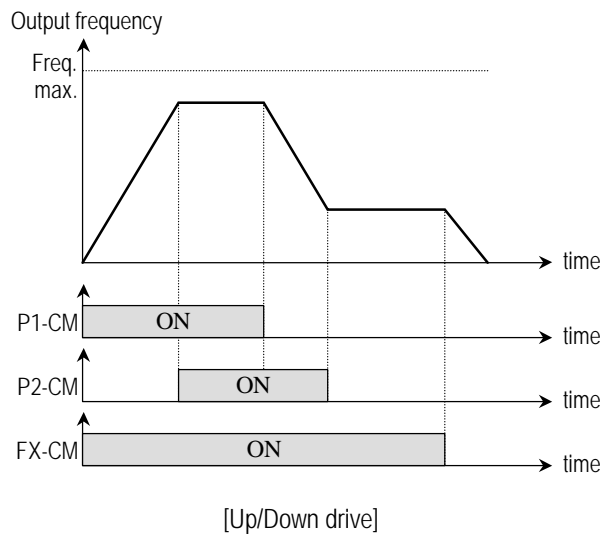

HOLD:

This function is for 3-wire star/stop operation. This function is mainly used as a momentary push button to hold the current frequency output during acceleration or deceleration.

Example:

If P2 is configured as 'HOLD'.

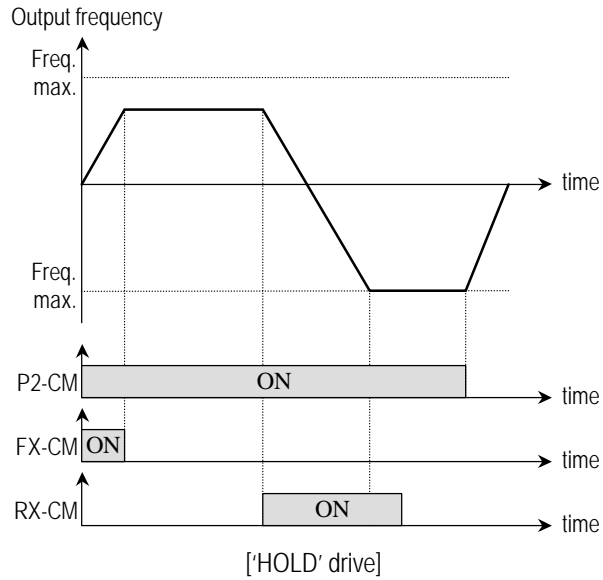
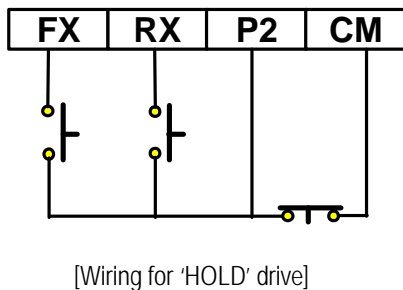

OPT_MAN: Reserved for future use

COMM_CONN:

Used for the bypass (commercial line exchange) command. See Chapter 8 – Application Notes, section 8.3 – Exchange Inverter to Commercial Line Operation.

EXT_DCBR:

Used as the DC-braking control input terminal. When the drive is in stop mode the DC braking will be used if this terminal is closed. The voltage level of DC-braking is the value of FUN 36 [DC-br value].

Example:

If P4 is configured as EXT_DCBR, then DC injection braking is achieved on stop by using P4 input terminal.

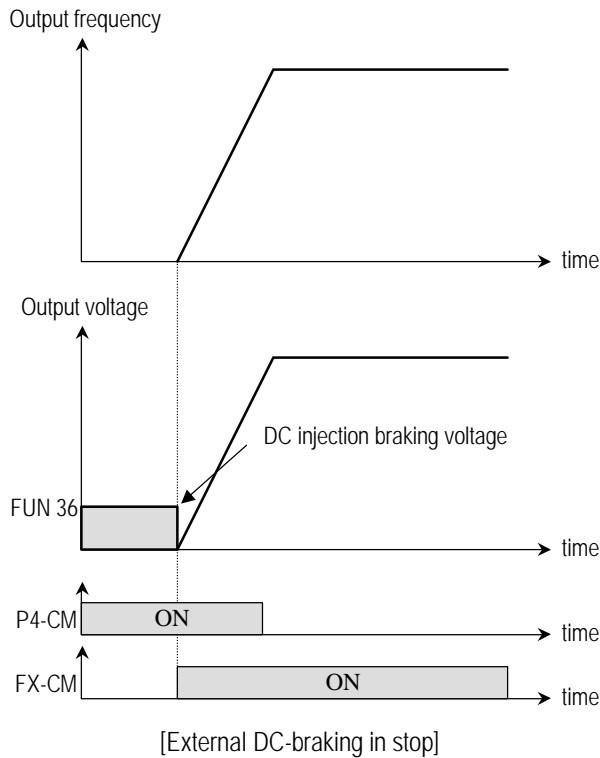

EXT_TRIP:

Used for external fault input.

- **Closing state:** normal operation
- **Open state:** fault occurred

I/O 07 - 11: Multi-function Output definition

Display: OC1, Multi-function output definition

I/O# OC1 output
07 STEP_L

Display: OC2, Multi-function output definition

I/O# OC2 output
08 STEP_M

Display: OC3, Multi-function output definition

I/O# OC3 output
09 STEP_H

Display: AUX1, Relay (1A, 1B) definition

I/O# AUX1 output
10 COMM

Display: AUX2, Relay (2A, 2B) definition

I/O# AUX2 output
11 COMM

- Setting Range:**
- FST_LO
 - FST_HI
 - FDT_HI
 - FDT_PULSE
 - FDT_BAND
 - OL
 - STALL
 - LV
 - RUN
 - COMM
 - STEP_L
 - STEP_M
 - STEP_H

Description:

The user can define multi-function output terminals. OC1, OC2, OC3 are open collector outputs and AUX1 (1A, 1B terminal), AUX2 (2A, 2B terminal) are relay outputs.

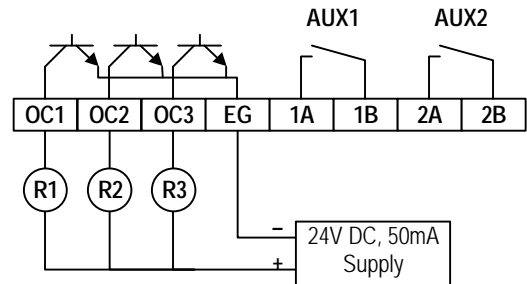

FST_LO:

The output frequency is compared with FST frequency in I/O 38 [FST-freq]. When the output frequency is below the FST frequency, the output is turned on.

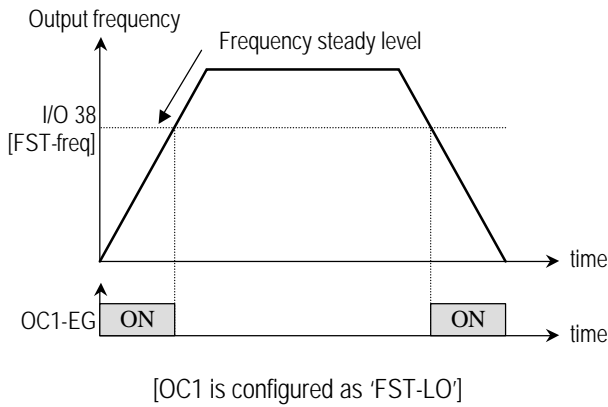

FST_HI:

The output frequency is compared with FST frequency in I/O 38 [FST-freq]. When the output frequency is above the FST frequency, the output is turned on.

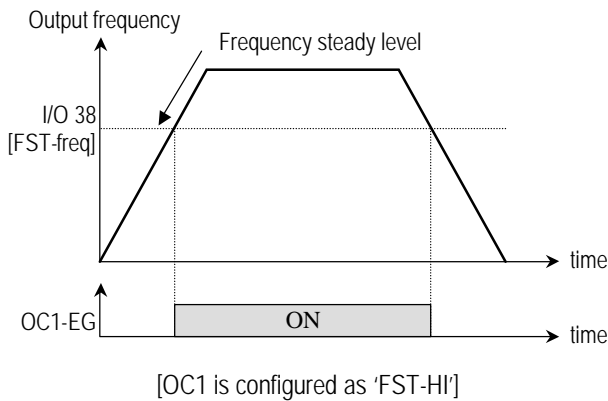

FDT_HI:

The output frequency is compared with FDT frequency in I/O 39 [FDT-freq] and FDT band in I/O 40 [FDT-band]. When the output frequency is above the FDT frequency, the output is turned

on. The output is turned off when the output frequency goes below the FDT frequency minus the FDT band.

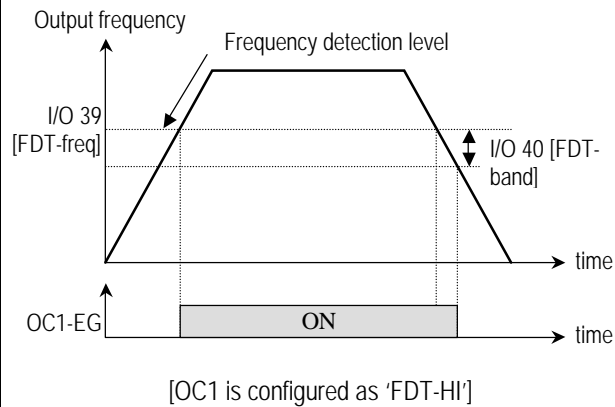

FDT_PULSE:

The output frequency is compared with FDT frequency in I/O 39 [FDT-freq] and FDT band in I/O 40 [FDT-band]. When the output frequency is above the FDT frequency, the output is pulsed on for 100msec. The output is pulsed again for 100msec when the output frequency goes below the FDT frequency minus the FDT band.

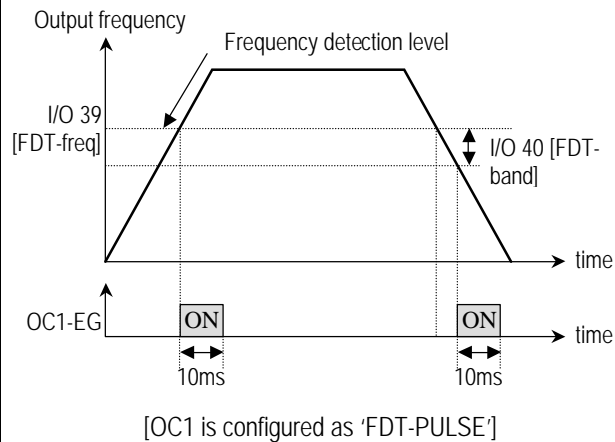

FDT_BAND:

The output frequency is compared with FDT frequency in I/O 39 [FDT-freq] and FDT band in

I/O 40 [FDT-band]. When the output frequency reaches the band centered on the FDT frequency, the output is turned on. The output is turned off when the output frequency goes outside the FDT band centered on the FDT frequency.

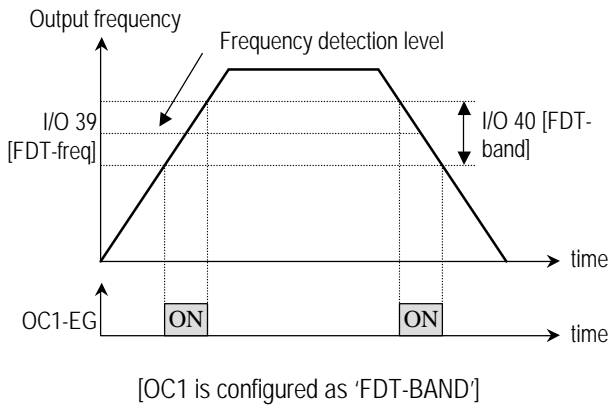

OL: [Overload signal]

If the output current is above the overload warning level set in FUN 47 [OL level] for overload warning duration time set in FUN 48 [OL time], the output signal activates. If the output current then drops below the overload warning level for half of the overload warning duration time, the OL signal will be turned off.

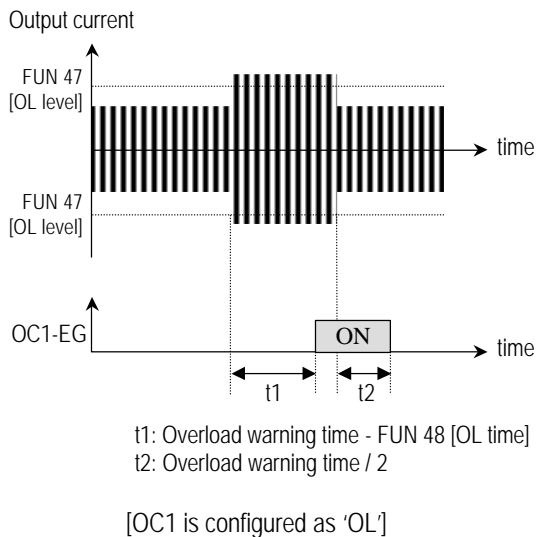

STALL:

This is the signal for a stall condition in acceleration, deceleration or steady state.

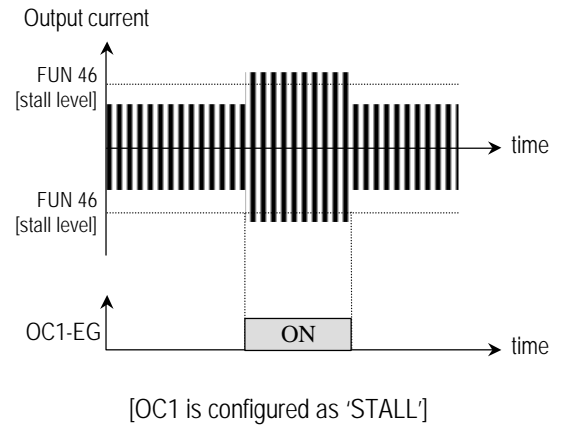

LV: [Low voltage]

This output operates when the inverter's DC link voltage is below the undervoltage level.

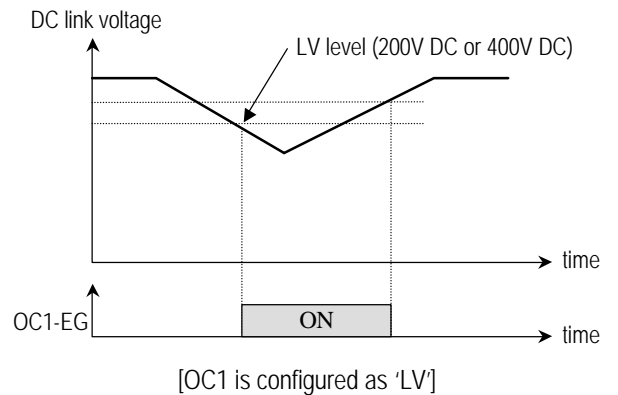

RUN: [On running]

Output signal activates when the inverter is running.

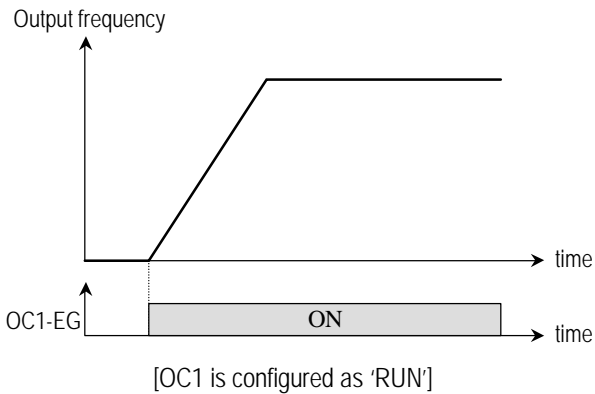

COMM:

Used for the bypass (commercial line exchange) command. See Chapter 8 – Application Notes, section 8.3 – Exchange Inverter to Commercial Line Operation.

STEP_L, STEP_M, STEP_H:

These outputs activate signals in binary format during the multi-step speed drive.

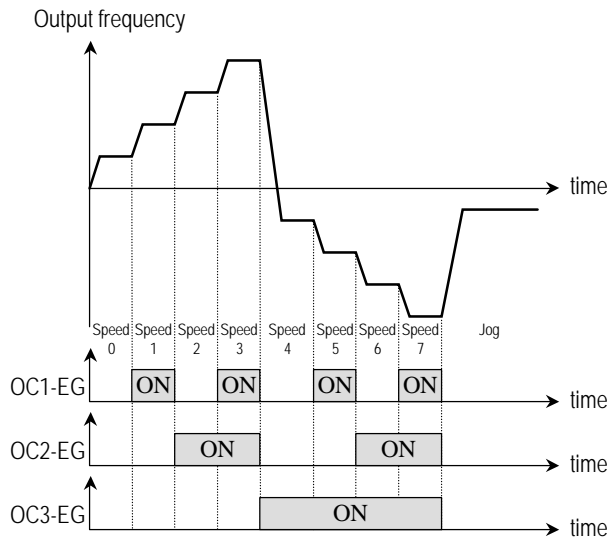

I/O 12: Jog Frequency

Display:

I/O Jog freq.
12 30.00 Hz

Setting Range: 0 to FUN 04

Description:

The jog frequency for inching drive.

Example:

If P4 is defined as 'JOG' in I/O 04 [P4 input] and the jog frequency is set at 5 Hz in I/O 12, the operations are as below.

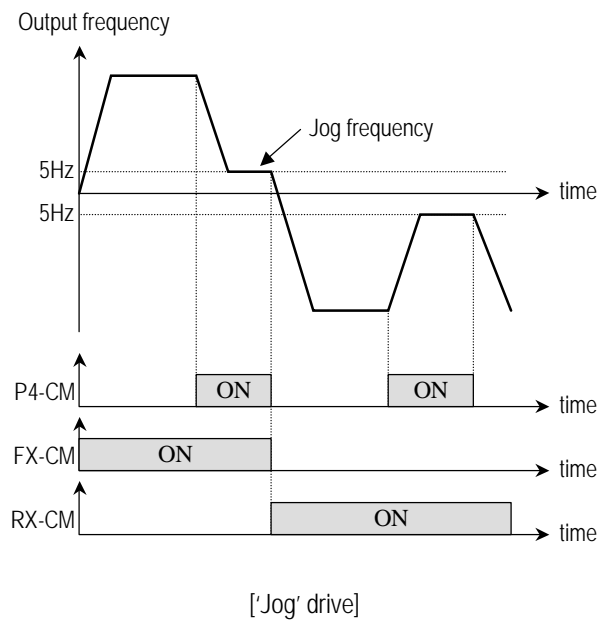

I/O 13 - 19: Multi-step frequency

Display:

I/O# Step freq-1
13 10.00 Hz

⋮

I/O# Step freq-7
19 37.00 Hz

Setting Range: 0 to 400Hz (FUN 04)

Description:

These parameters set the Multi-step speed (frequency) using SPD_L, SPD_M, SPD_H in I/O 1-6 [Multi-function Input definition]. See the 'I/O 1-6 [Multi-function Input definition].

I/O 20 - 33: Multi-Accel/Decel time

Display:

I/O# Acc time-1
20 1.0sec

⋮

I/O# Acc time-7
33 7.0sec

Setting Range: 0 to 6000sec

Description:

These parameters set the Multi-accel/decel time using ACCT_L, ACCT_M, ACCT_H in I/O 1-6 [Multi-function Input definition]. See the 'I/O 1-6 [Multi-function Input definition].

I/O 34 - 35: Load meter (LM terminal)

Display: Load meter selection

I/O# Analog meter
34 Voltage

Setting Range: Voltage, Current

Display: Load meter adjustment

I/O# Analog adj.
35 100 %

Setting Range: 0 to 120%

Description:

The LM terminal on control terminal strip outputs the inverter's output current and voltage with pulse signals. The average voltage ranges from 0V to 10V. For the correct voltage value, adjust I/O 35 [Analog. Adj.].

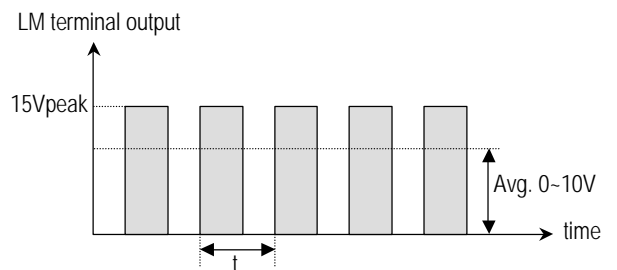

[Load meter (LM-CM terminal) output]

Load meter frequency (1/t) = 1.8kHz (fixed)

Duty(%) =

(output voltage/maximum output voltage)*2/3 or
(output current/trip current)*2/3

Load meter voltage =

(output voltage/maximum output voltage)*10V
or (output current/trip current)*10V

I/O 36: Frequency meter (FM terminal)

Display: Frequency meter adjustment

I/O#	FM adj.
36	100 %

Setting Range: 0 to 120%

Description:

Frequency meter displays the inverter's output frequency with pulse signals on the FM terminal. The voltage ranges from 0V to 10V. To adjust the voltage value, change I/O 36 [FM adj.].

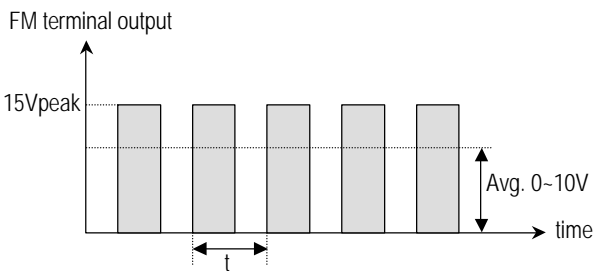

[Frequency meter (FM-CM terminal) output]

Frequency meter frequency (1/t) = (output frequency/maximum output frequency)*1.8kHz

Duty(%) = (output voltage/maximum output voltage)*2/3

Frequency meter voltage = (output voltage/maximum output voltage)*10V

I/O 37: IO meter (4~20mA output)

Display: Digital/Analog conversion adjustment

I/O#	DAC adj.
37	100 %

Setting Range: 0 to 120%

Description:

IO meter displays the inverter's output frequency as a current signal on the IO terminal. The current ranges from 4mA to 20mA. To adjust the current value, change I/O 37 [DAC adj.]. The following equation describes the current output.

IO meter current = 4mA+(output frequency / maximum frequency)*16mA

I/O 38 - 40: Frequency detection level

Display: FST (Frequency steady) level

I/O#	FST-freq.
38	0.05 Hz

Setting Range: 0.5 to 400Hz (FUN 04)

Display: FDT (Frequency detection) level

I/O#	FDT-freq.
39	60.00 Hz

Setting Range: 0.5 to 400Hz (FUN 04)

Display: FDT (Frequency detection) band

I/O#	FDT-freq.
40	1.00 Hz

Setting Range: 0.5 to 30 Hz

Description:

These parameters are used in Multi-function output. For more detailed description, see the Multi-function outputs in I/O 07 – 11.

I/O 41 - 42: Speed display factor

Display: Multiplier factor

```
I/O☞ Mul factor
41          100
```

Setting Range: 0 to 999

Display: Divide factor

```
I/O☞ Div factor
42          100
```

Setting Range: 1 to 999

Description:

The speed display of DRV 04 can be translated to line speed. Motor poles should be entered in FUN 54 [Motor pole] for correct speed display.

$$\text{Line Speed} = \frac{\text{Multiplier factor}}{\text{Divide factor}} \times \frac{120 \cdot \text{output freq.}}{\text{Motor pole}}$$

I/O 43 - 44: Status of I/O terminals

Display: Status of Input terminals

```
I/O☞ Ter. input
43          1000000001
```

Display: Status of Output terminals

```
I/O☞ Ter. output
44          10001
```

Description:

The status of terminals FX, RX, P1 – P6 and output terminals OC1, OC2, OC3, AUX1 (1A, 1B) and AUX2 (2A, 2B) can be viewed.

Input Terminal Status

P6	P5	P4	P3	P2	P1	X	X	RX	FX
1	0	0	0	0	0	0	0	0	1

Output Terminal Status

AUX2	AUX1	OC3	OC2	OC1
1	0	0	0	1

I/O 45: Software version

Display: S/W version display

```
I/O☞ S/W version
45          1.00H
```

Description:

View the software version.

I/O 46 - 47: Display past trip information

Display: The first tip information

```
I/O☞ Last fault 1
46          OV Trip
```

Display: The second trip information

```
I/Oϕ°Last fault 2
47      OC Trip
```

Description:

Review of trip information.

Example:

By using the PROG, UP and DOWN arrow key, old trip information (which contains current, frequency and trip) can be viewed.

```
I/Oϕ°Last fault 1
46      OV Trip
```

```
I/Oϕ°Last fault 1
46      35.60 Hz
```

```
I/Oϕ°Last fault 1
46      16.5 A
```

```
I/Oϕ°Last fault 2
47      OC Trip
```

```
I/Oϕ°Last fault 2
47      60.00 Hz
```

```
I/Oϕ°Last fault 2
47      50.6 A
```

I/O 48 - 49: Option selection

Display: The first option selection

```
I/Oϕ° Option 1
48      None
```

Display: The first option selection

```
I/Oϕ° Option 2
49      None
```

Setting Range:

- None
- RS485
- PG
- DI/DA
- PLC
- CAN

Description:

Select of add-on Option cards.

RS485: [RS485 communication card]

Communicates between the inverter and a computer using an ASCII protocol. For more detailed information, refer to RS485 option manual.

PG: [Pulse Generator card]

Speed control can be achieved with encoder feedback. Refer to PG option manual.

DI/DA:

With this option, the inverter gets its reference frequency from a 12-bit digital input. Also, it is possible to get a 4-20mA output signal of the inverter's output voltage or output current. For more detailed information, refer to DI/DA option manual.

PLC:

This function allows a PLC to communicate with the inverter by high speed (1Mbps). Refer to PLC option manual.

CAN:

This option makes it possible to communicate between two inverters. More detailed information is available in the CAN option manual.

I/O 50: Inverter ID number (Option)**Display:**

I/O# Inv. number
50 1

Setting Range: 1 to 32**Description:**

This is the inverter's unique ID number. It is used for the RS485 and CAN option.

I/O 51: Baud rate (Option)**Display:**

I/O# Baud-rate
51 9600 BPS

Setting Range: 1200, 2400, 4800, 9600, 19200**Description:**

This is the communication speed between the inverter and computer. It is used with the RS485 communication option.

I/O 52: Comm timeout (Option)**Display:** Communication timeout

I/O# Comm. Timeout
52 10.0sec

Setting Range: 0 to 60sec**Description:**

This used only with the RS485 communication option.

I/O 53: PG slip frequency (Option)**Display:**

I/O# PG Slip Freq
53 5.00 Hz

Setting Range: 0 to 10Hz**Description:**

When using the PG option, this parameter sets the PG's slip frequency.

I/O 54: PG P-gain (Option)**Display:**

I/O# PG. P-Gain
54 10

Setting Range: 0 to 255**Description:**

This is only used with the PG option. It is the PG option's proportional gain.

I/O 55: PG I-gain (Option)**Display:**

I/O# PG. I-Gain
55 30

Setting Range: 0 to 255**Description:**

This is only used with the PG option. It is the PG option's integral gain.

I/O 56: PG filter gain (Option)

Display:

I/O#° PG. F-Gain
56 100

Setting Range: 0 to 255

Description:

The PG filter gain works with the PG option.

I/O 57: Encoder pulse number (Option)

Display:

I/O#° Enc pulse
57 512 Pulse

Setting Range: 100, 500, 512, 1000, 1024, 2000, 2048, 4000 pulse

Description:

The PG filter gain works with the PG option.

I/O 58: Digital Input (Option)

Display:

I/O#° DI Mode
58 None

Setting Range: None, Freq. 1, Freq. 2

Description:

Only for DI/DA option. This selects the type of 12-bit digital input.

I/O 59: Analog Output (Option)

Display:

I/O#° DA Mode
59 Freq.

Setting Range: Freq., Voltage, Current

Description:

This function is used with the DI/DA option. The output voltage or current of the inverter is output as a 4-20mA analog signal.

I/O 60: Analog output adjustment (Option)

Display:

I/O#° DA adj.
60 100 %

Setting Range: 80 to 120%

Description:

This function is used with the DI/DA option.

◆ Parameters in I/O 48 – 60 are all option related. Please refer to their option manual for detail description.

CHAPTER 6 - ADVANCED FEATURES

6.1 Acceleration / Deceleration

6.1.1 Via Keypad

DRV 01: Acceleration Time

DRV 02: Deceleration Time

Operator can program the acceleration and deceleration times via keypad of ACtionMaster Series H drive into the above parameters.

FUN 56: Acceleration Time during Speed Search

FUN 57: Deceleration Time during Speed Search

I/O 5 to I/O 6: Multi-function Input Selection (select **SS**)

These acceleration and deceleration times are used when the speed mode is selected via one of the multi-function input terminals (**P1** through **P6**). Also, refer to speed search.

DRV ϕ ° Acc. Time
01 30.0 sec

DRV ϕ ° Dec. Time
02 60.0 sec

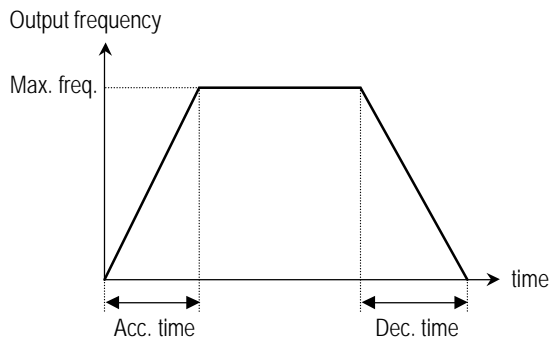

6.1.2 Via Terminal

I/O 20 to I/O 33: Multi-Step Accelerations and Decelerations

Using the multi-function input terminals P1 – P6 (**I/O 01** to **I/O 06**) and/or with the multi-step frequencies (**I/O 13** to **I/O 19**) defined, separate Accel/Decel times can be set for each step. When P4, P5, P6 are set to ACCT_L, ACCT_M, ACCT_H respectively, the operating sequence is as following figure.

Multi-Accel / Decel time selections by Multi-function Input Terminals

Terminal	Time 0	Time 1	Time 2	Time 3	Time 4	Time 5	Time 6	Time 7
ACCT_L	0	1	0	1	0	1	0	1
ACCT_M	0	0	1	1	0	0	1	1
ACCT_H	0	0	0	0	1	1	1	1

0: inactive (off), 1: active (on)

The Time 0 Accel/Decel time is configured by DRV 01-02 and selected when no Accel/Decel input terminals are active. The Time 1-7 Accel/Decel times are set in I/O 20-33.

Example:

If P4 is configured as ACC_L, P5 as ACCT_M and P6 as ACCT_H, then the transition time can be selected by P4, P5 and P6 terminals.

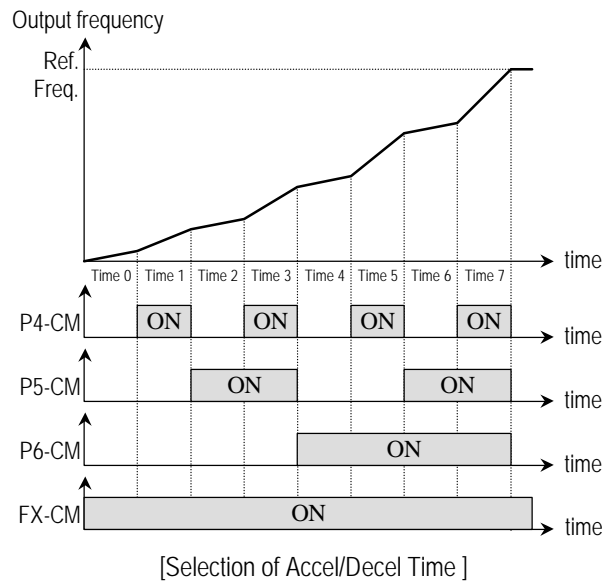

6.2 Auto-Restart / Speed Search

6.2.1 Auto-Restart

FUN 42: Retry Number

FUN 43: Retry Time

FUN ϕ °Retry number	FUN ϕ ° Retry time
42 0	43 1.0sec

These functions are used to allow the drive to reset itself automatically from a various drive faults (Overvoltage, Overcurrent, Ground Fault, Torque Limit Fault, etc.). ‘Under Voltage’ or ‘BX’ fault can NOT be automatically reset. The operator can set the maximum number of auto-restart trials through **FUN 42**. Retry Time (a waiting time before the next restart attempt) is set through **FUN 43**. The auto-restart works in conjunction with the Speed Search mode.

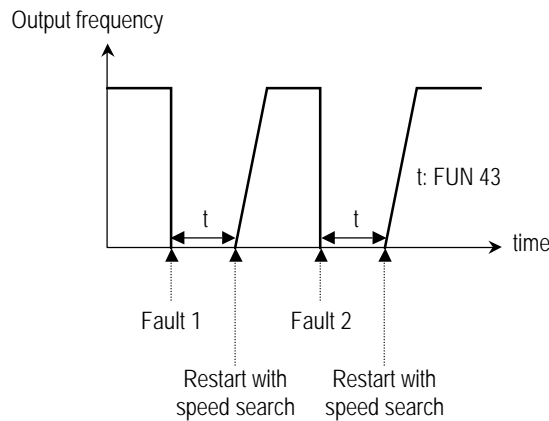

6.2.2 Speed Search

The Speed Search mode is used when the drive needs to be restarted in to a motor that is coasting. This function is especially important if the motor has a large load inertia.

Without speed search, restarting into a coasting motor can result in an Overcurrent fault.

INSTANTANEOUS POWER FAILURE

FUN 55: IPF select – IPF Restart Selection

FUN 56: SS acc. time – Speed Search Accel Time

FUN 57: SS dec. time – Speed Search Decel Time

FUN 58: SS gain – Speed Search Gain

This function is used to initiate the automatic restart mode after an Instantaneous Power Failure of over 15 milliseconds in duration. As the drive resets itself from IPF, it waits for the amount of time programmed in **FUN 58** before it starts to search for the current speed of the coasting motor. Once the current speed of the motor is determined, the drive then accelerates (**FUN 56, FUN 57**) to the previous set frequency reference. Speed Search Gain and acc/dec time for the Speed Search mode must be set while considering the inertia moment and the magnitude of torque demand of the load.

FUN ϕ IPF select 55 --- No ---	FUN ϕ ss acc. time 56 5.0sec
FUN ϕ ss dec. time 57 10.0sec	FUN ϕ ss gain 58 100 %

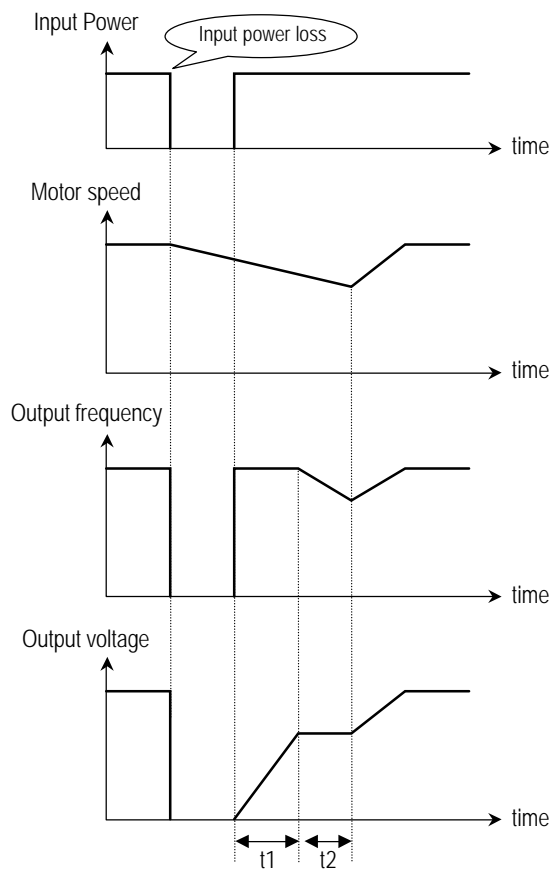

t1: FUN 56 [ss acc. time]

t2: FUN 57 [ss dec. time]

[IPF restart and Speed Search]

RESTART AFTER RESET

FUN 59: Restart after Fault Reset

When RST-restart is set to 'YES', the drive can be selected to have itself initiate auto-restart mode after the manual reset. If this parameter is set to 'NO', then the drive needs to receive the 'RUN' command after the manual reset.

FUN#	RST-restart
59	--- No ---

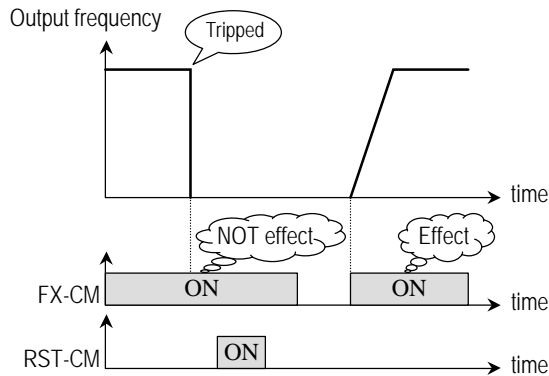

[Reset restart: 'No']

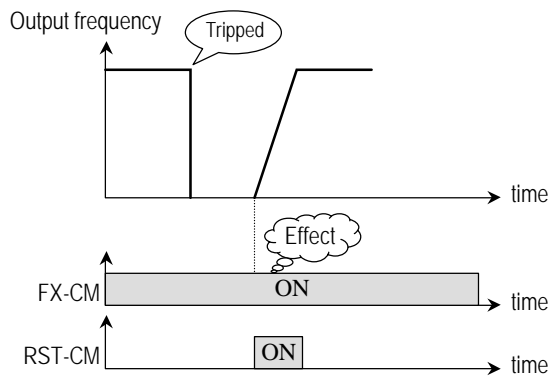

[Reset restart: 'Yes']

INPUT POWER DETECTED AUTO-RESTART

FUN 60: Power on st – Restart after Power Up Sequence

If the input power is restored with either the FX input terminal (run forward) or RX input terminal (run reverse) closed to common, the drive will initiate the auto-restart automatically when **FUN 60** is set to 'YES'.

FUN ϕ ° Power on st		
60	---	No ---

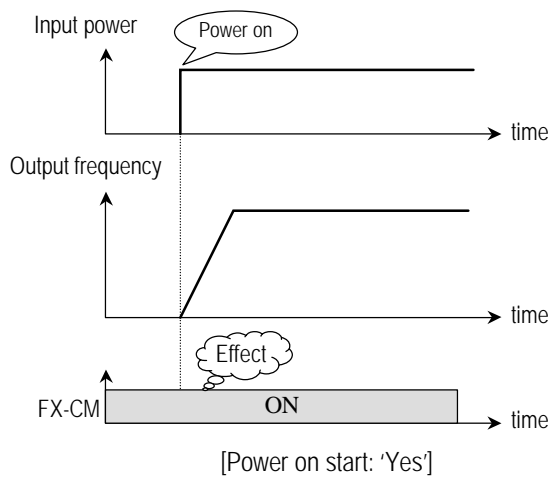
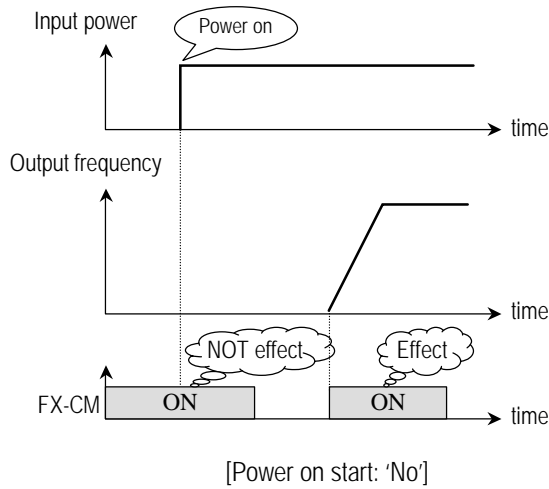

6.3 D.C. Injection Braking

- FUN 33:** DC Injection Braking Frequency
- FUN 34:** DC Injection Braking On-Delay Time
- FUN 35:** DC Injection Braking Time
- FUN 36:** DC Injection Braking Voltage
- FUN 15:** Stop pattern selection (must be set to **DCBR**)
- I/O 01 – I/O 06:** Multi-function Input (one of P1 – P6: **EXT_DCBR**)

This function can be used to bring the motor to a quick stop **without** the use of dynamic braking resistors. **FUN 33** sets the starting frequency where the DC injection begins. **FUN 34** is the time between the DC Injection command and the actual desired moment of DC injection output. **FUN 35** is the total braking time. **FUN 36** is the level of DC injection voltage output (% of rated). The DC injection braking can be selected by selecting DCBR in **FUN 15**. Also, one of the multi-function input terminals can be used to trigger the DC injection braking by designating a terminal to be EXT_DCBR. (See section 6.11 Multi-Function Inputs). This method also is used to hold the motor at zero speed for a short period of time.

- FUN ϕ DC-br freq
 33 0.5 Hz
- FUN ϕ DC-br block
 34 2.0 sec
- FUN ϕ DC-br time
 35 0.5 sec
- FUN ϕ DC-br value
 36 1 %
- FUN ϕ Stop mode
 15 Decel

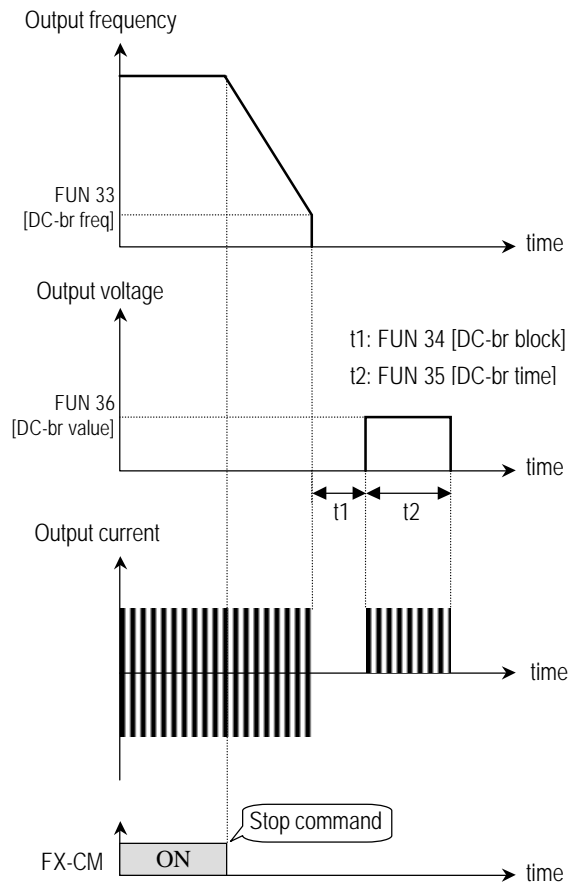

6.4 Drive Protection

6.4.1 Overload Warning

FUN 47: Overload Warning Level

FUN 48: Overload Warning Time

I/O 07 – I/O 11: Multi-function Output (one of OC1-OC3, AUX Relay:**OL**)

This function is used to provide a motor overload warning. When the output current of the drive has reached the value of FUN 47, a designed multi-function output terminal will be turned on. However, for a ‘Overload’ fault trip to occur, **FUN 49** and **FUN 50** must be set to desired value.

FUN ϕ OL level	
47	150 %

FUN ϕ OL time	
48	10.0sec

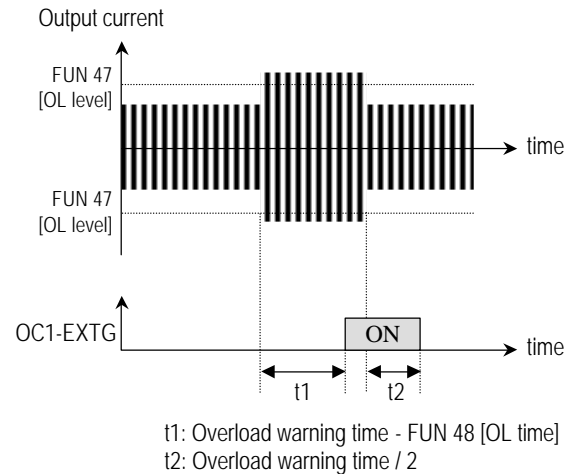
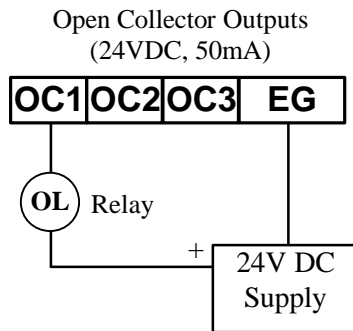

[Overload warning: when OC1 is configured as 'OL']

6.4.2 Overcurrent Limit Trip

FUN 49: Over-Current Limit Level

FUN 50: Over-Current Limit Time

FUN ϕ OC lim level	
49	160 %

FUN ϕ OC lim. time	
50	60.0sec

When the output current of the drive has reached the value of **FUN 49** for a continuous time set in **FUN 50** due to an excessive load, the **O.C.** (Overcurrent Fault) will occur and the motor will coast to a stop. In constant torque range, this overload limit can be set to 150% for a period of 60 seconds duration. In variable torque range, the overload limit can be set up to 120% for 60 seconds of duration.

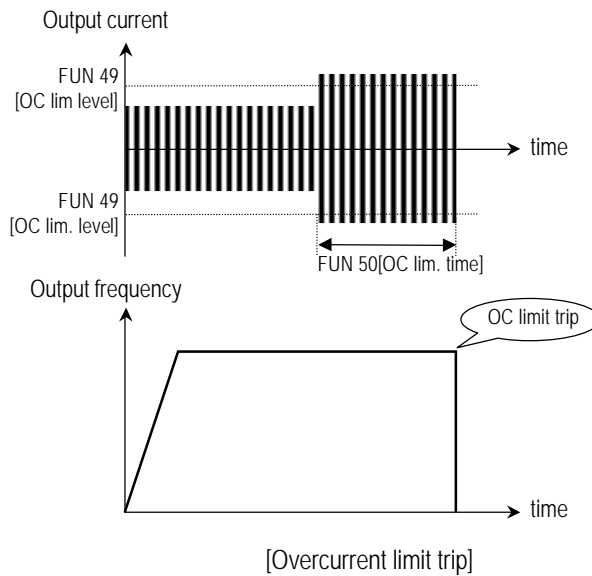

6.4.3 Electronic Thermal Detection

FUN 51: ETH Selection

FUN 52: ETH Thermal Level

FUN 53: Motor Type Selection

FUN ϕ	ETH select
51	--- No ---

FUN ϕ	ETH level
52	150 %

FUN ϕ	Motor type
53	General

This function is used to compensate for excessive motor heat generated during low frequency operation. This is especially true of the capacity of the motor is lower than that of the inverter. To prevent the motor from overheating, the ETH level must be set according to the provided formula.

$\text{ETH Level (\%)} = K \times \frac{\text{Motor rated current}}{\text{Inverter rated current}} \times 100$
--

If 50 Hz input power, K = 1.0
 If 60 Hz input power, K = 1.1

Once the ETH level is found, then the motor type must be determined. There are two electronic thermal characteristics, one is a 'General' pertaining to a standard AC induction motor, the other is 'Special' for a special motor containing a blower.

Once the correct values are programmed, the drive will determine the ETH time for either the General or Special motor per below.

For a General motor,

$$\text{ETH time} = 60 \times ((\text{motor rated current} \times \text{output frequency} \times \text{ETH level}) / (\text{output current} \times 60\text{Hz} \times 100))$$

For a Special motor,

$$\text{ETH time} = 60 \times ((\text{motor rated current} \times \text{ETH level}) / (\text{output current} \times 100))$$

6.4.4 Stall Prevention

FUN 45: Stall Prevention Selection

FUN 46: Stall Prevention Level

FUN ϕ ° Stall mode
45 None

FUN ϕ ° Stall level
46 150 %

These functions are used to prevent the motor from stalling by reducing the inverter output frequency until the motor current level decreases below the stall prevention level.

Once the motor current level satisfies the value of **FUN 46**, then the drive will increase its output frequency to its set point.

■ ACC

If the output current of the drive has reached the stall prevention level during acceleration, the drive will stop accelerating until the current level is reduced below **FUN 46** before it resumes acceleration to a set frequency command.

■ STEADY

If the output current of the drive has reached the stall prevention level during the steady speed running period due to load fluctuation, the drive will reduce its output frequency until the output current level is reduced below **FUN 46**. The drive will then increase its output frequency to a set frequency command.

■ DEC

If the DC BUS voltage reaches the overvoltage fault level during deceleration, the drive will stop further deceleration.

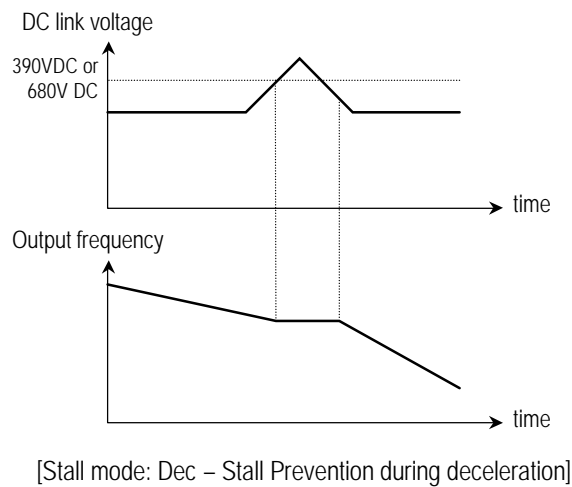
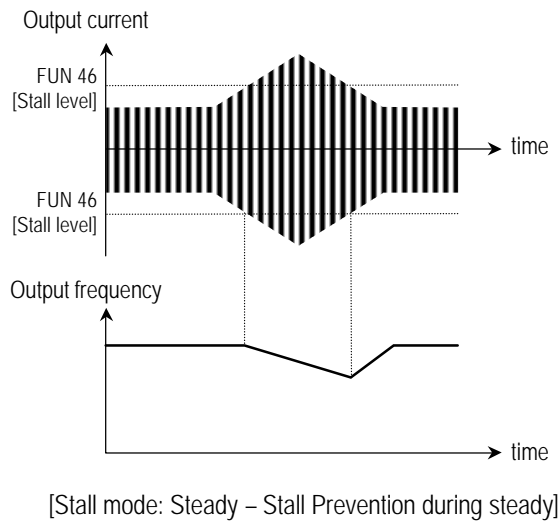
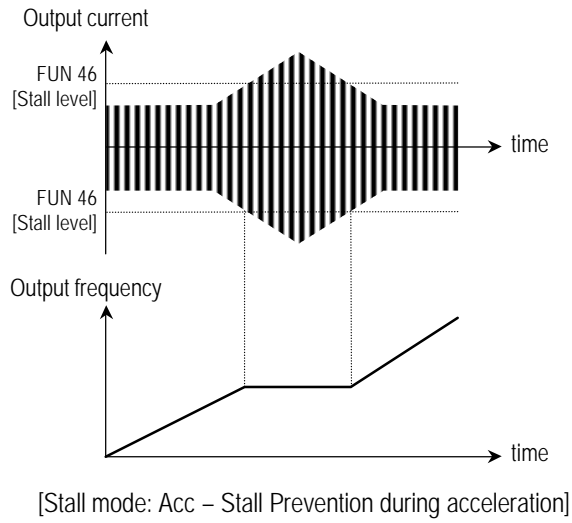

6.5 Energy Saving

FUN 14: Energy Saving Level

FUN#	Energy save
14	100 %

There are several ways to control the flow of a fan or pump including inlet valves and outlet dampers. Due to the 'Affinity Law', these methods are not particularly energy efficient. In the case of an outlet damper, there is only a 5% drop of input power demand when the flow reduces from 100% to 80%. In a centrifugal fan application, the 'Energy-Output Speed' relation is not linear but square. The required power by the load is proportional to the square of the motor speed.

For example, a pressure sensor detects the air pressure level, and sends the signal to a pressure-current transducer, which then feeds a 4 to 20mA signal to the blower drive. This causes the ACtionMaster-Series H to reduce its output voltage to the value set in **FUN 14** and still maintain the same thermal state. This results in less energy consumption.

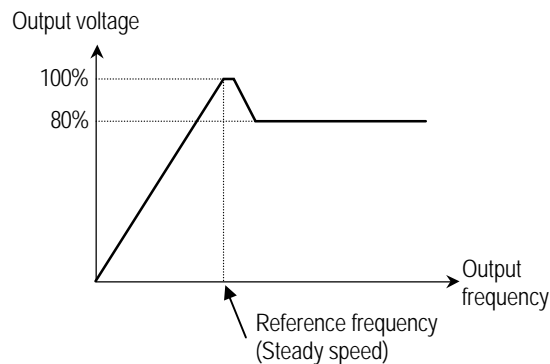

[When Energy save level set at 80%]

6.6 Frequency Reference

6.6.1 Via Keypad

- DRV 00:** Frequency Reference Setting
- DRV 01:** Freq. Reference Source Selection
- FUN 04:** Maximum Frequency Setting
- FUN 05:** Base Frequency Setting
- FUN 06:** Starting Frequency Setting

FUN ϕ Freq. set 01 Key	FUN ϕ Freq. max 04 60.00 Hz
FUN ϕ Freq. base 05 60.00 Hz	FUN ϕ Freq. start 06 60.00 Hz

The drive command frequency in DRV 00 can be set via the keypad by selecting 'Key' in **FUN 01**. The value of DRV 00 will be limited by the value of the **Maximum Frequency** set in **FUN 04**. Generally, the maximum frequency is set either to the maximum motor output speed of an operator-desired value. The **Base Frequency** is the motor rated speed in the constant torque range. This base frequency value should not be set higher than that of **FUN 04**. If the base frequency is set at 60Hz and the maximum frequency is set at 120Hz, the motor will run up to 60Hz in constant torque mode and up to 120Hz in constant horse power mode.

The **Start Frequency** set in **FUN 06** provides the initial frequency output of the drive. Setting this value too high can result in an increased starting torque demand, which might cause an 'Overcurrent' Fault.

Note: When the Maximum Frequency setting is changed, all of the above parameters must be modified for correct motor operation.

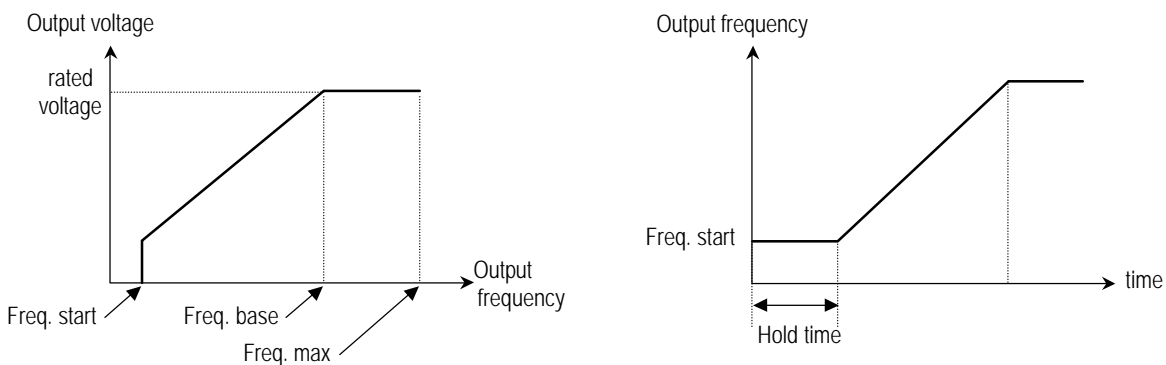

FUN 25: Frequency Limit Selection

FUN 26: High Limit Frequency

FUN 27: Low Limit Frequency

By selecting 'Yes' in **FUN 25**, the output frequency range of the drive is limited to values set in **FUN 26** and **FUN 27**.

FUN ϕ Freq. limit	FUN ϕ F-limit high	FUN ϕ F-limit low
25 --- No ---	26 60.00 Hz	27 0.00 Hz

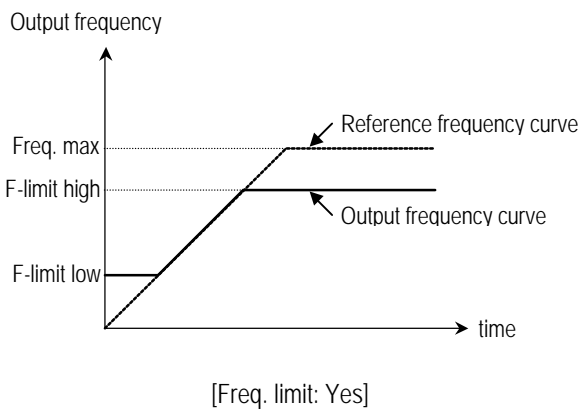

6.6.2 Reference Frequency via Analog Input Terminal

FUN 01: Frequency Reference Source Selection

FUN 20: Analog Frequency Reference Selection

FUN 21: Analog Input Filter Gain

FUN 22: Analog Input Scaling

FUN 23: Analog Input Bias

FUN 24: Analog Input Direction

In order for the drive to receive its frequency reference from an external source, **FUN 01** must be set to 'Terminal'. **FUN 20** is used to select the analog frequency reference method. If a 0 to 10VDC signal is the source of reference, then 'V1' should be selected. If a 4 to 20mA signal is the source of reference, then 'I' should be selected. When both of the signals are used, then 'V1+I' should be selected.

When the PI control function is used, the value in **FUN 01** will be ignored. The 0 to 10VDC signal becomes the frequency reference, and 4 to 20mA becomes the feedback signal. (also refer to section 6.15 P.I. Control)

Chapter 6 - Advanced Features

The Analog Input Filter Gain setting in **FUN 21** can be adjusted to set the responsiveness of the drive output. For example, to obtain a faster response, the gain in **FUN 21** is set to a lower value and vice versa.

FUN ϕ	V-I mode
20	V1

FUN ϕ	Filter gain
21	50 %

FUN ϕ	Analog gain
22	100 %

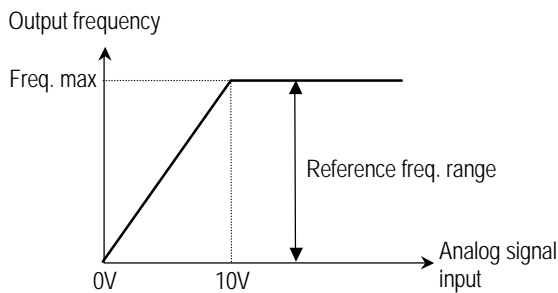

[V-I mode: V1 (Voltage 1)]

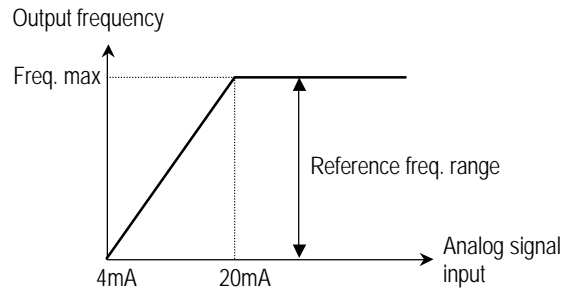

[V-I mode: I (Current)]

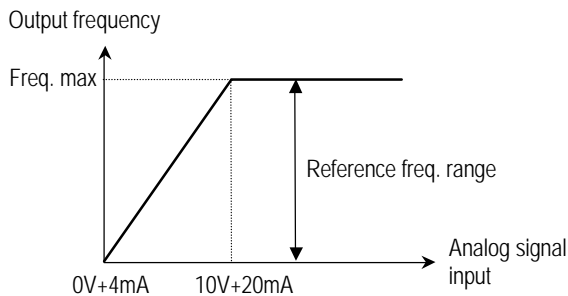

[V-I mode: V1+I (Voltage 1+Current)]

The Analog Input Scaling in **FUN 22** is used to set the correct ratio of the analog input signal to its maximum frequency reference of the drive. For example, if the drive needs to accept a +5VDC analog signal as its maximum frequency reference instead of +10VDC, setting **FUN 22** to '50%' the drive will calculate its maximum analog input by ' $10\text{VDC} * \text{FUN } 22(0.5) = 5\text{VDC}$ '. This setting will prepare the drive to understand +5VDC input signal as its maximum frequency reference.

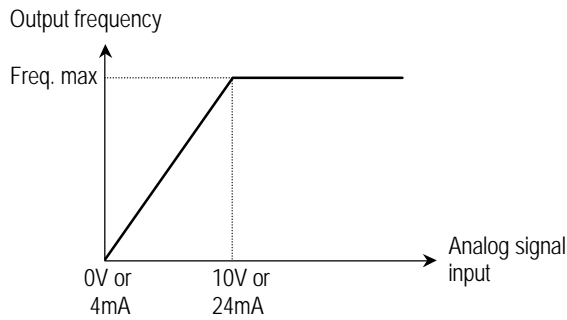

[FUN 22 = 100%]

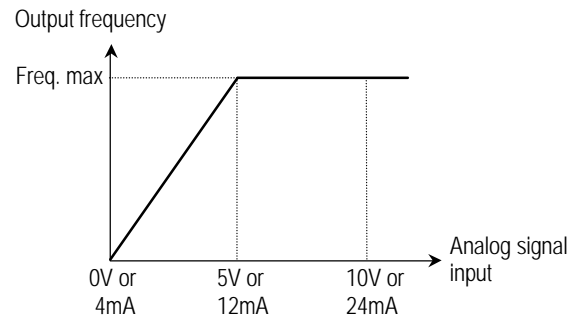

[FUN 22 = 50%]

If **FUN 22** is used to set the ratio between the ‘Maximum analog input signal’ and the ‘Maximum frequency reference’, **FUN 23** is used set the ratio between the ‘Maximum analog input signal’ and the ‘Maximum frequency reference’.

FUN ϕ Analog bais
23 0 %

FUN ϕ Analog dir
24 Direct

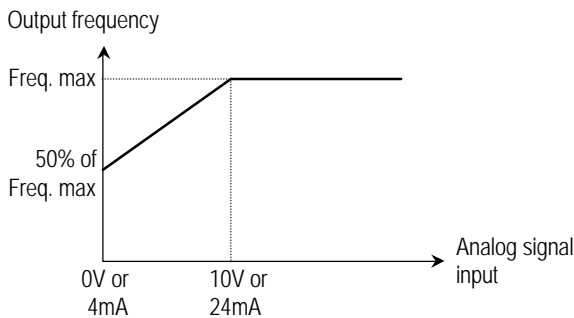

[FUN 23 = 50%]

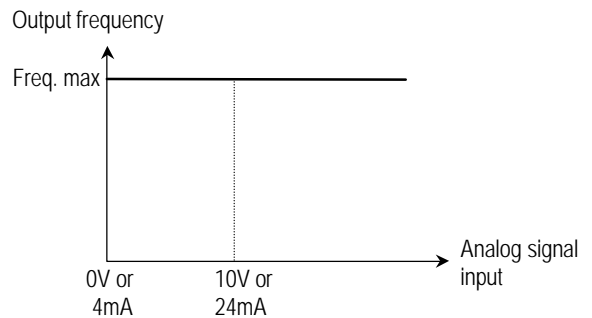

[FUN 23 = 100%]

The value set in **FUN 24** will determine the Analog Input vs. Frequency Reference slope to be either a positive or negative slope linear ratio. When set to ‘**Direct**’, the analog command signal (0 – 10VDC or 4 – 20mA) represents increasing positive slope. When set to ‘**Invert**’, then the signal (0 – 10VDC or 4 – 20mA) represents decreasing negative slope.

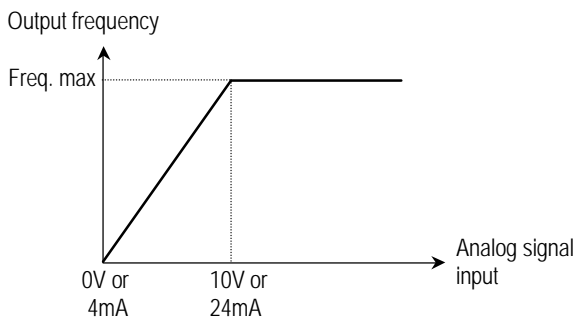

[FUN 24 = Direct]

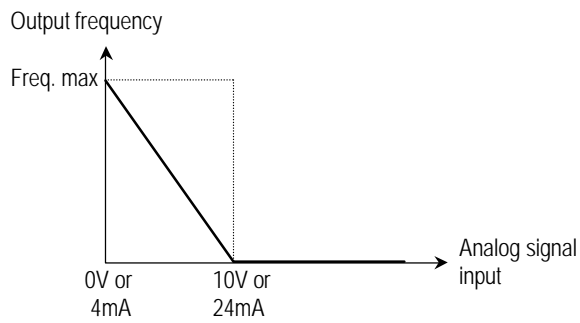

[FUN 24 = Invert]

6.6.3 Frequency Reference via Multi-Step Input

I/O 01 – I/O 06: Multi-function Input Terminal (SPD_L, SPD_M, SPD_H)
I/O 13 – I/O 19: Step Frequency Setting

The drive can be pre-programmed to follow up to 7 different steps of frequency reference. Each of the steps can be initiated by connecting the ‘Multi-function Input’ terminals to the ‘Common’ terminal. Each step frequency setting corresponds to one of the 7 steps (via SPD_L, SPD_M, SPD_H).

Example:

The drive needs to have 7 different step speed reference value. We would like to program terminal P1 through P3 to become SPD_L, SPD_M and SPD_H. The drive must be programmed as below:

I/O 01 = SPD_L (Set P1 to SPD_L)

I/O 02 = SPD_M (Set P2 to SPD_M)

I/O 03 = SPD_H (Set P3 to SPD_H)

This is actually a binary number. IF SPD_L = 0, SPD_M = 1 and SPD_H = 0 (terminal P1 = open, P2 = closed and P3 = open), then this represents step 2 (010) in binary form. The speed reference value set in **I/O 13 – I/O 19** will be the drive speed reference for that particular step.

Please refer to Multi-Function Inputs in Section 6.11 in this chapter.

6.6.4 Frequency Reference Via DI/DA (Digital Input/Analog Output) Option Card

I/O 58: DI mode

I/O#	DI Mode
58	None

This function is used to configure the ‘DI’ option card to accept a 12-bit Digital Input. Refer to Option Card instruction sheet.

6.7 Frequency Jump

FUN 28: Frequency Jump Selection

FUN 29: Jump Frequency 1

FUN 30: Jump Frequency 2

FUN 31: Jump Frequency 3

FUN 32: Bandwidth of Jump Frequency

FUN ϕ Freq. jump
28 --- No ---

FUN ϕ Freq-jump 1f
29 10.00 Hz

FUN ϕ Freq-jump 2f
30 20.00 Hz

FUN ϕ Freq-jump 3f
31 30.00 Hz

FUN ϕ Freq. band
32 5.00 Hz

Undesirable resonance and vibration on the motor shaft can occur within a certain frequency range due to the structure of a machine. This jump function is used to lock that frequency band out of the operation. Most of the time, this phenomenon occurs only at a specific frequency. The jump frequency bandwidth is the span of the jump frequencies selected. The three jump frequencies share one bandwidth. To use just one of the three jump frequencies, the other must set to zero.

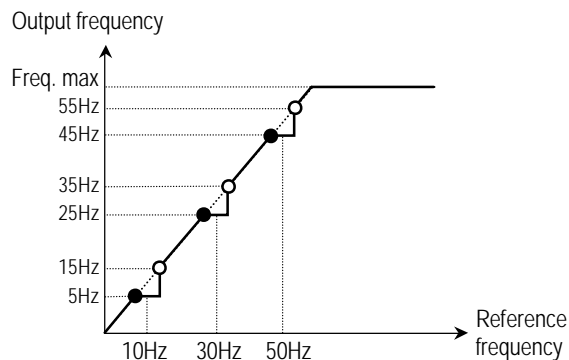

- **Note:** When the reference frequency is set inside the jump frequency, the output frequency goes to the frequency marked by “●” symbol.

6.8 Frequency Output Monitor

The drive frequency can be monitored via keypad, analog output card and multi-function output terminals.

6.8.1 Via Keypad

DRV 00: Drive Output Frequency

```
DRV $\phi$  Manual K/K  
00 FWD 60.00 Hz
```

The keypad displays the drive frequency output to the motor once the RUN command is initiated. When the speed feedback card is installed, the frequency display is the actual motor speed. However, when the drive is running in open loop (no feedback card), the frequency output displayed on the keypad is the output frequency of the inverter which is not necessarily the exact motor speed. When the drive is not in RUN mode, the frequency display indicates the programmed frequency reference.

6.8.2 Via Analog Output Card

I/O 59: Analog Output

```
FUN $\phi$  RST-restart  
59 --- No ---
```

In order to use this function, a DI/DA option card must be installed in the drive. With the option card installed, I/O 59 should be set to 'Frequency' for frequency output on the 4-20mA analog signal.

*Follow the Option Card Instruction.

6.8.3 Via Frequency Meter Terminal

I/O 36: Frequency Meter Adjustment (15V pulse)

```
I/O $\phi$  FM adj.  
36 100 %
```

The frequency meter puts the drive output frequency in a pulsed output (Pulse-width Modulation) on the FM terminal. The voltage of this PWM output ranges from 0V to 10VDC, and can be adjusted via setting of **I/O 36**. For example, **I/O 36 = 100%** will result in 10VDC through the FM output terminal when the drive output frequency is at 100% of its speed reference. The value of **I/O 36 = 10%** will result in 1VDC accordingly. The equations below are for reference only, and aid in the understanding of the PWM output.

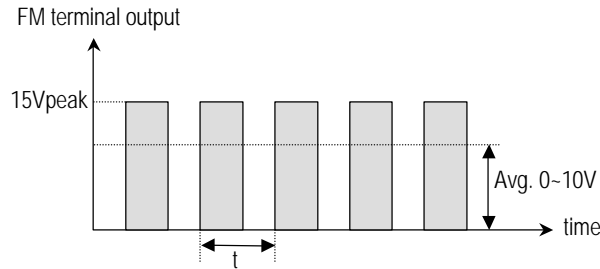

[Frequency meter (FM-CM terminal) output]

Frequency meter frequency (1/t) =

$$\left(\frac{\text{output frequency}}{\text{maximum output frequency}}\right) * 1.8\text{kHz}$$

Duty (%) = $\left(\frac{\text{output voltage}}{\text{maximum output voltage}}\right) * 2/3$

Frequency meter voltage =

$$\left(\frac{\text{output voltage}}{\text{maximum output voltage}}\right) * 10\text{V}$$

6.8.4 Via IO (Analog Output) Terminal

I/O 37: IO Meter Adjustment (4-20mA)

I/O 37	DAC adj.
37	100 %

The frequency meter puts the drive output frequency as a current signal on the IO terminal. The current ranges from 4mA to 20mA, and can be adjusted via setting of **I/O 37**. Or example, **I/O 37 = 100%** will result in 20mA through the IO output terminal when the drive output frequency is at 100% of its speed reference. The value of **I/O 37 = 10%** will result in 5.6mA accordingly. The equations below are for reference only, and aid in the understanding of the 4-20mA output.

Frequency meter current = 4mA + (Output frequency / Maximum frequency) * 16mA

6.9 Jog

I/O 01 – I/O 06: Multi-function Input Terminal (set to **JOG**)

I/O 12: Jog Frequency

I/O#	Jog freq.
12	30.00 Hz

One of the six multi-function terminals (P1 through P6) can be configured to be a ‘Jog’ switch. For example, to set P4 to be a Jog button, **I/O 04** must be set at **‘JOG’**. This function can be used to inch the drive forward or reverse.

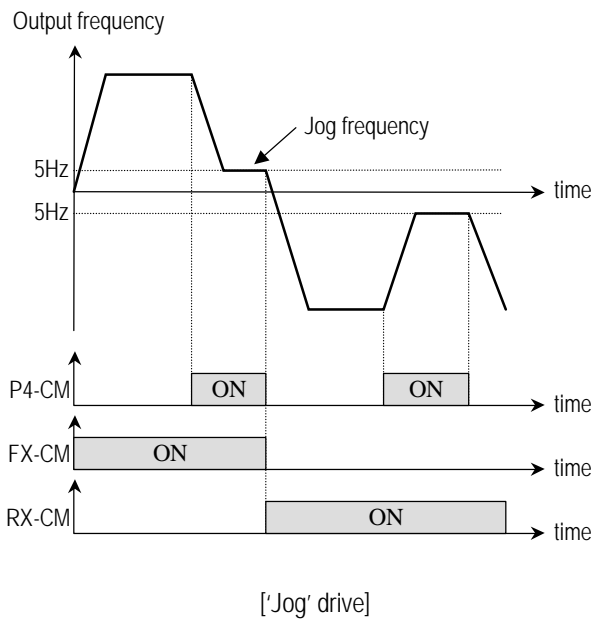

6.10 Motor Data

In order for the drive to operate the motor accurately, the name plate data of the motor must be programmed in correctly. Without this data, the drive output torque can be maximized and motor overheating could occur in some instances.

FUN 37: Slip Compensation Selection

I/O ϕ ^o	DAC adj.
37	100 %

This function is selected to reduce the motor slip. The slip refers to the drop in the motor RPM due to a motor load. By selecting this function, the drive will output a frequency which results in true synchronous motor instances.

FUN 38: Rated Slip of the Motor

FUN 39: Rated Current of the Motor

FUN 40: No load Current of the Motor

I/O ϕ ^o	FST-freq.
38	0.05 Hz

I/O ϕ ^o	FDT-freq.
39	60.00 Hz

I/O ϕ ^o	FDT-freq.
40	1.00 Hz

* Slip Compensation Frequency

$$\text{Delta Frequency} = \frac{\text{Output current} - \text{No load current}}{\text{Rated current} - \text{No load current}} \times \text{Rated slip}$$

6.11 Multi-Function Inputs

I/O 01 - I/O 06: Multi-function Input Terminal Selection

The ACtionMaster Series H has a total of 6 programmable input terminals (P1 through P6). Each one of these can be defined for several different applications. The table below describes the definition of each function.

Multi-function Input Terminal Selection Table

I/O 01 - I/O 06 Choices	Definition
SPD_L SPD_M SPD_H	Multi-step speed via P1 - P6. SPD_L is the lowest bit. ex) 001 = step1, 101 = step 5
JOG	Jog
ACCT_L ACCT_M ACCT_H	Multi-accel/decel Time selection. ACCT_L is the lowest bit. ex) 001 = acc/dec time 1
UP	Increase the drive frequency output.
DOWN	Decrease the drive frequency output.
HOLD	Hold the current drive output frequency.
OPT_MAN	Reserved
COMM_CON	Initiate the Commercial Line Exchange.
EXT_DCBR	Initiate the Dynamic Braking Mode.
EXT_TRIP	Initiate the External Fault.

6.11.1 SPD_L, SPD_M, SPD_H

Any of the three 'Multi-function Input Terminals' (P1 through P6) can be designed as 3 separate switches used to select one of the seven different frequency steps. These (SPD_L, SPD_M, SPD_H) are in binary code. If P1, P2, P3 and P4 terminals were programmed (via **I/O 01 – I/O 06**) to be SPD_L, SPD_M, SPD_H and JOG respectively, then when P1 is open, P2 is open, and P3 is closed, SPD_L is binary zero, and SPD_H is a binary one. The highest bit is 'SPD_H', and the lowest bit is 'SPD_L'. Therefore, the above terminal inputs will represent '001' in binary, which is 'frequency step #4'. When the drive receives this '001', it searches for the preprogrammed step frequency reference #1 (**I/O 13**). However, these step frequency references must be programmed in to **I/O 13 – I/O 19**. Refer to Application Notes, Section 9.1 – Pre-set Speed Operation.

Multi-step Speed selection table

	Speed 0	Speed 1	Speed 2	Speed 3	Speed 4	Speed 5	Speed 6	Speed 7
SPD_L	0	1	0	1	0	1	0	1
SPD_M	0	0	1	1	0	0	1	1
SPD_H	0	0	0	0	1	1	1	1

0: inactive (off), 1: active (on)

Example:

P1 is configured as SPD_L.

P2 is configured as SPD_M.

P3 is configured as SPD_H.

P4 is configured as JOG.

Speed 0 is set in DRV 00 through keypad or analog speed pot.

Speed 1 – 7 are set in **I/O 13 – 19**.

Jog frequency is set in **I/O 12** and the drive direction can be determined by the FX, RX terminals.

Pre-set step speeds using P1, P2, P3, P4, FX, RX are shown as follows.

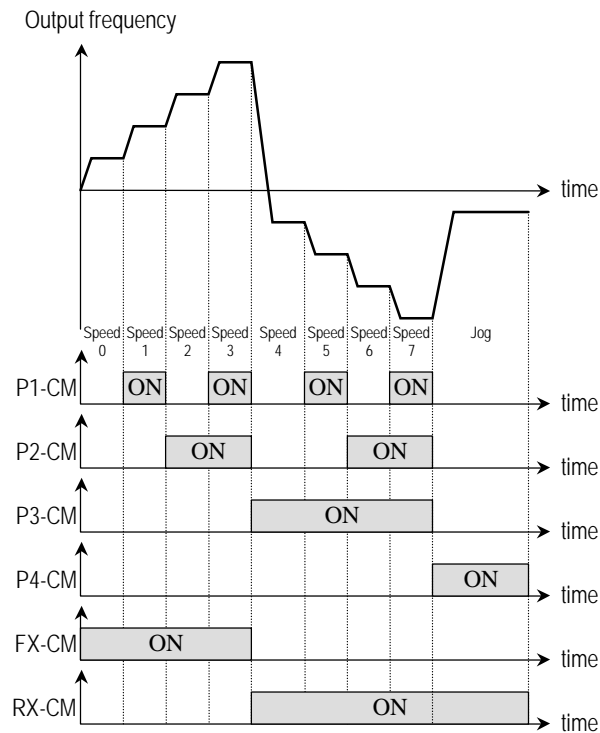

[Multi-step speed drive]

6.11.2 JOG

One of the multi-function input terminal programmed to become a Jog switch by setting an input terminal to 'JOG'. This can be done by choosing one of P1 – P6 (**I/O 01 – I/O 06**) to 'JOG'. For information on the Jog function, please refer to Section 6.11.2.

6.11.3 ACCT_L, ACCT_M, ACCT_H

The AActionMaster Series H can be programmed to have up to 7 different Accel/Decel times by configuring three of the six terminals to ACCT_L, ACCT_M, ACCT_H (Lowest bit, Middle, Highest bit). The Accel/Decel times are set in **I/O 20 – I/O 33**.

Multi-Accel / Decel time selection table

	Time 0	Time 1	Time 2	Time 3	Time 4	Time 5	Time 6	Time 7
ACCT_L	0	1	0	1	0	1	0	1
ACCT_M	0	0	1	1	0	0	1	1
ACCT_H	0	0	0	0	1	1	1	1

0: inactive (off), 1: active (on)

The Time 0 Accel/Decel time is configured by DRV 01-02 and selected when no Accel/Decel input terminals are active. The Time 1-7 Accel/Decel times are set in I/O 20-33.

Example:

If P4 is configured as ACC_L, P5 is configured as ACCT_M, and P6 is configured as ACCT_H, then the transition time from one step to another can be shown below:

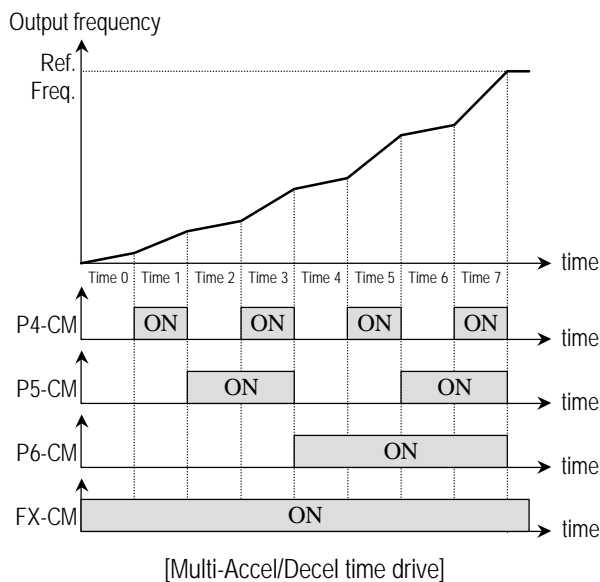

6.11.4 UP, DOWN

By configuring one of multi-function input terminals to 'UP' or 'DOWN', the drive can increase or decrease its output frequency as long as this terminal is closed to common. If P1, P2 are configured as 'UP' and 'DOWN' respectively.

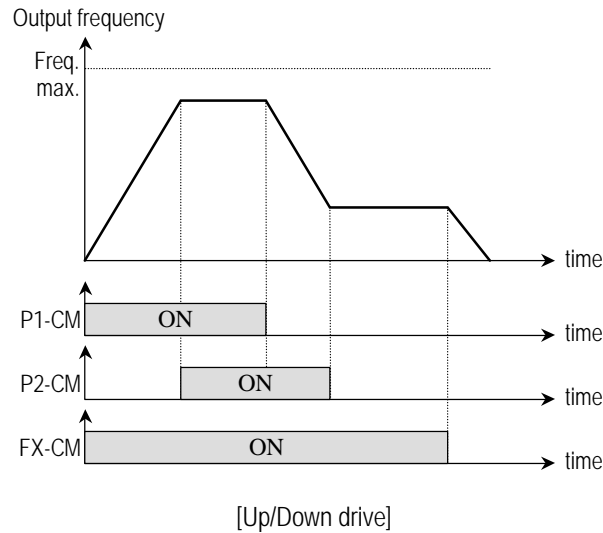

6.11.5 HOLD

This function is for '3-WIRE' control operation. This function is mainly used with a momentary push button to hold the current frequency output during acceleration or deceleration. If P2 is configured as 'HOLD', refer to Application Note, Section 9.2 – 3-Wire Operation.

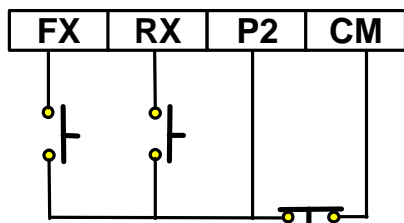

[Wiring for 'HOLD' drive]

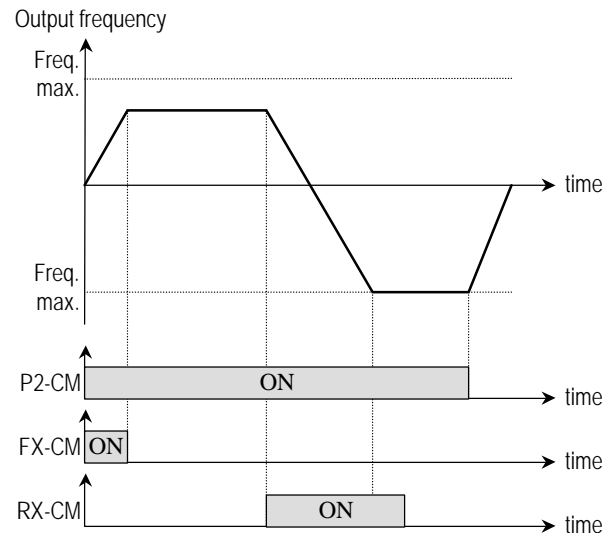

6.11.6 OPT_MAN : Reserved for future use.

6.11.7 COMM_CON

Used for the bypass (commercial line exchange) command. See Chapter 9 – Application Notes, Section 9.3 – Exchange Inverter to Commercial Line Operation.

6.11.8 EXT_DCBR

The ‘DC Injection Brake’ can be applied when a multi-function terminal configured as ‘EXT_DCBR’ is closed to common. This DC injection can be applied at zero drive output frequency. When used with the ‘RUN’ command for starting, the drive can immediately engage its motor to start rotating without being pulled in the reverse direction. The total amount of DC injection voltage can be programmed via **FUN 36**. The value of FUN 36 is the maximum voltage the drive will put out the motor during the DC injection command.

Example:

If a multi-function input terminal ‘P4’ is configured as ‘EXT_DCBR’, then the ‘DC Injection Brake’ can be applied by closing terminal ‘P4’ while the motor sits at zero frequency. Let’s say the motor is connected to a load with some weight, and is holding its position by means of a mechanical break. In order to prevent the ‘Sliding Back’ of the motor at the time of the brake release, the drive can apply DC injection braking voltage to hold the load for a short period of time. While the DC injection is active, one can initiate the ‘Forward Run’ command at the same time of the brake release. This will result in the motor rotating with no or minimal ‘Sliding Back’ effect.

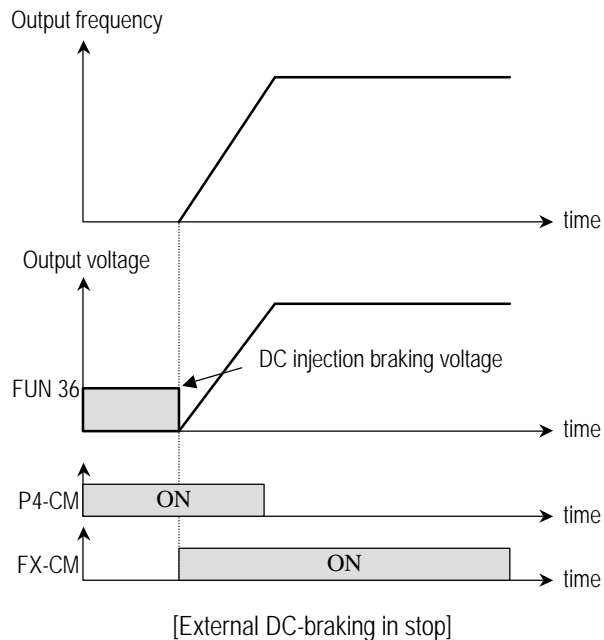

6.11.9 EXT_TRIP

The ACtionMaster Series H drive can be configured to trip and stop via an external terminal by programming one of the multi-function input terminals. For example, if the 'P4' terminal is configured to be 'EXT_TRIP', the drive will decelerate as configured in **FUN 15 [Sop Pattern selection]** when 'P4' is closed. Once this 'EXT_TRIP' is triggered, the drive must be RESET and the RUN command must be re-initiated to restart the drive. This switch is 'Normally Closed' during normal operation and 'Opened' during a fault condition.

6.12 Multi-Function Outputs

The AActionMaster Series H drive is equipped with 3 Open Collector Outputs (OC1, OC2 and OC3) and 2 Auxiliary Relay Outputs (AUX1, AUX2) terminals. They all can be configured as drive status output terminals via **I/O 07 – I/O 11** in the I/O Group.

I/O 07 – I/O 11: Multi-function Output Terminals

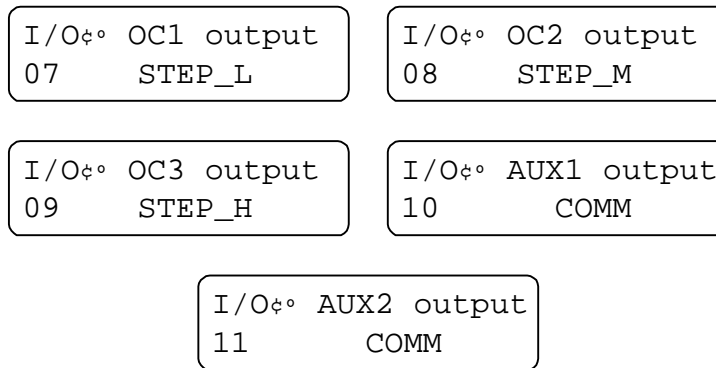

Multi-function Output Terminal Selection Table

I/O 07 - I/O 11 Choices	Definition
FST_LO	Turned on below I/O 38
FST_HI	Turned on above I/O 38
FDT_HI	Turned on above I/O 38 , Turned off below the value of I/O 38 minus I/O 40
FDT_PULSE	Pulsed On above I/O 39, Pulsed On below the value of I/O 39 minus I/O 40
FDT_BAND	Turned on between I/O 39 minus I/O 40*1/2 and I/O 39 plus I/O 40*1/2
OL	Overload Signal
STALL	Stall Signal
LV	Low Voltage Signal
RUN	On during running
COMM	Commercial Line Exchange
STEP_L STEP_M STRP_H	Binary format signal during the multi-step speed drive.

Below is an example of terminal configuration.

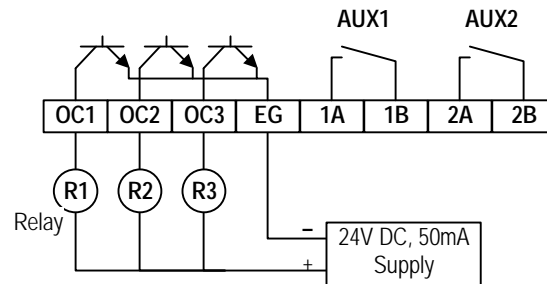

6.12.1 FST_LO

During acceleration, deceleration and constant speed conditions, the ACtionMaster Series H can generate an output signal via the multi-function output terminals when its output frequency is below the value in **I/O 38**. (If an operator wants to have a method to see if the drive is generating output frequency less than the 'Frequency Steady Level' value for his particular application, this can be done by selecting the 'FST_LO' and setting the frequency level in **I/O 38**.)

I/O 36: Frequency Steady Level

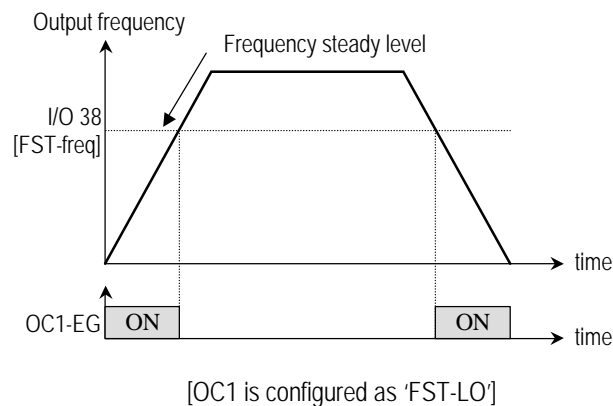

6.12.2 FST_HI

This function is used as 'FST_HI', and the output signal is generated when the drive output frequency is higher than the frequency steady level value set in **I/O 38**.

I/O 38: Frequency Steady Level

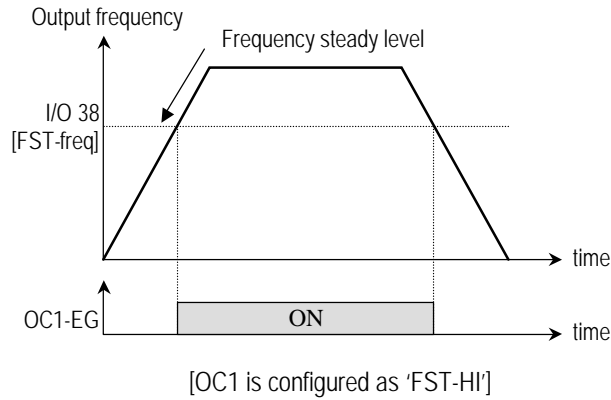

6.12.3 FDT_HI

If the operator needs to know whether the drive is operating above a certain frequency level, the 'FDT_HI' can be selected to use one of the multi-function output terminals to generate a signal when the drive output speed is above the set 'Frequency Detection Level'. A 'Frequency Detection Bandwidth' can also be set for a steadier output signal.

I/O 39: Frequency Detection Level

I/O 40: Frequency Detection Bandwidth

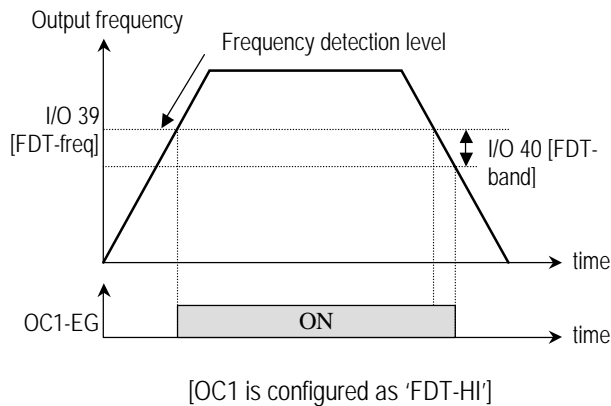

6.12.4 FDT_PULSE

This function is used basically the same way as 'FDT_HI'. Instead of generating a continuous signal until the frequency falls below the set point in **I/O 39** however, it generates a 100ms pulse as the output frequency reaches the value of **I/O 39** during acceleration and deceleration.

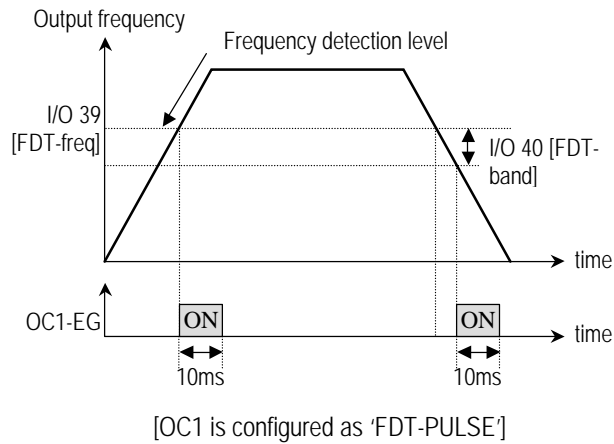

6.12.5 FDT_BAND

If this function is selected, the drive no longer looks for the detection level but only the 'Frequency Bandwidth'. For example, if the output frequency of the drive falls within its programmed bandwidth (**I/O 40**), then the designed multi-function output terminal will generate a signal. This signal will be generated regardless of whether the output frequency of the drive has reached its reference frequency.

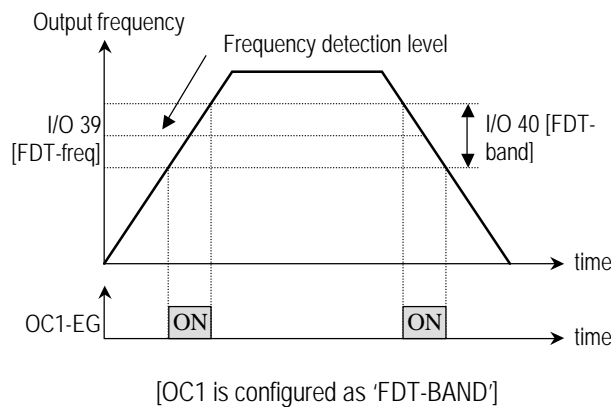

6.12.6 O.L. (Overload Signal)

When the output current has reached the overload warning level set in **FUN 47** for the overload duration time set in **FUN 48**, the drive will generate a signal through one of the ‘O.L.’ designed multi-function terminals. This overload signal will disappear once the current output level falls below the value of **FUN 47** and is held for more than half of the time set in **FUN 48**.

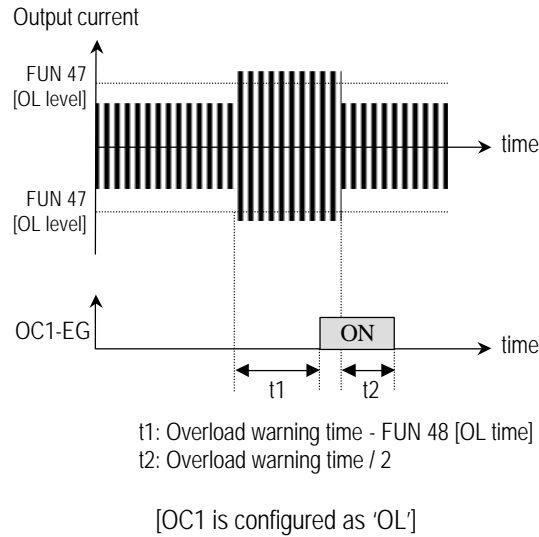

6.12.7 STALL

When the drive stalls, the multi-function output terminal designated to ‘STALL’ will generate a signal. This is true throughout the operation during acceleration, deceleration and steady state conditions.

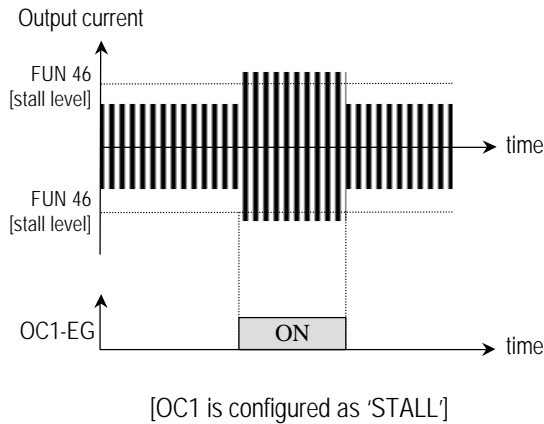

6.12.8 L.L. (Low Voltage)

A multi-function output terminal designed to 'L.V.' will generate a signal when the DC Link voltage falls below the under-voltage level of the drive.

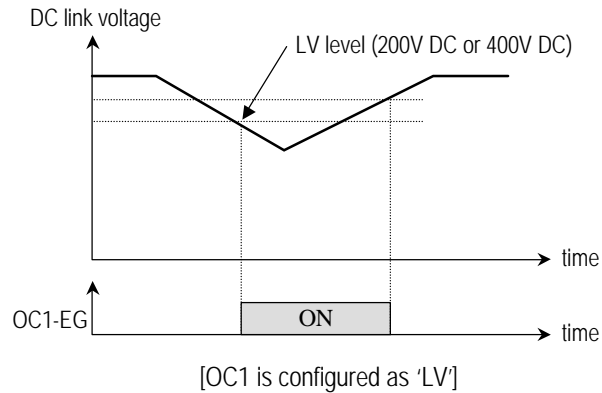

6.12.9 RUN

A multi-function output terminal designed 'RUN' will generate a signal when the drive is operating in 'RUN' mode.

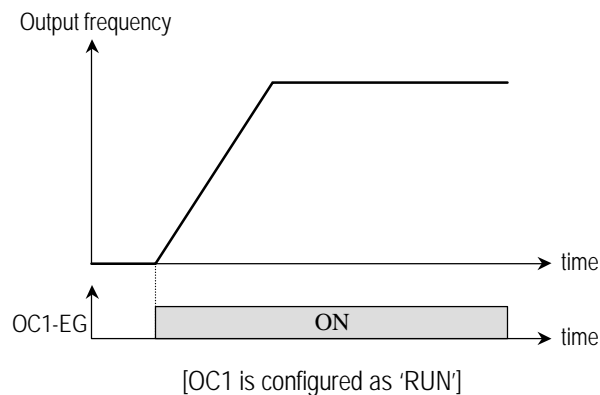

6.12.10 COMM (Direct Power Input)

When a multi-function output terminal configured as 'COMM', the terminal toggles and closes itself whenever the drive is given a command to switch from Bypass mode to Drive mode (in conjunction with Speed Search [SS] Mode). This function is used to trigger an external relay (the Bypass unit). Please refer to the Application Note, Section 9.3 – Exchange Inverter to Commercial Line.

6.12.11 STEP_L, STEP_M, STEP_H

By assigning three multi-function output terminals to these parameters, the operator can monitor the step that the drive is running. The inverter outputs signals in binary format according to the steps selected by multi-function input terminals (I/O 01 – I/O 06) via OC1, OC2, OC3 (configured as STEP_L, STEP_M, STEP_H, respectively).

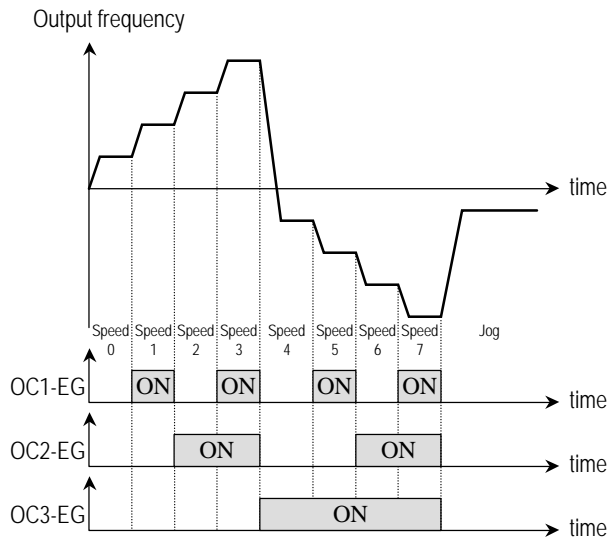

[OC1 is configured as 'STEP_L'
 OC2 is configured as 'STEP_M'
 OC3 is configured as 'STEP_H']

6.13 Drive Operation Monitor

The ActionMaster Series H drive operational status can be monitored via the drive keypad and analog output terminals.

6.13.1 Output Current/Voltage (LM)

I/O 34: Analog Meter Selection (Voltage or Current)

I/O 35: Analog Meter Adjustment

I/O ϕ Analog meter 34 Voltage	I/O ϕ Analog adj. 35 100 %
---------------------------------------	------------------------------------

The AActionMaster Series H drive has an 'LM' terminal which can be programmed to generate either drive 'Voltage' or 'Current' output measurements as a 0-10VDC analog signal. The measurement selection can be programmed in **I/O 34**. When a different ratio between the 'LM' output and the actual drive 'Voltage/Current' measurement is required, the value of **I/O 35** can be set to meet the ratio requirement. Also, refer to 'DI/DA' in this chapter.

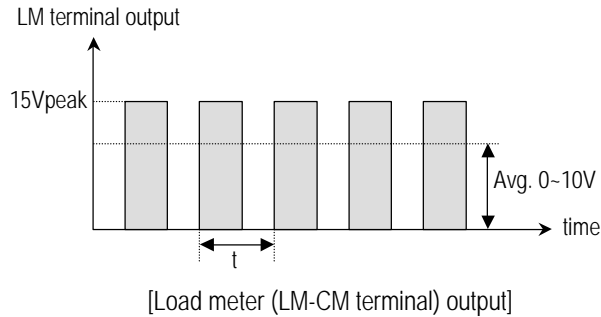

Load meter frequency ($1/t$) = 1.8kHz (fixed)

Duty (%) = (output voltage/maximum output voltage)*2/3 or
(output current/trip current)*2/3

Load meter voltage = (output voltage/maximum output voltage)*10V or
(output current/trip current)*10V

6.13.2 Output Frequency (FM)

I/O 36: Frequency Meter Adjustment (15V Pulse)

I/O#	FM adj.
36	100 %

The drive output frequency can be monitored via the 'FM' analog terminal of the AActionMaster Series H. the 'FM' terminal will generate a '0-10VDC' signal proportional to the drive output frequency. If the ratio between the actual drive frequency output and the analog signal needs to be adjusted, the value in I/O 36 must be set to an acceptable number. The 'FM' terminal gives the drive output frequency in the form of a PWM signal. Please refer to page 90 in this chapter.

6.13.3 Output Frequency (IO)

I/O 37: IO Meter Adjustment (4~20mA)

I/O DAC adj.
37 100 %

The drive output frequency can be monitored via the 'IO' analog terminal of the ACTIONMaster Series H. The 'IO' terminal will generate a '4~20mA' signal proportional to the drive output frequency. If the ratio between the actual drive frequency output and the analog signal needs to be adjusted, the value in **I/O 37** must be set to an acceptable number. Please refer to page 90 in this chapter.

6.13.4 Fault History

The ACTIONMaster Series H drive keeps detailed fault information in two fault history parameters. Each fault history parameter contains the previous fault status: trip type, drive output current, and the frequency output at the time of the trip. These conditions can be viewed by using Up and Down arrow keys on the keypad.

I/O Last fault 1 46 OV Trip	I/O Last fault 2 47 OC Trip
I/O Last fault 1 46 35.60 Hz	I/O Last fault 2 47 60.00 Hz
I/O Last fault 1 46 16.5 A	I/O Last fault 2 47 50.6 A

6.13.5 Terminal Status

Both the input and output terminal's status can be monitored via **I/O 43** and **I/O 44**. This feature is an especially useful tool for drive troubleshooting. The status of each terminal is displayed in binary form. If a terminal is activated, the display will show 'High (1)'. Otherwise it will show 'Low (0)'.

I/O ϕ Ter. input
43 1000000001

I/O ϕ Ter. output
44 10001

Input Terminal Status

P6	P5	P4	P3	P2	P1	X	X	RX	FX
1	0	0	0	0	0	0	0	0	1

Output Terminal Status

AUX2	AUX1	OC3	OC2	OC1
1	0	0	0	1

6.13.6 Software Version**I/O 45:** S/W Version

I/O ϕ S/W version
45 1.00H

6.13.7 DI/DA (Digital Input/Analog Output)**I/O 59:** DA Mode

I/O ϕ DA Mode
59 Freq.

This function is to be used when a DI/DA option card is installed in the drive. The card will generate a '4~20mA' analog signal for either the drive output voltage or current depending on the value programmed in **I/O 59**.

6.14 Option Card**I/O 48:** Option Card 1 Selection**I/O 49:** Option Card 2 Selection

I/O ϕ Option 1
48 None

I/O ϕ Option 2
49 None

■ RS485

Communication between the drive and a computer can be achieved by using the AActionMaster Series H drive software protocol. Refer to RS485 option manual.

■ PG (Pulse Generator)

Accurate speed control of the motor can be achieved by using encoder feedback. Refer to the PG option manual.

■ DI/DA

The drive can receive its frequency reference from a '12 bit' digital input source via the DI/DA option card. Also, the drive can generate a '4~20mA' analog output signal referenced to its voltage and current readings. Refer to DI/DA option manual.

■ CAN

This option makes it possible for the drives to communicate with each other. Refer to CAN option manual.

■ PLC

This is a PLC interface card, which enables the drive to communicate at high speed (1Mbps). Refer to PLC option manual.

■ DeviceNet

The AActionMaster Series H can be connected to a DeviceNet network using this option card. Refer to DeviceNet option manual.

I/O 50: Drive Address Setting

I/O#	Inv. number
50	1

This function is used with the PLC/RS485/DeviceNet option card to designate a unique address for multi-drive/computer communication.

6.15 P.I. Control

- FUN 62:** PI Control Selection
FUN 63: Proportional Gain
FUN 64: Integral Gain
FUN 65: PI-Feedback Offset
FUN 66: PI-Feedback Scale

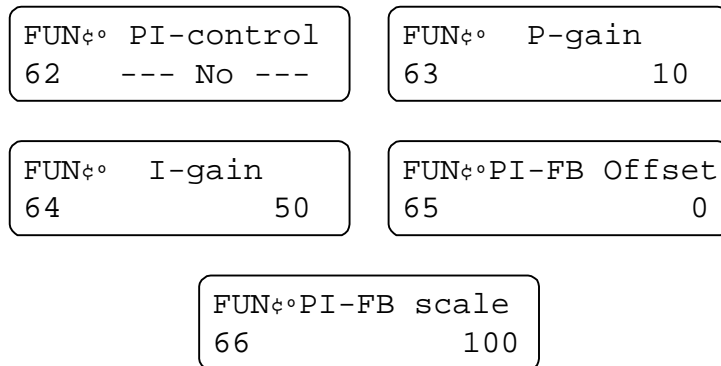

For HVAC or Pump applications, the PI function can be used to adjust the actual output by comparing a feedback with a 'Set-point' given to the drive. This 'Set-point' can be in form of Speed, Temperature, Pressure, Flow level, etc. Both the 'Set-point' and the feedback signals are provided externally to the drive analog input terminals VI and I respectively. The drive compares the signals in calculating 'total-error' which is reflected in the drive output.

FUN 62 is used to select the 'PI-Control' function. The Proportional Gain in **FUN 63** is used to set the target window (band) in which the drive will try to maintain its output speed. The Integral Gain in **FUN 64** is set to adjust the drive output response time referenced to the Feedback signal. However, if this value is too large or small, then the motor output will overshoot or under-damp.

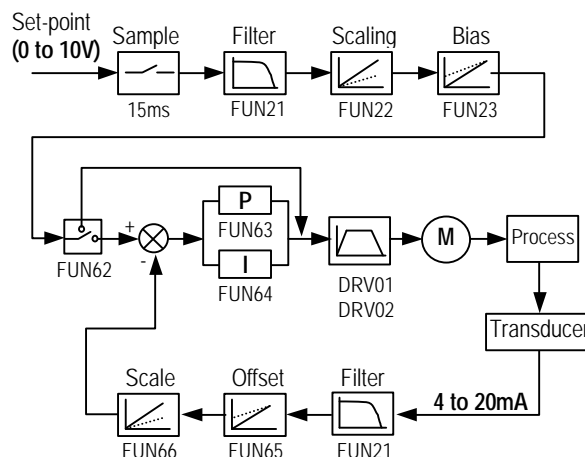

6.16 Resetting Fault

This ACtionMaster Series H drive fault can be reset either from the keypad or from the external fault reset terminal 'RST'. For the keypad reset, please refer to Keypad Operation.

6.17 Sequential Reference

The ACtionMaster Series H drive can receive its sequence command (RUN, STOP, JOG, FWD, REV) either via keypad or external terminals.

6.17.1 Via Keypad

On the keypad of the ACtionMaster Series H, separate RUN, STOP, FWD, REV buttons exist for easy access to the drive sequence. Refer to Keypad Operation.

6.17.2 Via External Terminal

Each of the sequence commands can be initiated via external terminals. They are:

- FX:** Forward Direction Command Terminal
- RX:** Reverse Direction Command Terminal
- BX:** Inverter Disable
- RST:** Fault Reset Terminal
- P1-P6:** Jog programmable terminal
- CM:** Common Terminal for [FX], [RX], [BX], [RST], [P1-P6]

Also, refer to External Terminal Operation.

6.18 V/F Pattern

FUN 08: Volts per Hertz Pattern Selection

FUN \dagger : V/F pattern
08 Linear

Depending on the application, different Volts/Hertz patterns can be selected. For example, in HVAC application, the 'Squared' pattern can be selected since it is well suited for variable torque application.

■ Linear [Constant Torque Application]

This pattern is best suited for 'Constant Torque' applications like 'Conveyors'. This 'Linear' pattern has a V/F ratio that is constant through the entire frequency range up to the drive's base frequency.

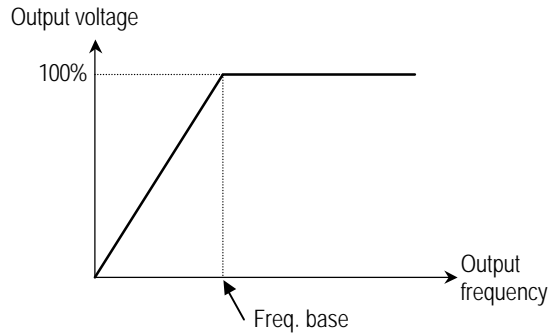

■ Squared [Variable Torque Application]

The V/F ratio in this mode is no longer a constant. Instead, the ratio is squared. This makes 'Squared' mode suitable for variable torque applications such as FAN and PUMP.

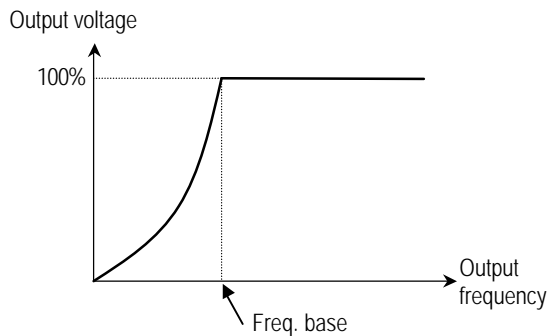

■ User [Custom Pattern]

The 'User' pattern can be used for special purpose applications. There are 2 V/F points that can be programmed between the starting frequency and the base frequency.

FUN 16: User V/F Set Frequency 1f

FUN 17: User V/F Set Voltage 1v

FUN 18: User V/F Set Frequency 2f

FUN 19: User V/F Set Voltage 2v

FUN 16 – FUN 19 are valid only when 'User' is selected in **FUN 08**.

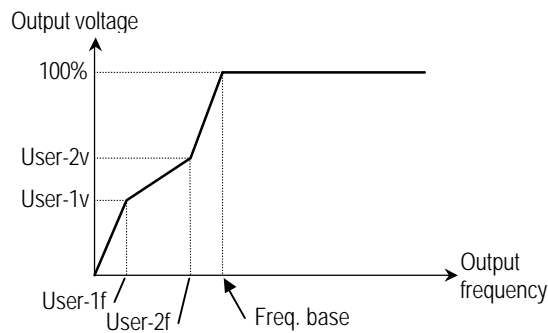

■ **Auto [Auto Boost]**

The 'Auto boost' can be used in high starting torque applications such as cranes and hoists. This pattern will automatically boost the output torque by sensing its load current demand. As a result, the drive will have a higher torque characteristic at the low output speed range than in the Linear pattern mode. The amount of torque boost is determined automatically by the drive calculations. This 'Auto' pattern should not be used in multi-motor applications.

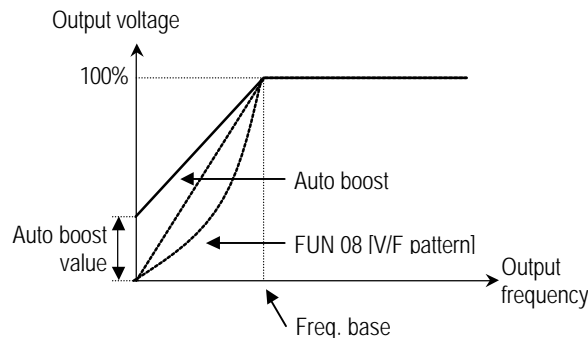

CHAPTER 7 - TROUBLESHOOTING

7.1 How to Check Power Components

Before checking the power components, be sure to disconnect AC Input supply and wait until the Main Electrolytic Capacitors (DCP-DCN) discharge.

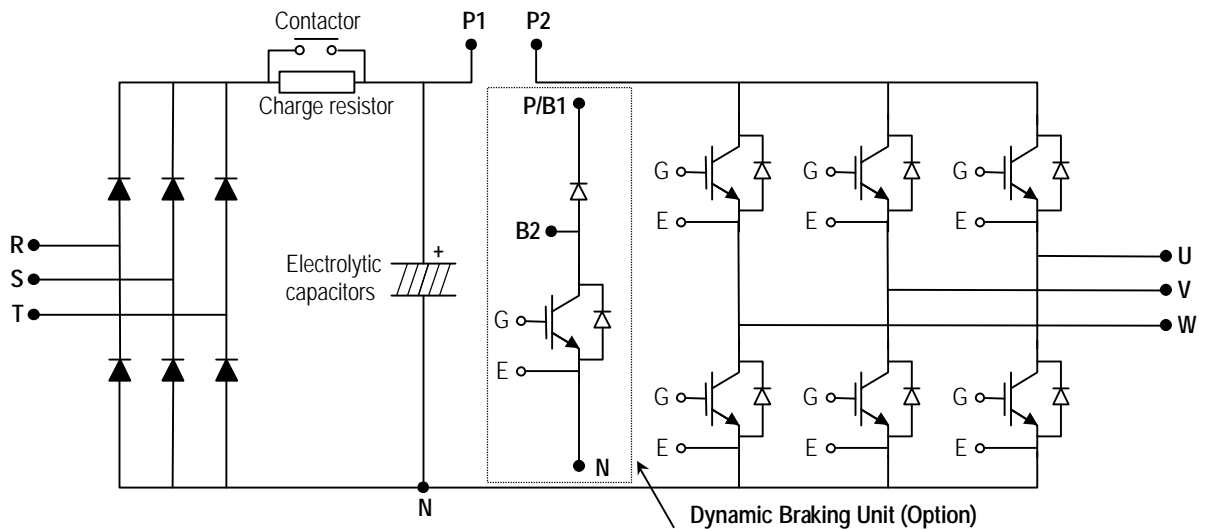

■ Diode Module Check

Check point	Resistance to be Good
R, S, T – P1	50 k ohms or more
R, S, T – N	50 k ohms or more

■ Charge Resistor Check

Check point	Resistance to be Good
Contactur terminals	Resistance depending on models

■ DB (Dynamic Braking) IGBT (Option)

Check point	Resistance to be Good
B2 - N	50 k ohms or more
G - N	A few kilo ohms

■ IGBT Module Check

Check point	Resistance to be Good
B2 - N	50 k ohms or more
G - N	A few kilo ohms

7.2 Fault Trip Description

When a fault trip occurs, the inverter cuts off its output and displays the fault status in DRV 05. The last two faults are saved in I/O 46, 47 with the operation status at the instance of fault trip.

Fault Display	Description	Remedy
<div style="border: 1px solid black; padding: 5px; width: fit-content;"> DRVϕ Fault 05 No Fault </div>	The output current of the inverter has reached the over-current protection level.	<ul style="list-style-type: none"> ■ Extend acceleration time in DRV 01 ■ Reduce the torque boost in FUN 09, 10. ■ Check wiring to motor for possible short-circuits. ■ If problem persists, the load inertia may be too great for the inverter. A larger inverter may be required.
<div style="border: 1px solid black; padding: 5px; width: fit-content;"> DRVϕ Fault 05 GF trip </div>	Inverter output terminal (U, V or W) shorted to ground.	<ul style="list-style-type: none"> ■ Check the wiring from the inverter to motor for ground. ■ Check motor windings for ground fault.
<div style="border: 1px solid black; padding: 5px; width: fit-content;"> DRVϕ Fault 05 OV trip </div>	The DC bus voltage of the inverter is over the over-voltage protection level.	<ul style="list-style-type: none"> ■ Check whether the input voltage is within the limits of the inverter specification. ■ Extend deceleration time in DRV 02 to accommodate the high inertia level. Additional DV unit may be required to dissipate excessive energy. ■ Eccentric loads and regenerative loads may cause over-voltage trips. A larger inverter may be required to accommodate the larger load requirement.
<div style="border: 1px solid black; padding: 5px; width: fit-content;"> DRVϕ Fault 05 OC limit </div>	The output current of the inverter has been exceeded. The value set in FUN 49 over the time set in FUN 50.	<ul style="list-style-type: none"> ■ Check for mechanical failure which may have caused excessive motor current (bearing failure, jam, brake sticking , etc)
<div style="border: 1px solid black; padding: 5px; width: fit-content;"> DRVϕ Fault 05 Fuse Open </div>	The internal fuse is opened. This is caused when an IGBT on the output side of the inverter is damaged. The fuse opens to prevent further damage.	<ul style="list-style-type: none"> ■ Check whether the IGBTs are damaged. ■ Replace the fuse.

Fault Display	Description	Remedy
<div style="border: 1px solid black; padding: 5px; width: fit-content;"> DRVϕ° Fault 05 Over Heat </div>	The heat sink temperature of the inverter is over 85°C. (internal heat sensor)	<ul style="list-style-type: none"> ■ Check whether cooling fan is rotating. ■ Check the air inlet and outlet for obstruction. ■ Check the ambient temperature.
<div style="border: 1px solid black; padding: 5px; width: fit-content;"> DRVϕ° Fault 05 ETH </div>	The motor temperature calculated by the 'Electronic thermal' has been exceeded. The value is set in FUN 52.	<ul style="list-style-type: none"> ■ Check whether the ETH level is set correctly. ■ Check whether the inverter is operating at low frequency with heavy load for a long time.
<div style="border: 1px solid black; padding: 5px; width: fit-content;"> DRVϕ° Fault 05 EXT TRIP </div>	The multi-function input terminal configured as 'EXT_TRIP' is opened.	<ul style="list-style-type: none"> ■ Check the multi-function input terminal.
<div style="border: 1px solid black; padding: 5px; width: fit-content;"> DRVϕ° Fault 05 LV trip </div>	The DC bus voltage of the inverter is under the low voltage protection level.	<ul style="list-style-type: none"> ■ Check the input line voltage. ■ If the input line voltage is within the limit, there may be an error in the dynamic braking circuit. Contact the factory of your local distributor for assistance.
<div style="border: 1px solid black; padding: 5px; width: fit-content;"> DRVϕ° Fault 05 BX </div>	The 'BX' terminal is closed.	<ul style="list-style-type: none"> ■ Check the 'BX' terminal.

If the problem persists, please contact factory or your local distributor for assistance.

!! CAUTION !!

Risk of Electric Shock – More than one disconnect switch may be required to de-energize the equipment before servicing.

■ **Motor Does not RUN**

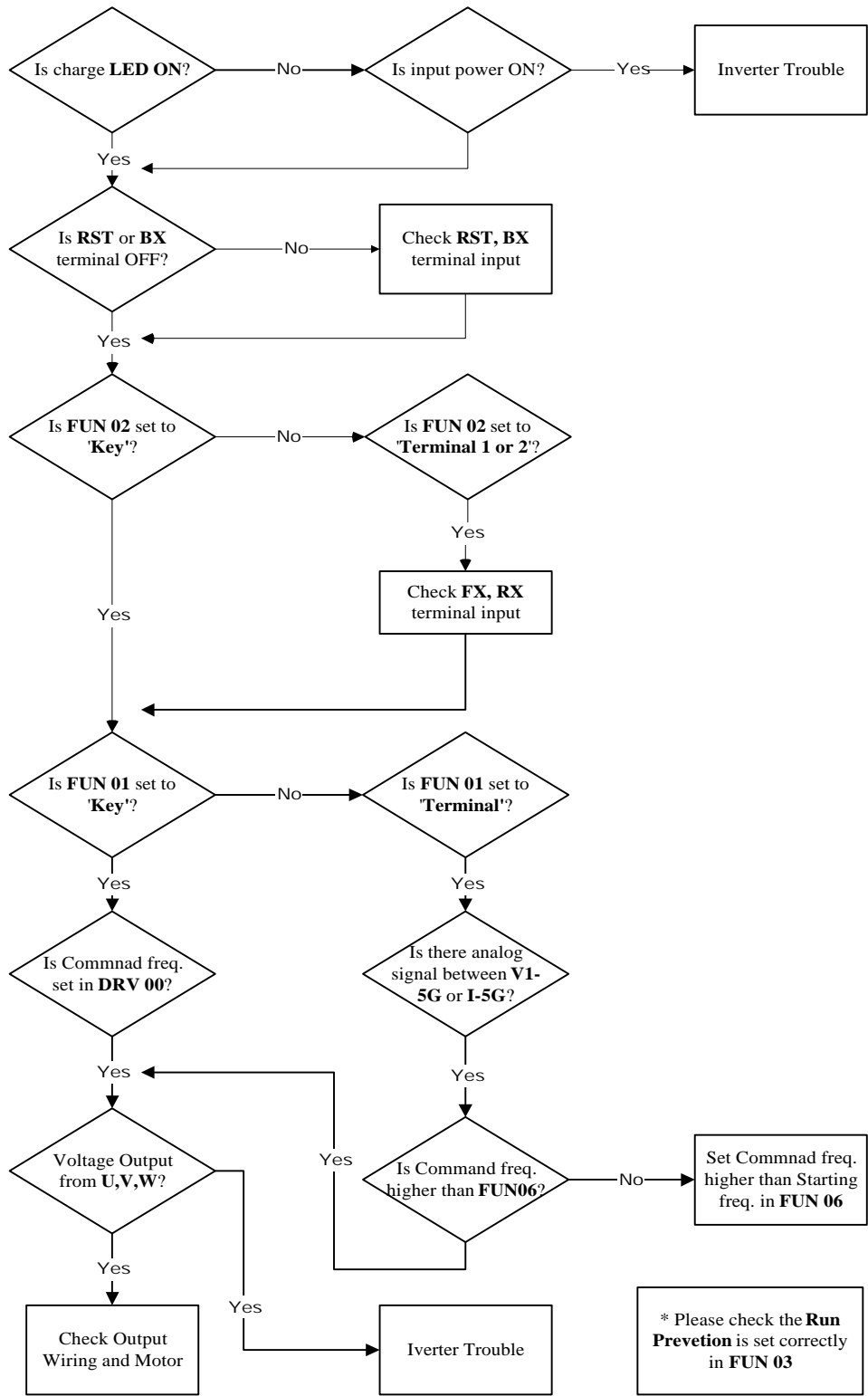

■ Motor Speed is not equal to the Command Frequency

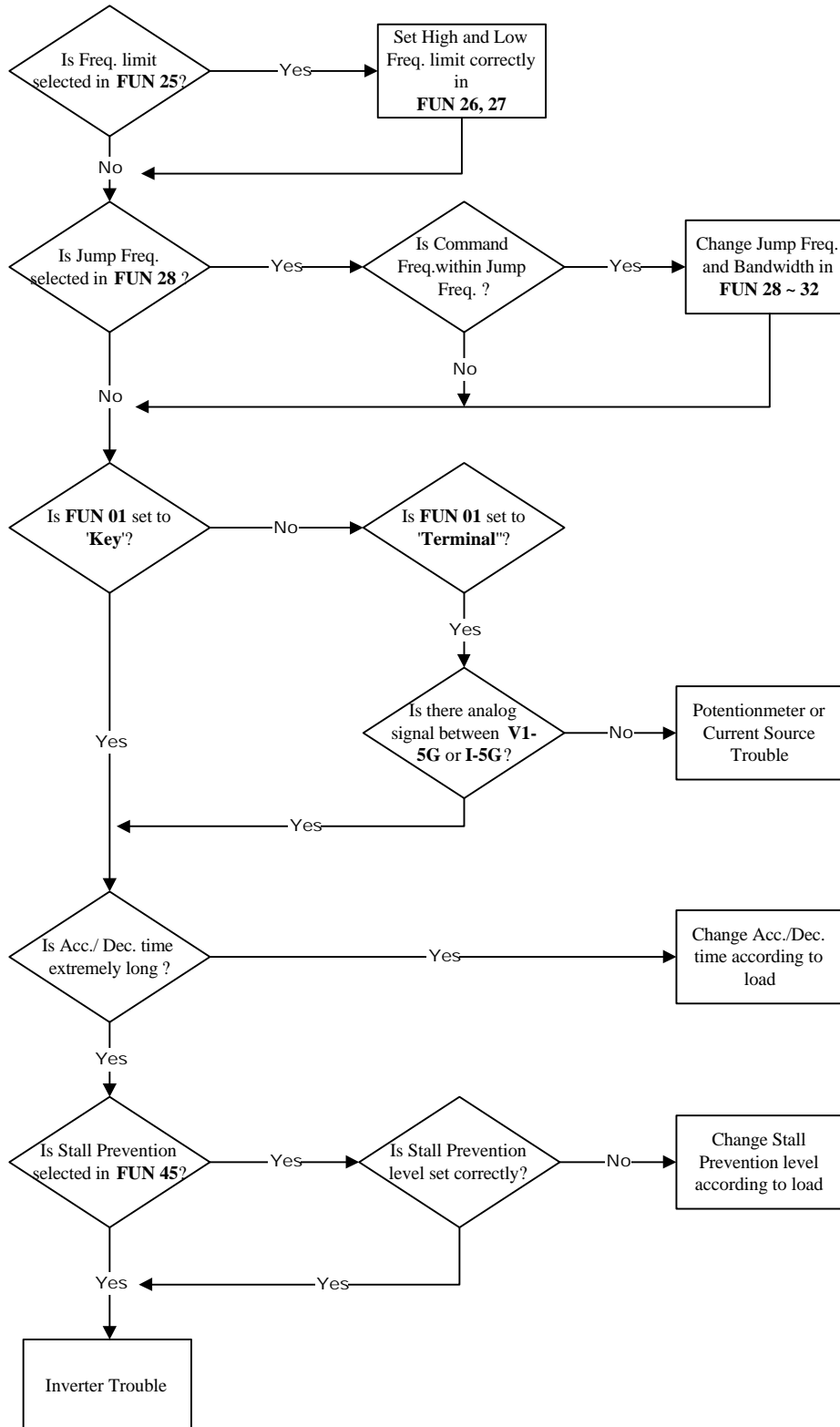

■ Motor does not run Smoothly

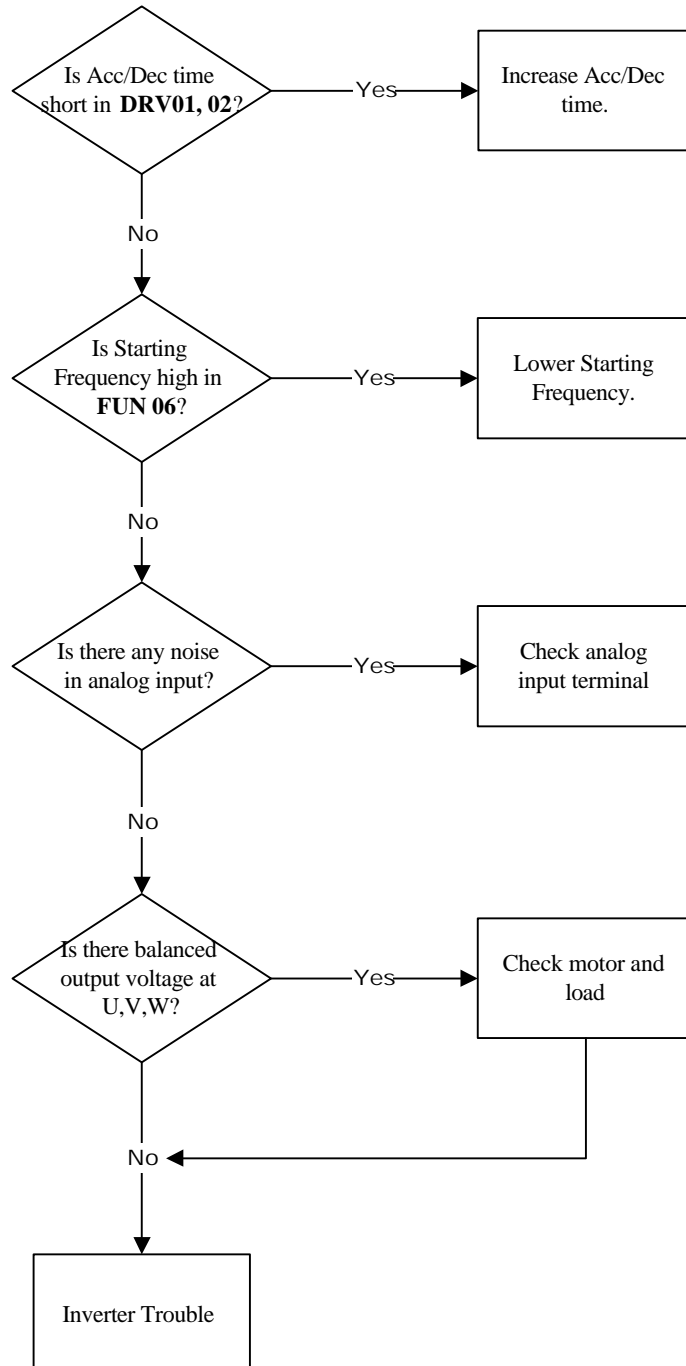

■ **Motor is overheated abnormally**

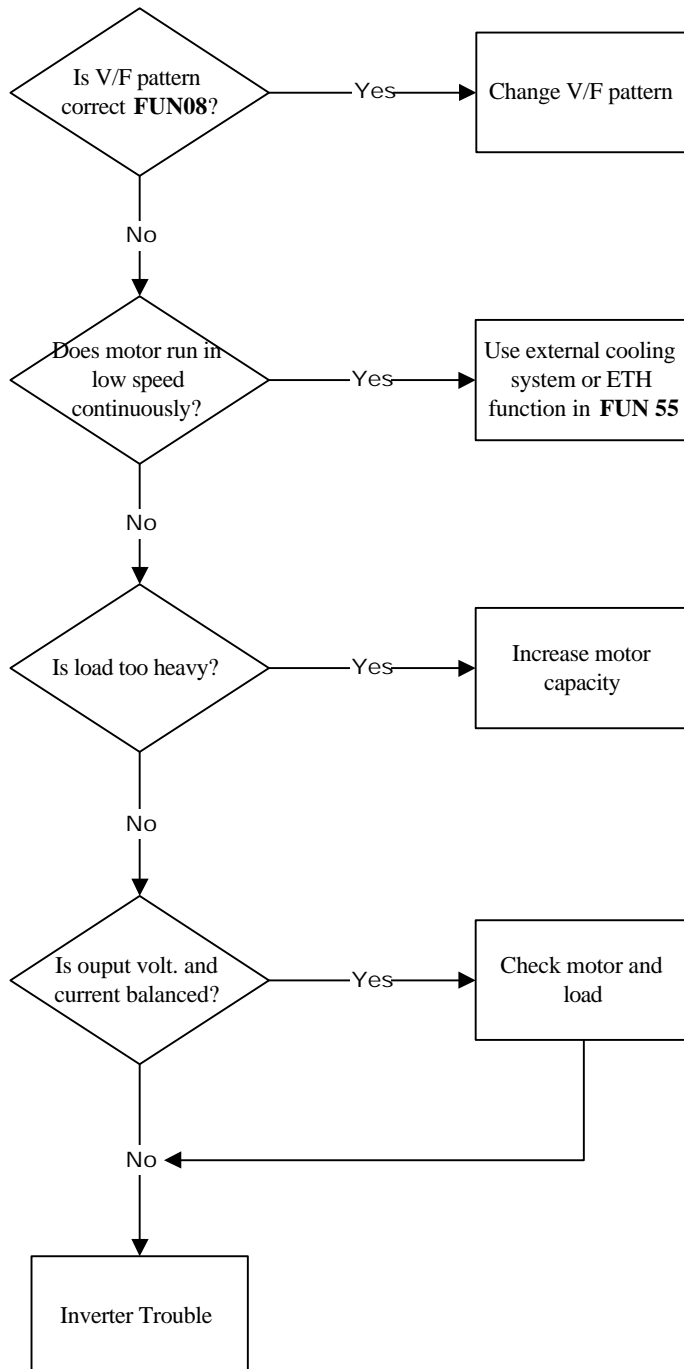

CHAPTER 8 - MAINTENANCE

The Series H series is an industrial electronic product with advanced semiconductor elements, however it can still be affected by temperature, humidity, vibration and eventually aging parts. To avoid this, it is recommended to perform routine inspections.

8.1 Precautions

- Be sure to remove the drive power input while performing maintenance.
- Be sure to perform maintenance only after checking that the bus has discharged. The bus capacitors in the electronic circuit can still be charged even after the power is turned off.
- The correct output voltage can only be measured by using a rectifier voltage meter. Other voltage meters including digital voltage meters are likely to display incorrect values caused by the high frequency PWM output voltage of the drive.

8.2 Routine Inspection

Be sure to check the following before operation.

- The conditions of the installation location.
- The conditions of the drive cooling.
- Abnormal vibration.
- Abnormal heating.

8.3 Periodical Inspection

- Any loose bolt, nut or rust caused by surrounding conditions?
Tighten up or replace.
- Any deposits inside of the drive or cooling fan?
Remove the deposits by using air.
- Any deposit on the drive's PCB (Printed Circuit Boards)?
Remove the deposits by using air.
- Any abnormal contacts in the various connectors of the drive's PCB?
Check the condition of the connector in question.
- Check the rotating condition of the cooling fan, the size and condition of the capacitors and the connections with the magnetic contactor.
Replace it if there is any abnormality.

8.4 Internal Fuse Replacement

When the internal fuse is opened the IGBTs should be checked thoroughly before replacing the fuse. Contact the factory for replacement fuse information.

CHAPTER 9 - APPLICATION NOTES

9.1 Multi-Step Speed (Pre-set Speed) Operation

■ Wiring

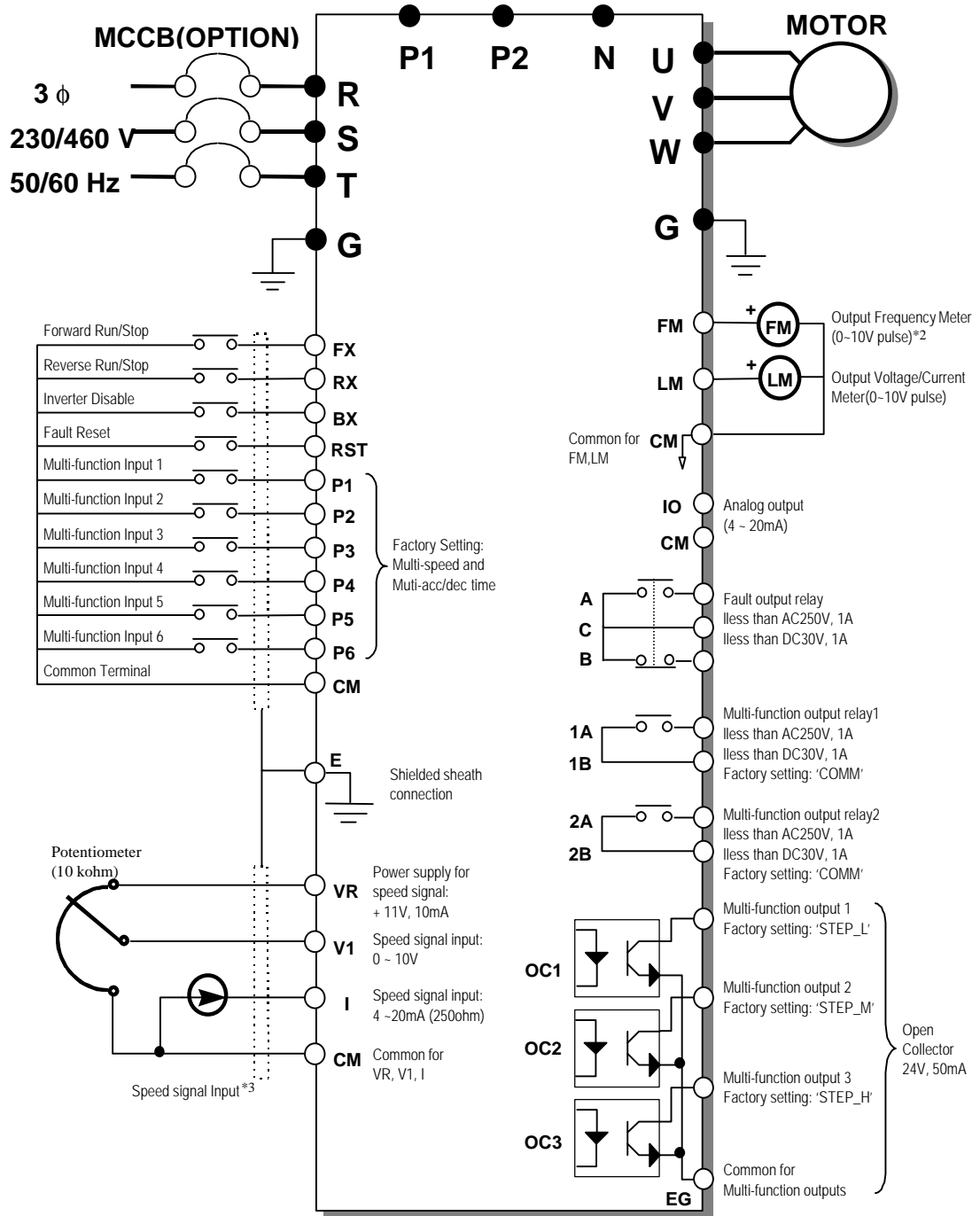

■ **Description of Multi-Step Speed**

Up to 7 different frequency references can be used.

After wiring the inverter as in the figure left:

1. Select the Frequency Reference Source to ‘Key’ or ‘Terminal’ in FUN 01 [Freq. set]. This frequency reference is used for ‘step 0’.
2. Select the Run/Stop Control Source to ‘Terminal-1’ in FUN 02 [Run / Stop set].
3. Configure terminals in I/O 01 – 06 [P1-P6 Input] as table below.
4. If FUN 01 is set to ‘Key’, set the reference frequency of ‘step 0’ in DRV 00. If FUN 01 is set to ‘Terminal’, set the reference with potentiometer.
5. Set the reference frequency of each step in I/O 13 – 19 [Step freq-1 – 7].
6. Set the JOG frequency in I/O 12 [Jog freq.].
7. To run the motor, introduce multi-function input terminals along with the FX, RX or FWD, REV key.

Multi-step Speed selection table

Input Terminal	Configured	Speed 0	Speed 1	Speed 2	Speed 3	Speed 4	Speed 5	Speed 6	Speed 7
P1	SPD_L	0	1	0	1	0	1	0	1
P2	SPD_M	0	0	1	1	0	0	1	1
P3	SPD_H	0	0	0	0	1	1	1	1

0: inactive (off), 1: active (on)

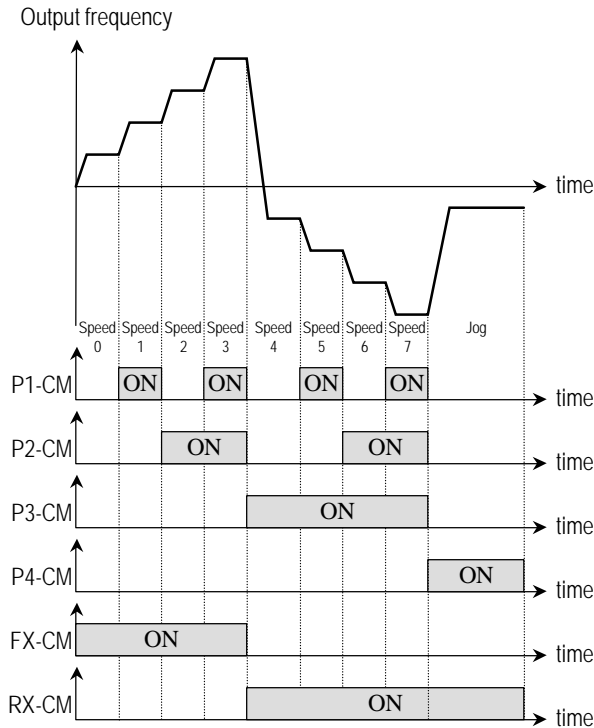

9.2 3-Wire Operation

■ Wiring

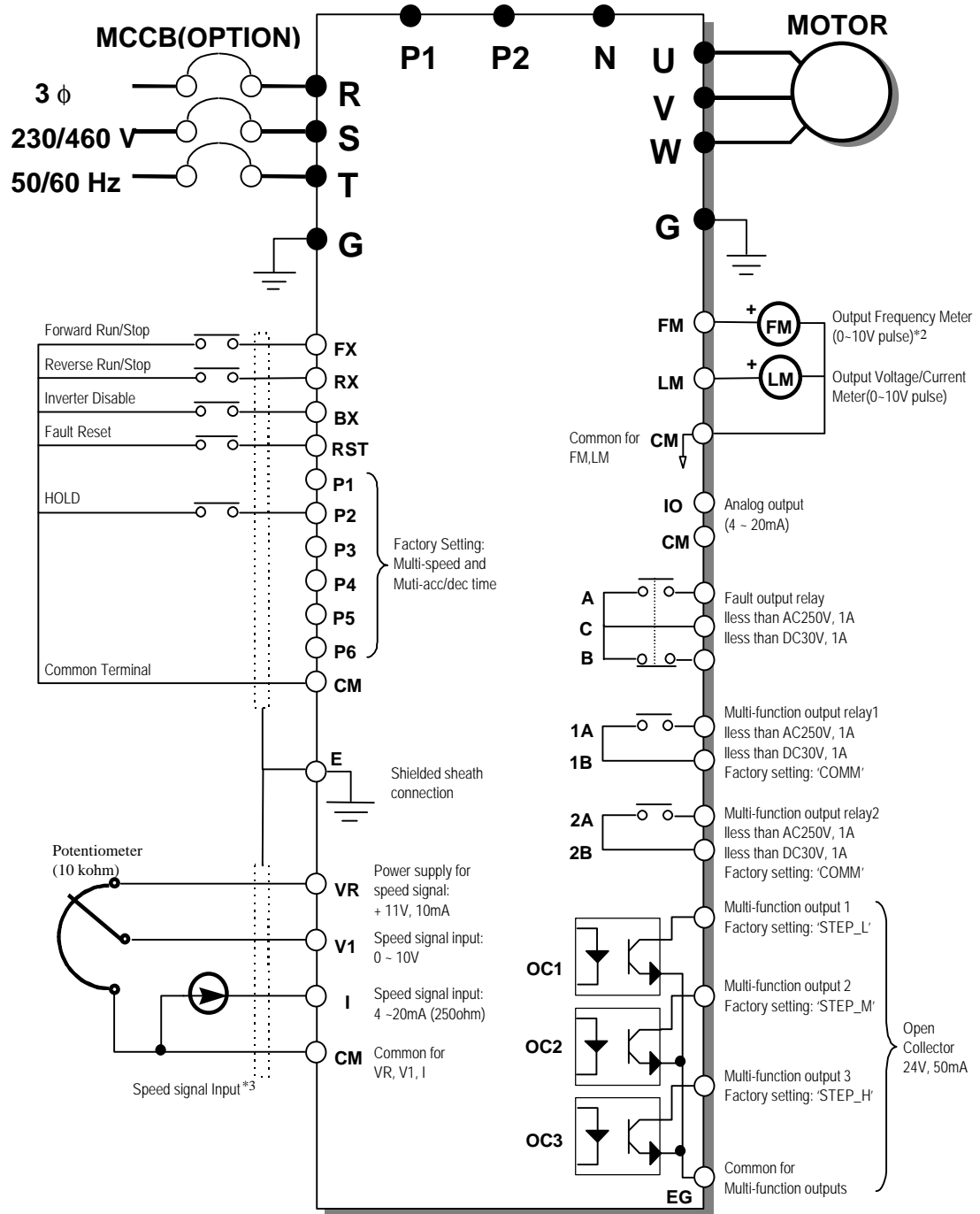

■ **Description of 3-Wire Operation**

The ‘HOLD’ function is used to hold the momentary run command using a push button switch.

After wiring the inverter as in the figure below:

1. Select the Frequency Reference Source to ‘Key’ or ‘Terminal’ in FUN 01 [Freq. set].
2. Select the Run/Stop Control Source to ‘Terminal-1’ in FUN 02 [Run / Stop set].
3. Configure P2 terminal in I/O 02 [P2 Input] as ‘HOLD’.

Once the FX or RX terminal is closed to CM momentarily, the inverter maintains its output. See below figure.

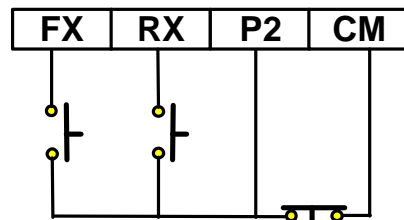

[Wiring for ‘HOLD’ drive]

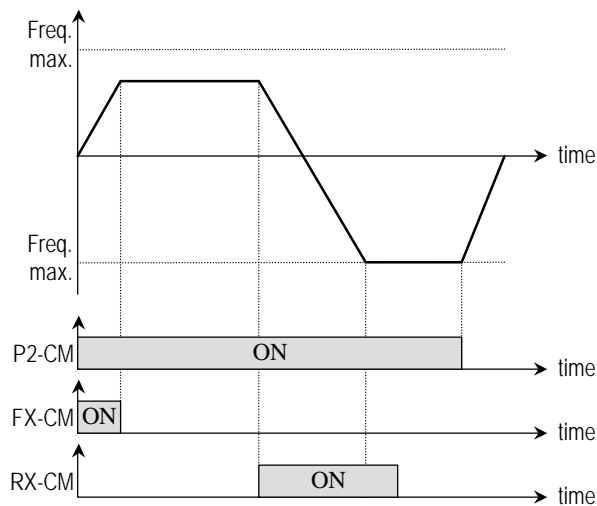

[‘HOLD’ drive]

9.3 Exchange Inverter to Commercial Line Operation

■ Wiring

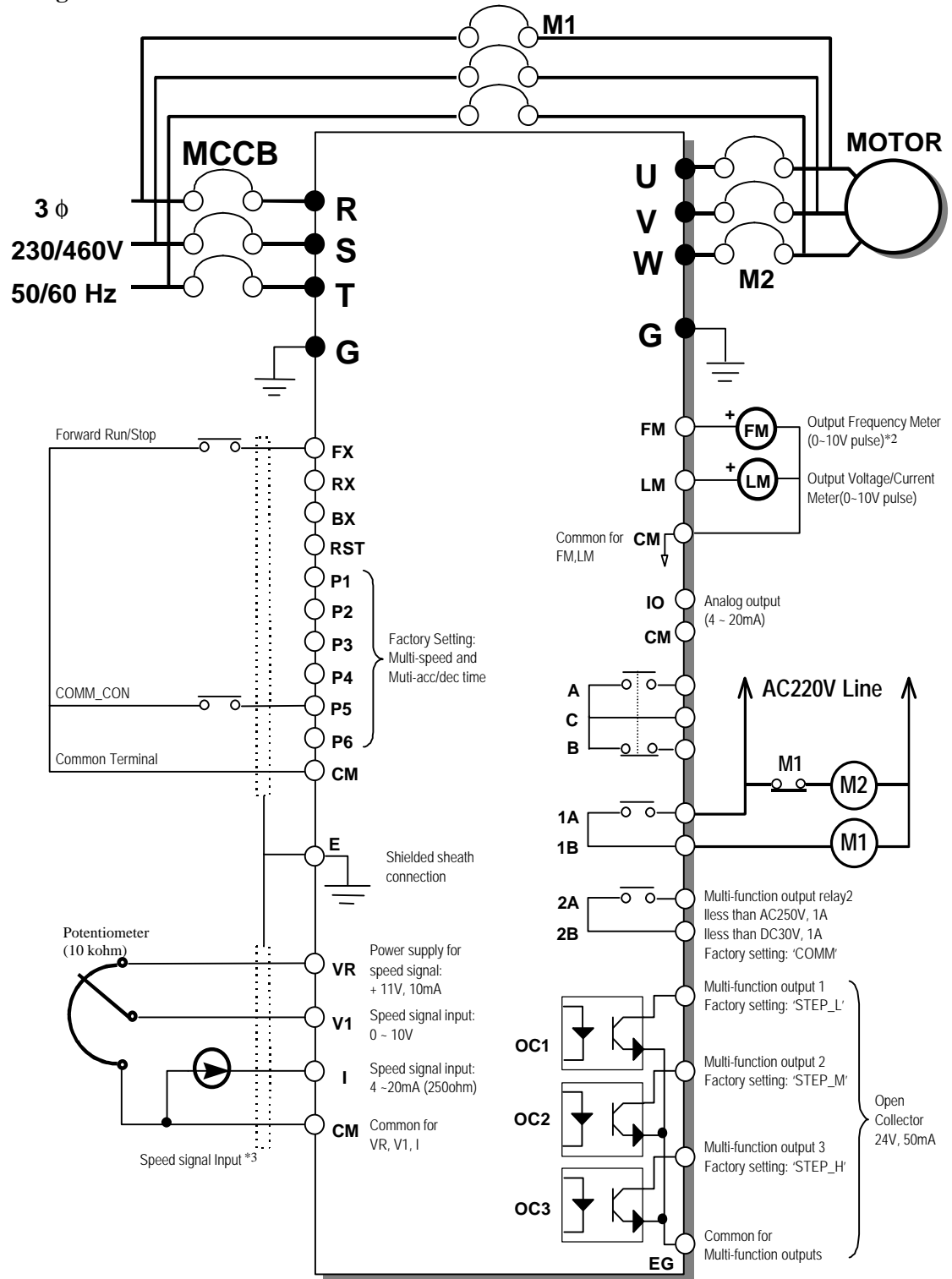

■ Description of Exchange Inverter to Commercial Line Operation

The input of the motor can be exchanged between the Inverter and Commercial Line using the 'COMM_CON' and 'COMM' functions.

After wiring the inverter as in the figure left.

1. Select the Frequency Reference Source to 'Key' or 'Terminal' in FUN 01 [Freq. set].
2. Select the Run/Stop Control Source to 'Terminal-1' in FUN 02 [Run / Stop set].
3. Configure P5 terminal in I/O 05 [P2 Input] as 'COMM_CON'.
4. Configure AUX1 Relay Output as 'COMM' in I/O 10 [AUX1 output].
5. To exchange the motor input from inverter to commercial line, close the P5 terminal to CM.

Note: Motor drive direction must be set up correctly.

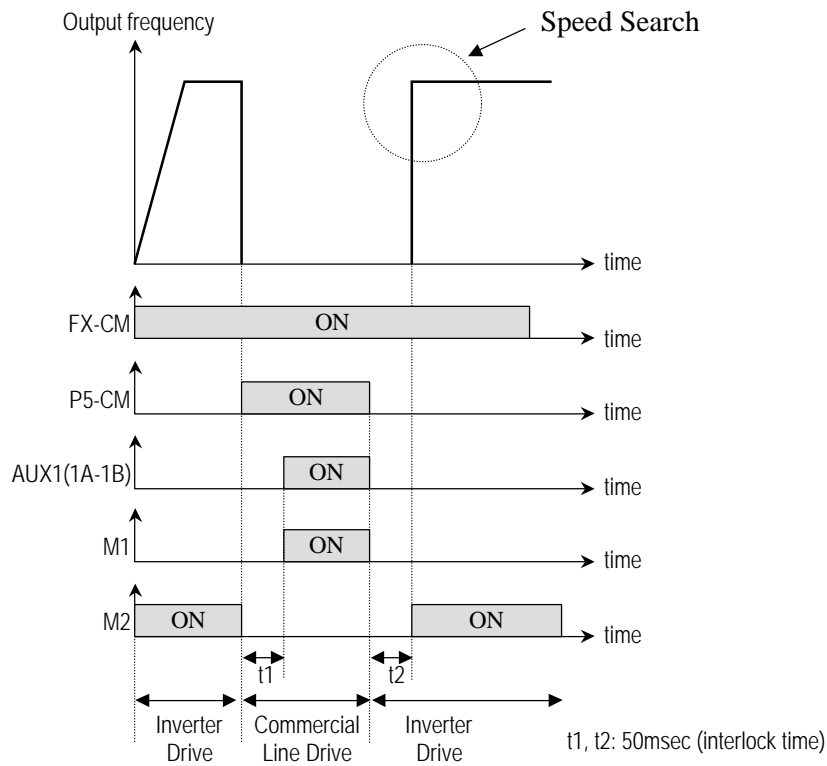

[Commercial Line Exchange]

9.4 Up and Down Operation

■ Wiring

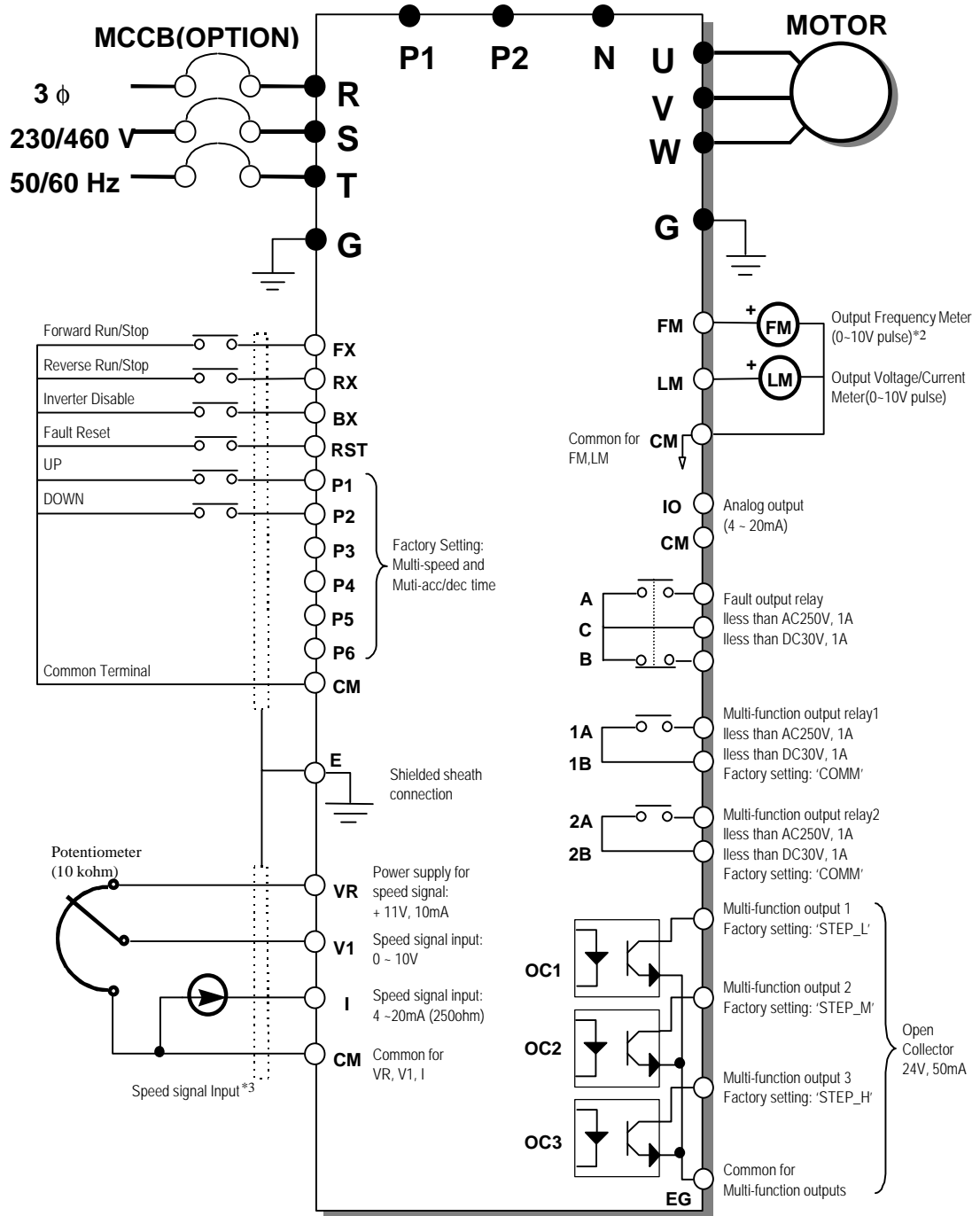

■ Description of Up and Down Operation

The output frequency can be increased and decreased using Up and Down functions.

After wiring the inverter as in the figure on page 133:

1. Select the Frequency Reference Source to 'Key' or 'Terminal' in FUN 01 [Freq. set].
2. Select the Run/Stop Control Source to 'Terminal-1' in FUN 02 [Run / Stop set].
3. Configure P1 terminal in I/O 01 [P1 Input] as 'UP'.
4. Configure P2 terminal in I/O 02 [P2 Input] as 'DOWN'.

See below sequence diagram.

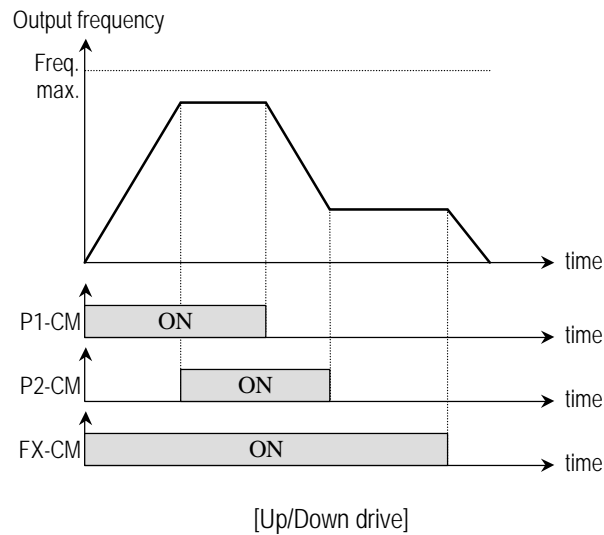

DETAILED DIMENSIONS

■ **Fame #1**
230VAC – 40 Hp (ACM-030H-2), 50 Hp (ACM-037H-2)

Unit: millimeters

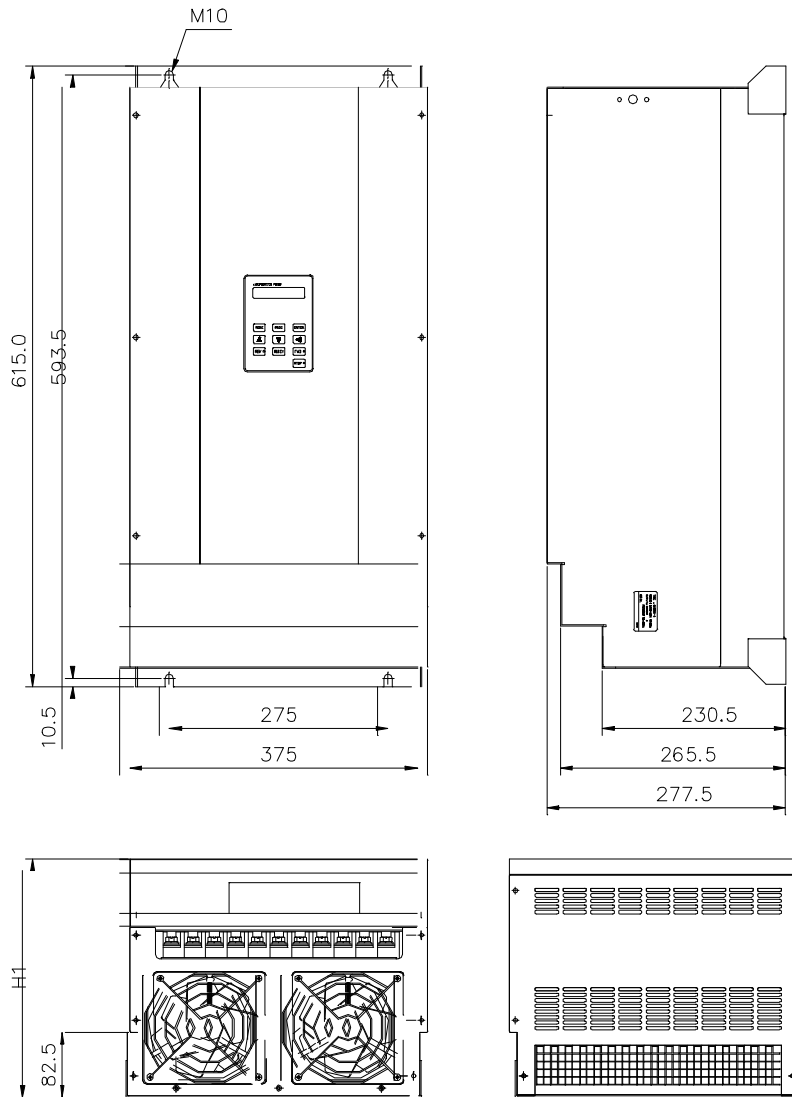

Detailed Dimensions

■ Frame #2 460VAC - 40 Hp (ACM-030H-4)

Unit: millimeters

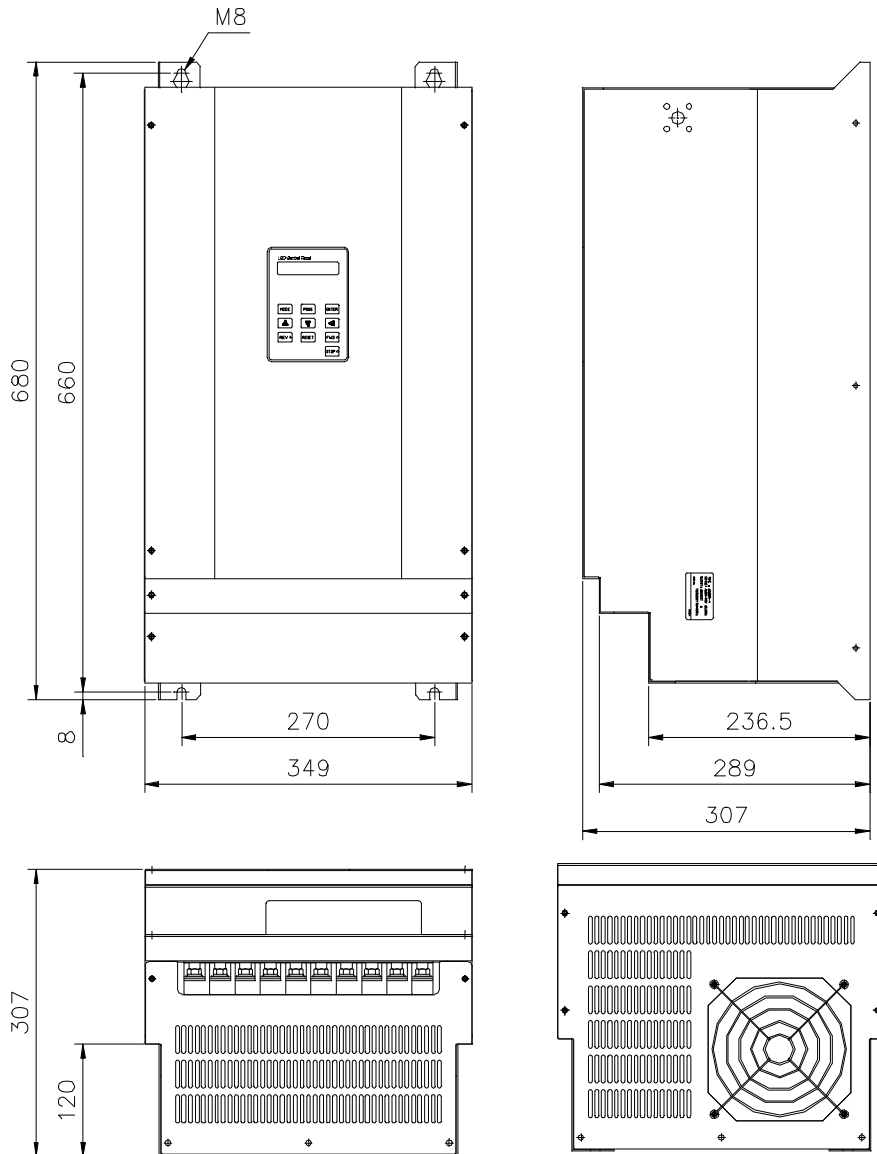

■ **Frame #3**

460VAC - 50 Hp (ACM-037H-4), 60 Hp (ACM-045H-4),

75 Hp (ACM-055H-4)

Unit: millimeters

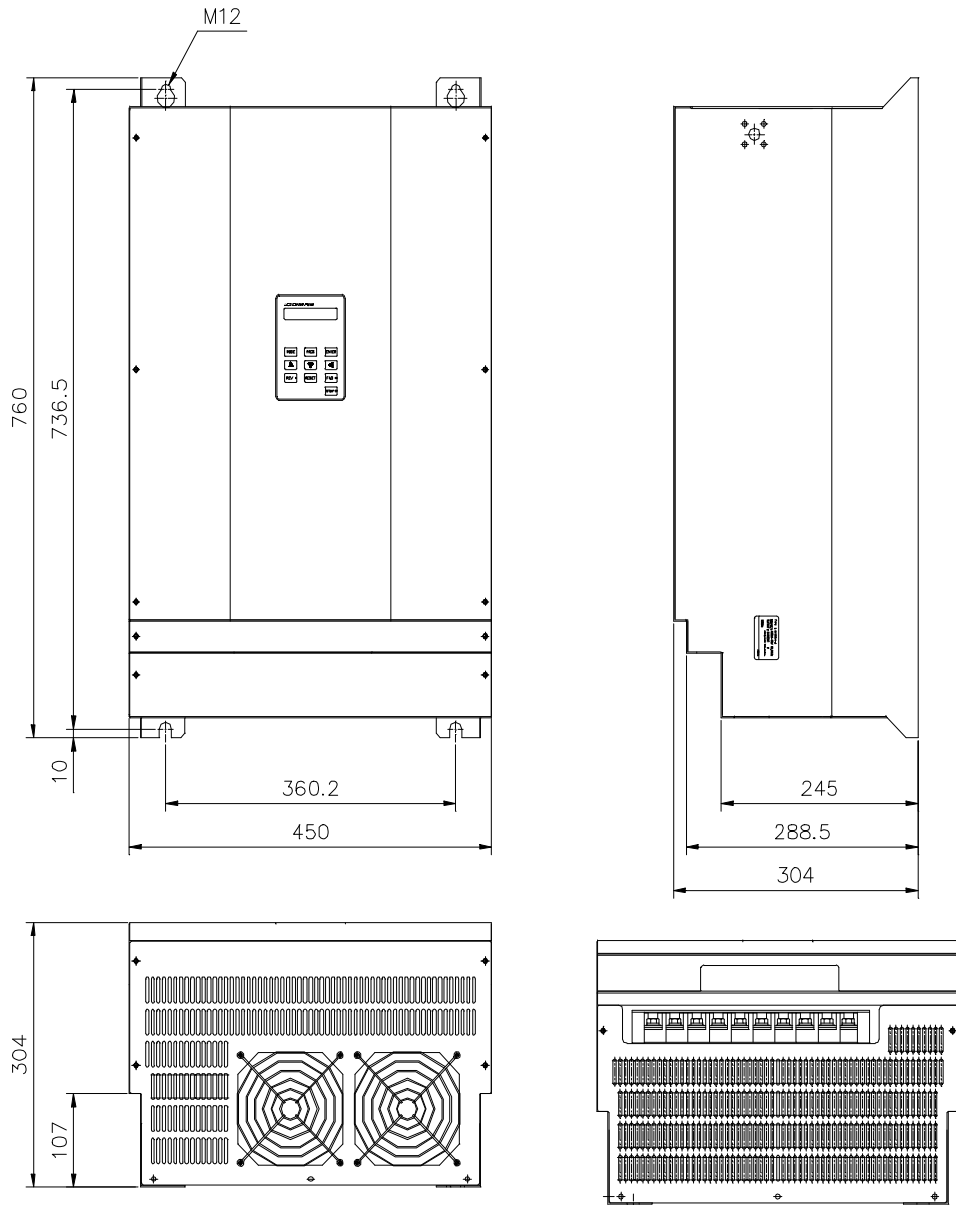

Detailed Dimensions

■ Frame #4

230VAC - 60 Hp (ACM-045H-2), 75 Hp (ACM-055H-2)

460VAC - 100 Hp (ACM-075H-4)

Unit: millimeters

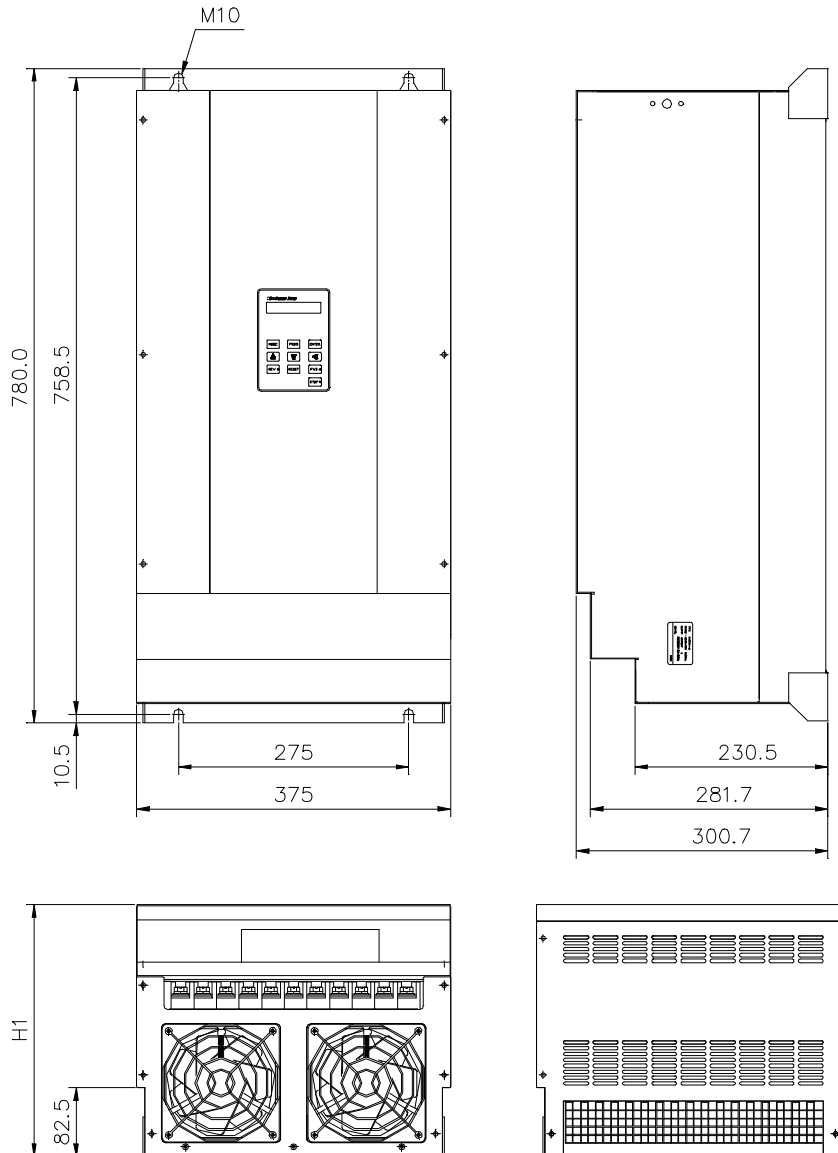

■ **Frame #5**

460VAC - 125 Hp (ACM-090H-4), 150 Hp (ACM-110H-4)

Unit: millimeters

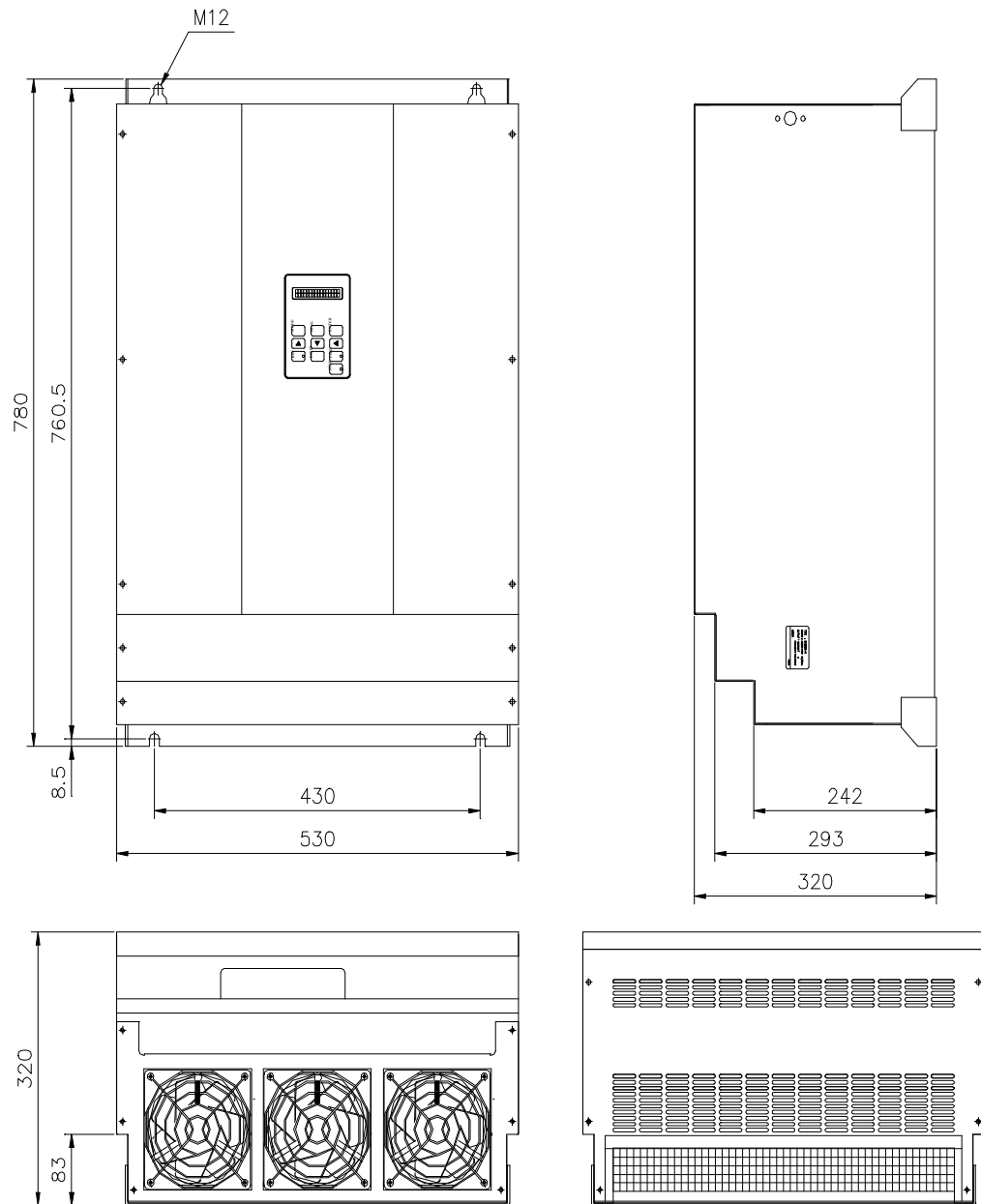

Detailed Dimensions

■ Frame #6

460VAC - 175 Hp (ACM-132H-4), 215 Hp (ACM-160H-4)

Unit: millimeters

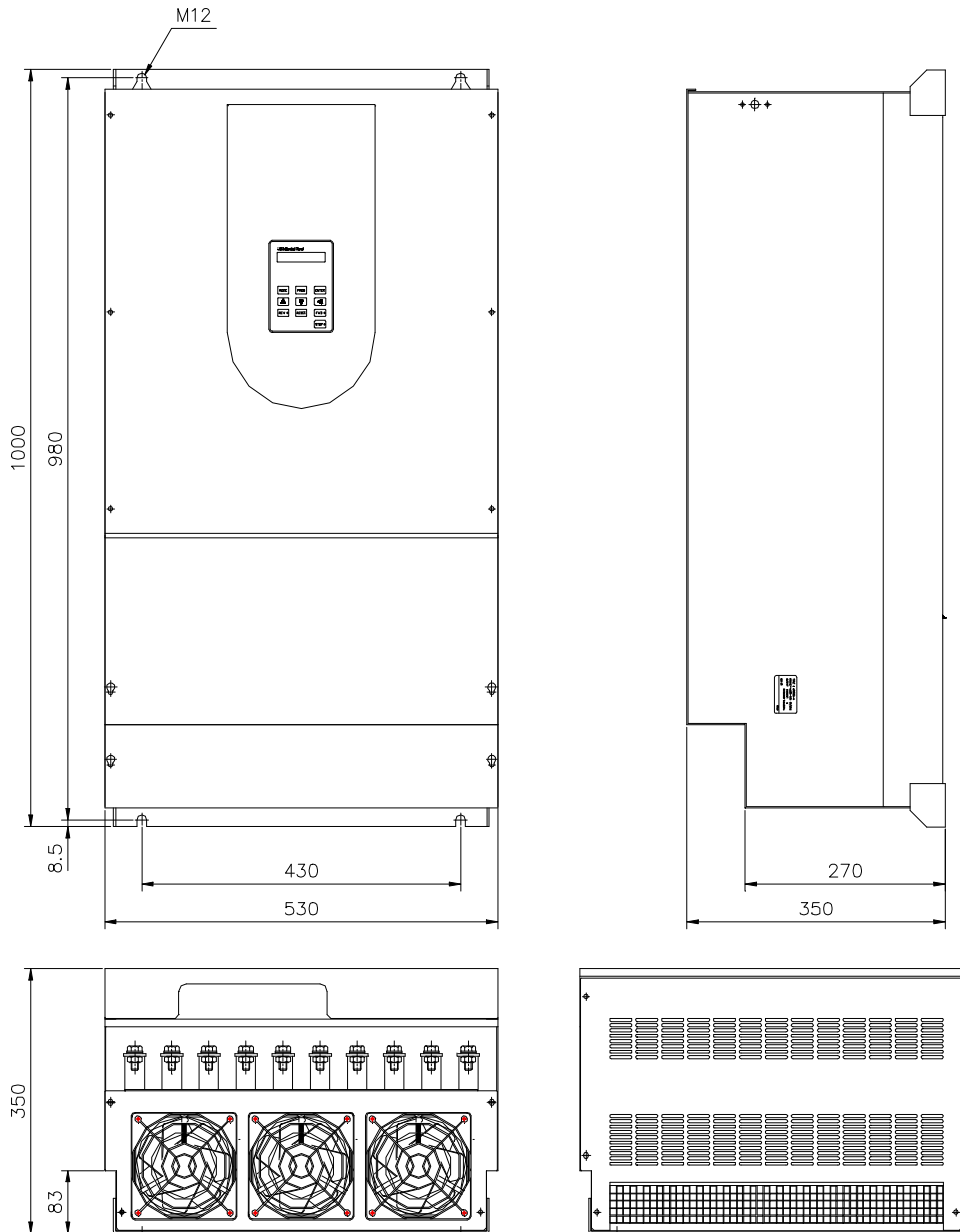

- **Frame #7**
460VAC - 300 Hp (ACM-220H-4)

Unit: millimeters

Detailed Dimensions

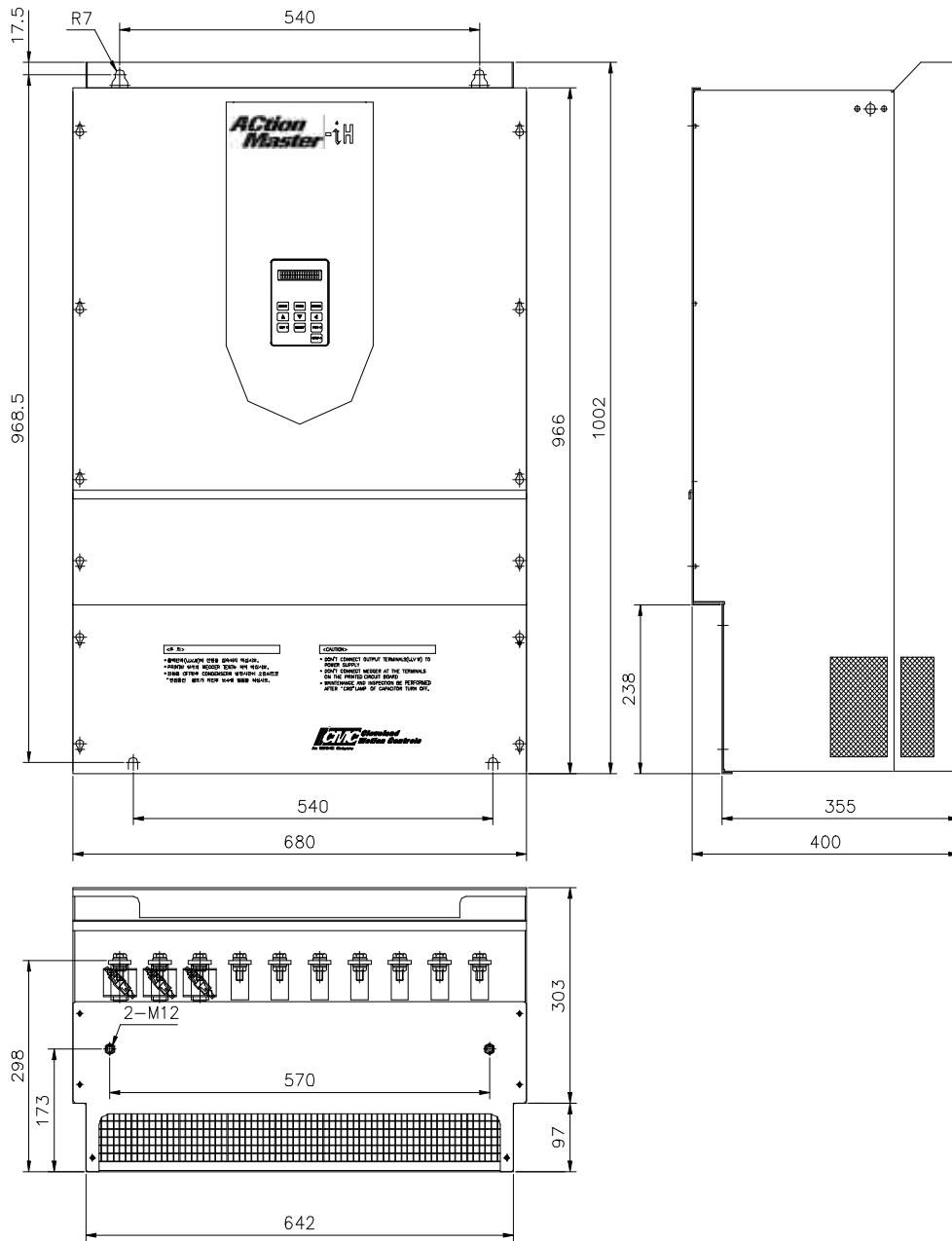



Cleveland Motion Controls

CMC constantly endeavors to improve its product so that information in this manual is subject to change without notice.

Visit Our Web site: <http://www.cmccontrols.com/>

12/21/2002