

Focus 3

Rugged and Robust

Overview

The Focus 3 is a single-phase analog drive for DC motors with power ranges from 1/4 to 5 HP. Years of proven engineering design matched with surface mount technology make this newest Focus product rugged and reliable.

Customer feedback guided the development of the Focus 3. Many features that were typically available only as options are now standard, expanding its versatility and simplifying installation.

Control Techniques' Focus 3 provides flexibility. You can stock the complete product line with the four chassis units (two regenerative and two non-regenerative) and two enclosure kits.

- Analog DC Drive
- 1/4 to 5 HP, 1 phase, 115-230 VAC
- Non-regen and Regen models
- Isolated control circuit (Regen)
- NEMA 4/12 or Chassis
- Tachometer or armature feedback
- Complete Motor Solutions



Focus Chassis



F3R2C

F3N5C

F3N2C

F3R5C

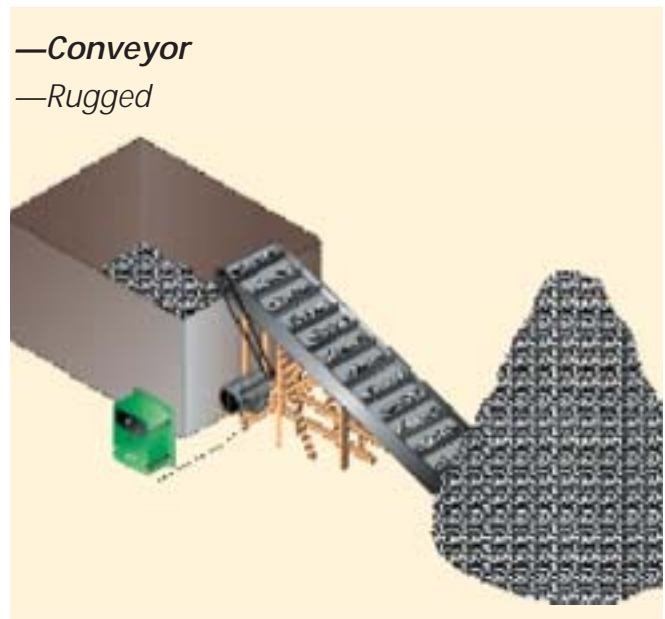

Feature

Performance Advantage

Surface mount design

Provides rugged and reliable operation at a cost-effective price

NEMA 4/12 enclosure as standard

Protects the integrity of the drive in tough, demanding environments

Regenerative and non-regenerative models available in the same footprint

Minimizes machine design variations

Jumper programmable for:

Voltage rating (115-230 VAC)

Frequency (50 / 60 Hz)

Speed or torque control

Tachometer or armature feedback

Inherent flexibility in the drive design meets numerous customer requirements with a minimal inventory of drive models and options

Independent acceleration and deceleration rates

Adaptable to many machine and process speed control requirements

Speed and current loop stability adjustments

Precisely matches the drive to the motor dynamics

Separately adjustable jog speed

Aids the customer in setting up and testing their machine

Auto (current/voltage signal) or Manual (speed pot) operation

Provides local or remote speed control without an option kit

Isolated control circuit (regen)

Signal common can be earth grounded and tied directly to other drives without additional isolation

Ratings: Focus 3

SINGLE PHASE INPUT
 .25 to 1 HP (115 VAC)
 .50 to 5 HP (230 VAC)

Non-regenerative

Motor HP	Input		Output				Model	Catalog Number
	AC Volts	Amps	DC Volts		Amps			
			Arm	Field	Arm	Field		
.25 to 1	115	14	90	100	10	1	Chassis	F3N2C
.50 to 2	230	14	180	200	10	1		
.25 to 1	115	14	90	100	10	1	NEMA 4/12	F3N2E
.50 to 2	230	14	180	200	10	1		
3 to 5	230	35	180	200	25	1	Chassis	F3N5C
3 to 5	230	35	180	200	25	1	NEMA 4/12	F3N5E

Regenerative

Motor HP	Input		Output				Model	Catalog Number
	AC Volts	Amps	DC Volts		Amps			
			Arm	Field	Arm	Field		
.25 to 1	115	16	90	100	10	1	Chassis	F3R2C
.50 to 2	230	16	180	200	10	1		
.25 to 1	115	16	90	100	10	1	NEMA 4/12	F3R2E
.50 to 2	230	16	180	200	10	1		
3 to 5	230	40	180	200	25	1	Chassis	F3R5C
3 to 5	230	40	180	200	25	1	NEMA 4/12	F3R5E

Focus 3 is available with factory installed modifications. To order choose the drive required from the table below and then add modification suffixes to the catalog number (separated by hyphens).

Order String

F3 X X X- XX - XX

Modification 2, etc.

Modification 1

C = Chassis, E = Enclosed

Drive Horsepower: 2 = 2 HP, 5 = 5 HP

N = Non-regen, R = Regen

F3 = Focus 3 Product Family

Terminal Diagram: Focus 3

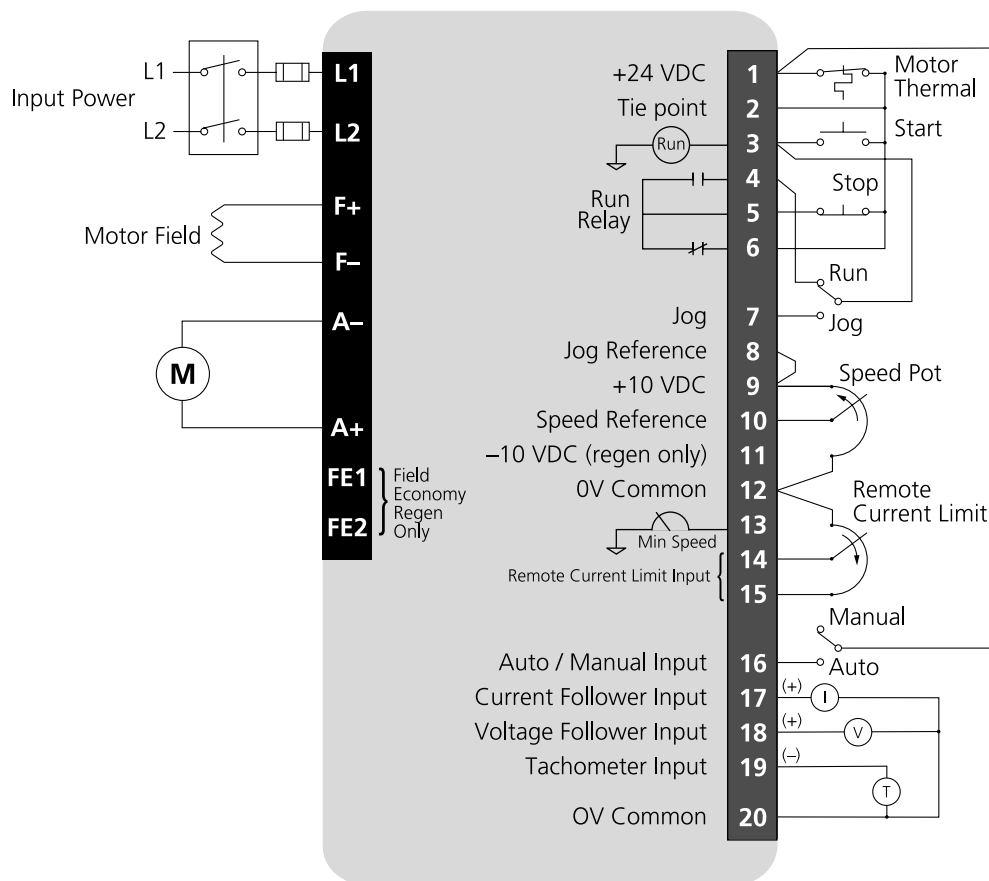

Terminal Description

Pin #	Type	Notes
1	+24 VDC Power Supply	For drive use only
2	Tie Point (motor thermal)	No internal connection
3	Run Relay	+24 VDC @ 10 mA
4	Relay (N.O.)	Run relay contact
5	Relay Common	120 VAC, @ 1A resistive
6	Relay (N.C.)	
7	Jog Reference Select (Logic Input)	+24 VDC, 30k Ohms (requires run input)
8	Jog Pot Supply Input	Analog Input, ± 10 VDC (-10 VDC regen only)
9	+10 VDC	Reference Supply, 5 mA max
10	Speed Reference	Analog Input, ± 10 VDC, 20k Ohms
11	-10 VDC (regen only)	Reference Supply, 5 mA max
12	Circuit Common	Circuit common hot to earth ground (non-regen only)
13	Minimum Speed Pot	For use with speed pot only
14	Remote Current Limit Pot Input	Wiper input (refer to Jumpers JP6 & JP7)
15	Remote Current Limit Pot Input	CW connection (refer to Jumpers JP6 & JP7)
16	Auto / Manual Input	Logic Input, +24 VDC @ 30k Ohms
17	Current follower Input	Analog Input, 4-20 or 1-5 mA
18	Voltage follower Input	Analog Input, 200 VDC max
19	DC tachometer Input (-)	Analog Input, 160 VDC max
20	DC tachometer Input (+)	Circuit common

Specifications: Focus 3

	Adjustments
Maximum Speed	80 to 120% of rated speed
Minimum Speed	0 to 30% of maximum speed
IR Compensation	0 to 20% of rated voltage
Current Limit	0 to 150% of selected range
Acceleration	0.3 to 20 seconds
Deceleration	0.3 to 20 seconds
Jog Speed	0 to 30% of rated speed
	Operator Functions
Speed Adjustment	Standard
Start/Stop	Standard (<i>Enclosed</i>) Customer Supplied (<i>Chassis</i>)
Run/Jog	Option Kit
Forward/Reverse (Regen Only)	Option Kit
Auto/Manual	Option Kit
	Customer Selectable
Rated Input Voltage	115 or 230 VAC
Control Mode	Speed or Torque
Output Current	Hi / Med / Low / Xlow
Armature Voltage Feedback	Hi (180) / Lo (90) VDC
Tachometer Feedback	Hi / Lo
Speed Feedback Selector	Armature / Tachometer
Line Frequency	50 / 60 Hz
Current Limit Pot Selector	Local / Remote
	Control
Logic Control Power	24 VDC
Speed Potentiometer	5k Ohms, 2 watts
Speed Regulation (95% load change):	
Armature Voltage Feedback	1% of maximum speed with IR compensation. (does not include drift due to field)
Tachometer Feedback (i.e. 5PY)	0.5% of base speed
	Drive Operating Conditions
NEMA 4/12 Enclosure	Standard (<i>Enclosed</i>) Option Kit (<i>Chassis</i>)
Altitude	1000m (3,300 ft)
Ambient Temperature	0 to 40°C (32 to 104°F) (<i>Enclosed</i>) 0 to 55°C (32 to 131°F) (<i>Chassis</i>)
Rated Input Voltage	115-230 VAC ±10%
Rated Frequency	48 to 62 Hz
Overload Capacity	150% of selected rating
Efficiency:	
Controller (min)	98%
Drive (typical)	86%

Dimensions

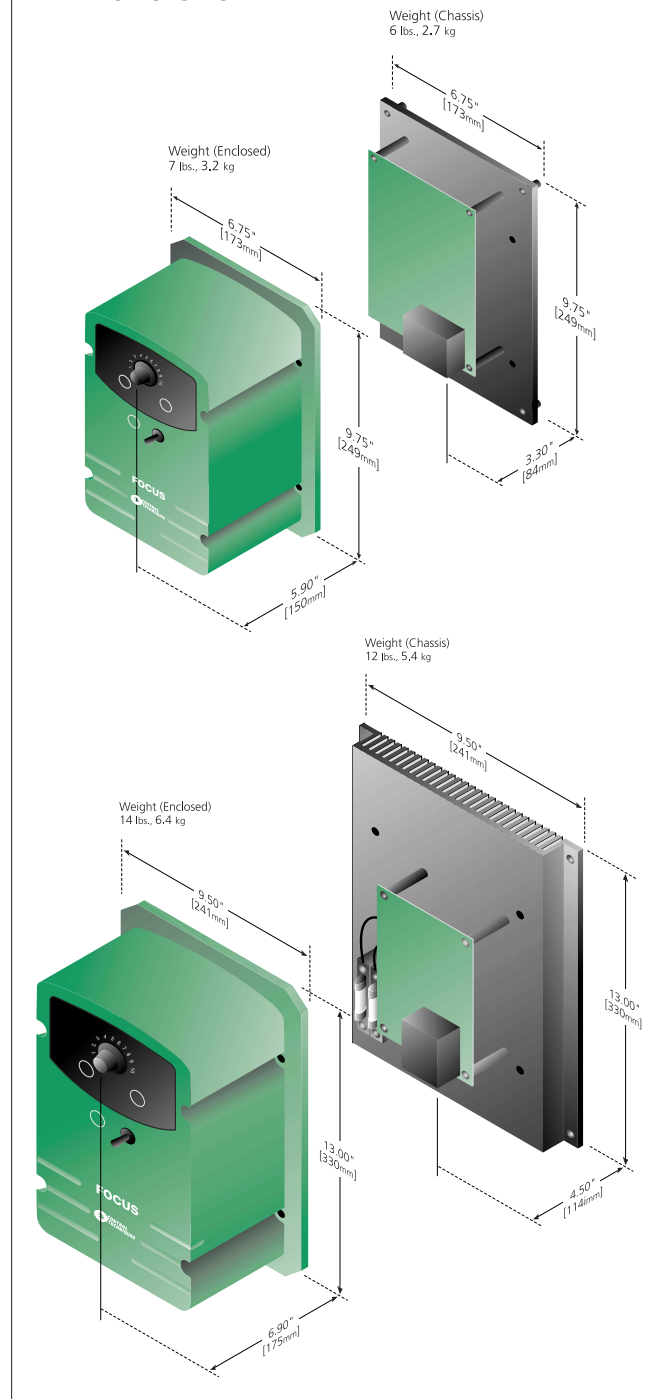

Focus 3 Options

Factory Installed Modifications

Focus 3 Kits are available as either factory-installed options or field kits. To order factory installed modifications, choose the basic drive required from the ratings table on page 91 and then add modification suffixes (separated by hyphens) to the basic catalog number.

Function	Description	Suffix
"M" Contactor Kits*	.25 - 1 HP @ 115V	M1
	.50 - 2 HP @ 230V	M2
	3 - 5 HP @ 230V	M5
Dynamic Braking Kits	.5 HP @ 115 V, 2 HP @ 230V	DB2
	.25 - .33 HP @ 120V, 1.5 HP @ 230V	DB4
	.75 - 1 HP @ 230V	DB6
	.5 HP @ 230V	DB7
	.75 - 1 HP @ 115V	DB1
	3 HP @ 230V	DB3
	5 HP @ 230V	DB5
Toggle Switches	Run / Jog	TSA
	Auto / Manual	TSB
	Forward / Reverse	TSC
Signal Isolation	Signal Isolation Board	NS
Feedback	AC Tachometer Input Board	ACT
Speed Pot	Ten-Turn Potentiometer	TTP

* When the "M" kit is factory installed, UL will not apply.

Enclosure Option

By stocking these two enclosure kits along with the four chassis drives, the distributor can supply all Focus 3 models. The enclosure kits include the speed pot and the start / stop switch pre-wired to a plug-on terminal strip and all gasketing required for a NEMA 4/12 rating.



2 HP, non-regen and regen.....F3SE

5 HP, non-regen and regen.....F3LE

Toggle Switch (F3TS)

This kit is used to provide one of the following functions: Run / Jog, Auto / Manual or Fwd / Rev (regen only). It can be mounted in the Focus 1 or Focus 3 enclosure cover, remote operator station (0895-8000), or remotely mounted when used with the chassis drive. The F3TS kit includes the toggle switch, NEMA 4/12 switch boot and connection wires for enclosure cover use. A maximum of three kits may be used with the enclosure cover.

"M" Contactor Kit

This kit provides a positive disconnect of the motor armature when the controller is stopped, preventing motor rotation in the event of SCR misfire due to line noise. It includes the DB (dynamic braking) poles, an auxiliary normally open (N.O.) contact, all connection wires and a magnetic contactor for mounting in the Focus 3 chassis or enclosed drives. This kit may be required by local and / or national electrical codes.

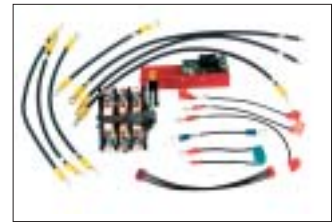
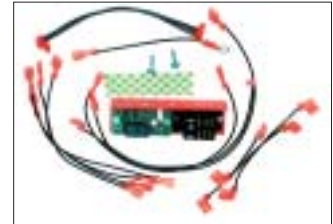

- 1 HP, 115 VAC..... F3M112
- 2 HP, 230 VAC..... F3M224
- 5 HP, 230 VAC..... F3M524

Dynamic Braking Kit

Dynamic braking provides rapid motor stopping by quickly dissipating the stored energy in the rotating motor and load. These kits are designed for use with the Focus 3 contactor kits. The resistors have been sized in accordance with the following NEMA specification for dynamic braking: *"Three stops in rapid succession with the load inertia equal to the motor inertia then cooling forever."*

AC Input	HP (Typical)	DB Kit Catalog Number
120 VAC	.25 to .33	F3DB1524
	.5	F3DB224
	.75 to 1	F3DB112
240 VAC	.5	F3DB0524
	.75 to 1	F3DB224
	1.5	F3DB1524
	2	F3DB224
	3	F3DB324
	5	F3DB524



Focus 3

AC Tachometer Input Board (F3ACT)

This option kit allows the Focus 3 to accept AC tachometer feedback. It mounts directly to the Focus 3 control board and accepts a range of 45 to 110 VAC at maximum speed.



Signal Isolator Board (F3NSBD)

This option is used in applications where isolation is required between an external control signal and the motor controller (which may or may not be at earth ground

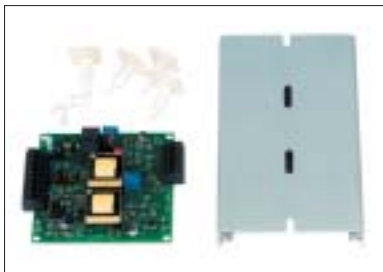

potential). It can be used to isolate a variety of voltage or current signals (see specifications below) or simply to isolate the speed potentiometer. The potentiometer power supply is included. This option can be mounted inside the Focus 3 cover or panel mounted on a piece of curts track (included with kit). Because the board has a uni-polar output, it is typically used on single directional applications.

Specifications

Input Power	17 to 30 VDC @ 50 mA max. (for control circuitry)
Control Relay	24 VDC @ 12.1 mA (JP5 = 24 VDC) 115 VAC @ 20 mA (JP5 = 120 VAC)
Relay Contacts	(qty. 2) Form A, 1A @ 250 VAC
Isolation Voltage	240 VAC line voltage 2000 VAC hi-pot for 1 minute
Voltage Ranges	5, 12, 26, 52, 98 & 208 VDC 180 Ohms/volt
Current Ranges	0 - 5 or 1- 5 mA 910 Ohms input impedance 0 - 20 or 4 - 20 mA 250 Ohms input impedance
Speed Pot	5k Ohms, 2 watts (includes +10 VDC power supply for the pot)
Output	0 to +10 VDC (uni-polar)

Remote Percent / RPM Speed Meters

These meters are used for remote display of the motor speed in RPM (up to 2000 rpm) or percent of maximum speed. Included is a universal calibration board. The 4.5" meter is enclosed in a NEMA 1 steel enclosure suitable for panel or wall mounting.



Percent Speed Meter2450-9024

RPM Speed Meter2450-9021

Ten-turn Speed Potentiometer (6160-9001)

This ten-turn speed pot provides a vernier scale for precise and repeatable speed setting while a locking tab prevents inadvertent speed changes. It may be



mounted in the Focus 1 or Focus 3 enclosure, or in a remote operator station as described above (OPS4N01-PORS) or supplied by the customer.